

2004 ACCESSORIES & EQUIPMENT

Doors - Hummer H2

SPECIFICATIONS

FASTENER TIGHTENING SPECIFICATIONS

Fastener Tightening Specifications

Application	Specification	
	Metric	English
Door Check Link Bolts	9 N.m	7 ft lb
Door Check Link Nuts	9 N.m	7 ft lb
Door Handle Nuts	9 N.m	7 ft lb
Door Hinge Bolts	25 N.m	73 ft lb
Lock Actuator Bolts - Door	9 N.m	7 ft lb
Lock Striker Bolts	27 N.m	20 ft lb
Outside Mirror Bolts	25 N.m	19 ft lb
Window Clamp Bolts	9 N.m	7 ft lb
Window Regulator Bolts	9 N.m	7 ft lb
Window Run Channel Bolts	9 N.m	7 ft lb
Window Stabilizer Bolts	9 N.m	7 ft lb

SCHEMATIC AND ROUTING DIAGRAMS

POWER WINDOW SCHEMATICS

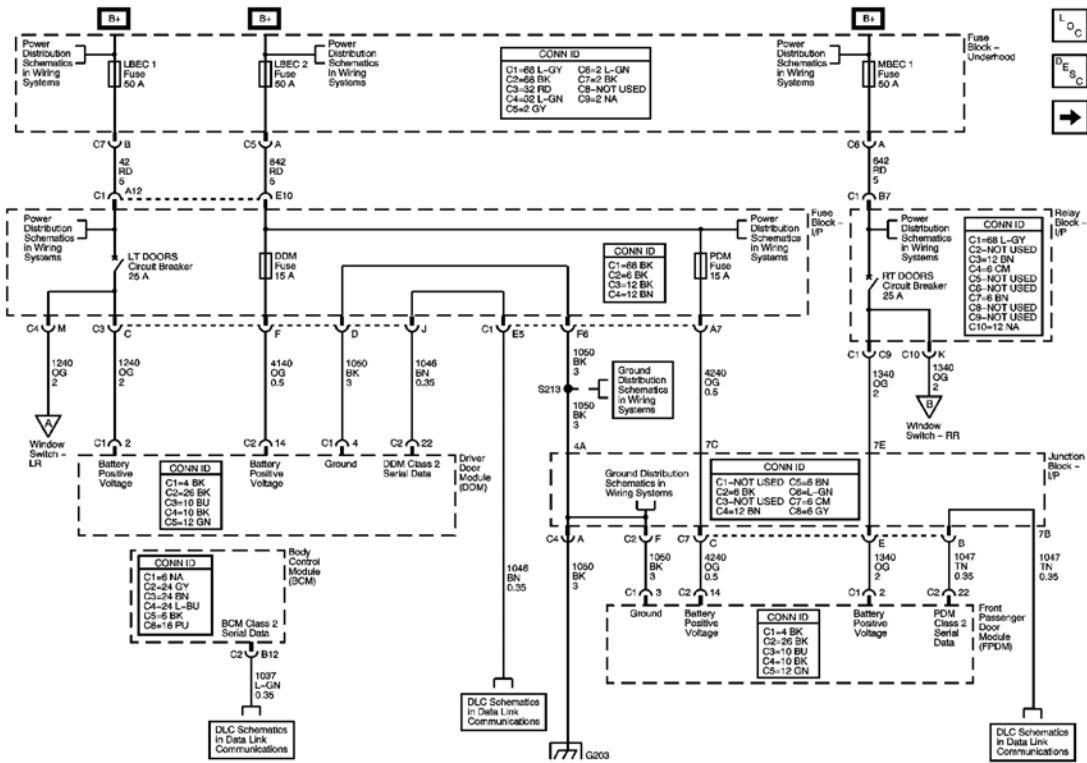

Fig. 1: Door Modules - Power, Grounding, and DLC
 Courtesy of GENERAL MOTORS CORP.

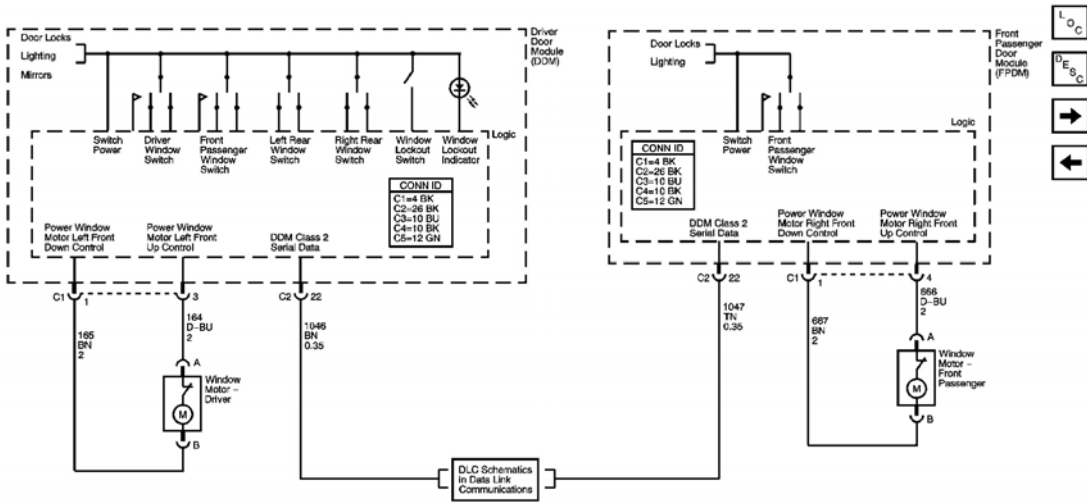

Fig. 2: Front Door Windows
 Courtesy of GENERAL MOTORS CORP.

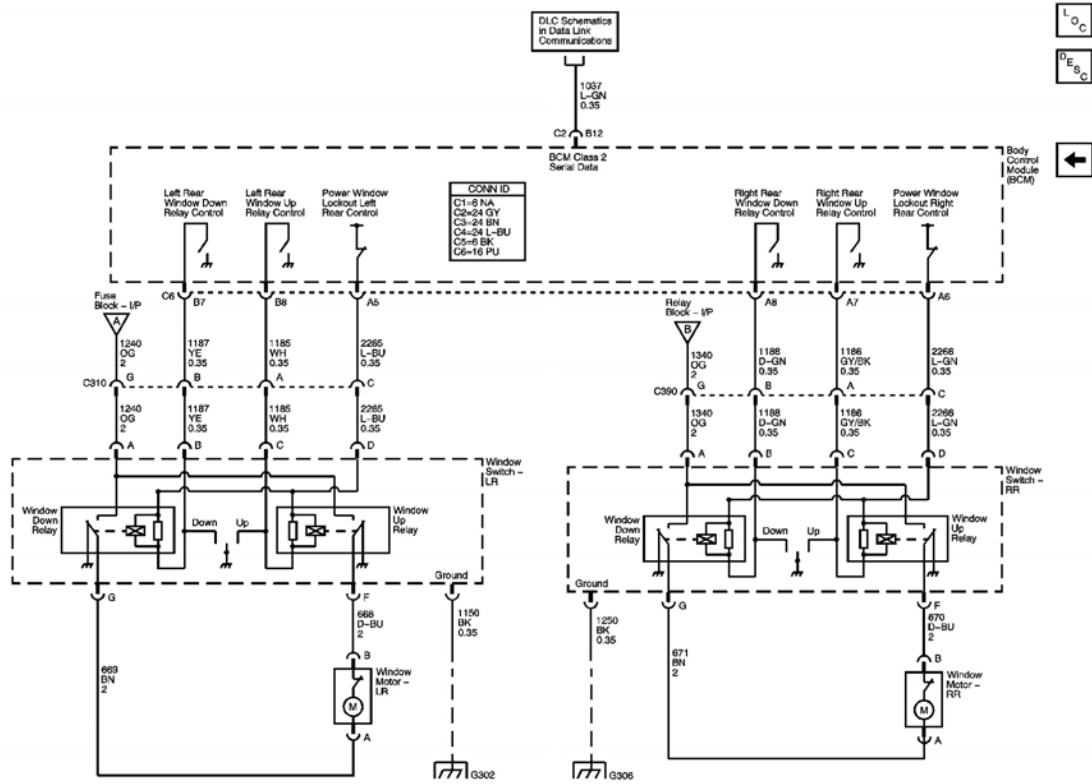

Fig. 3: Rear Door Windows
 Courtesy of GENERAL MOTORS CORP.

DOOR LOCK/INDICATOR SCHEMATICS

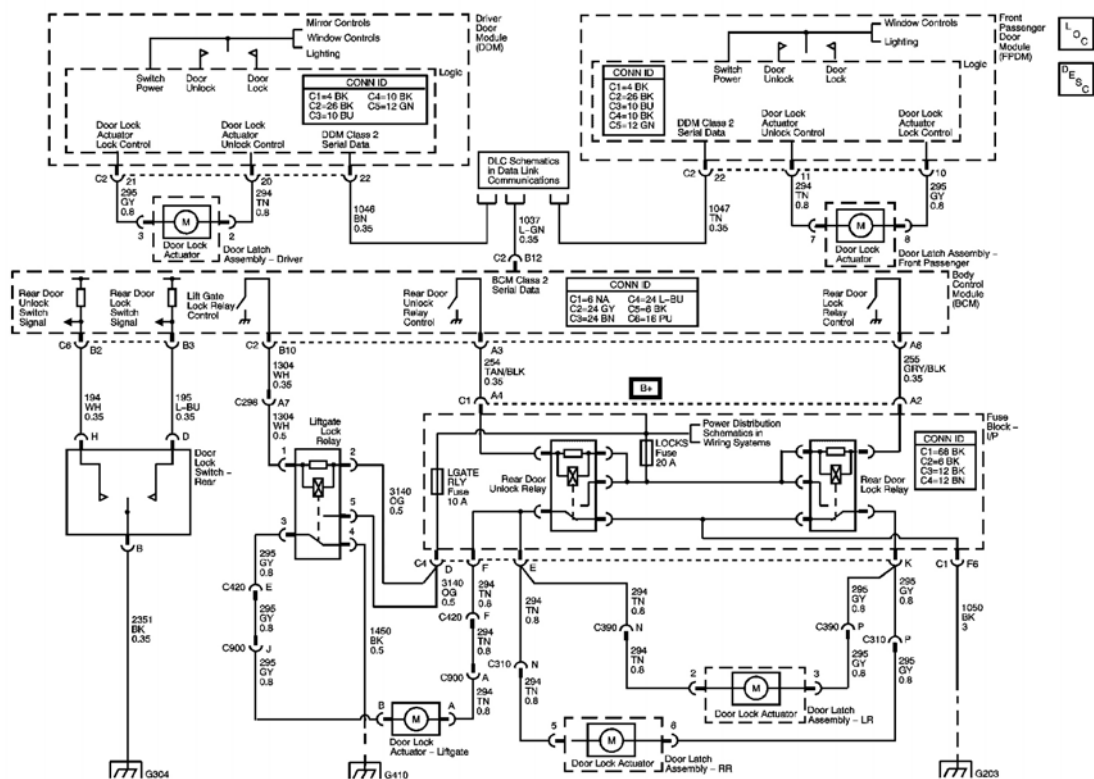

Fig. 4: Door/Lock Indicator
 Courtesy of GENERAL MOTORS CORP.

OUTSIDE MIRROR SCHEMATICS

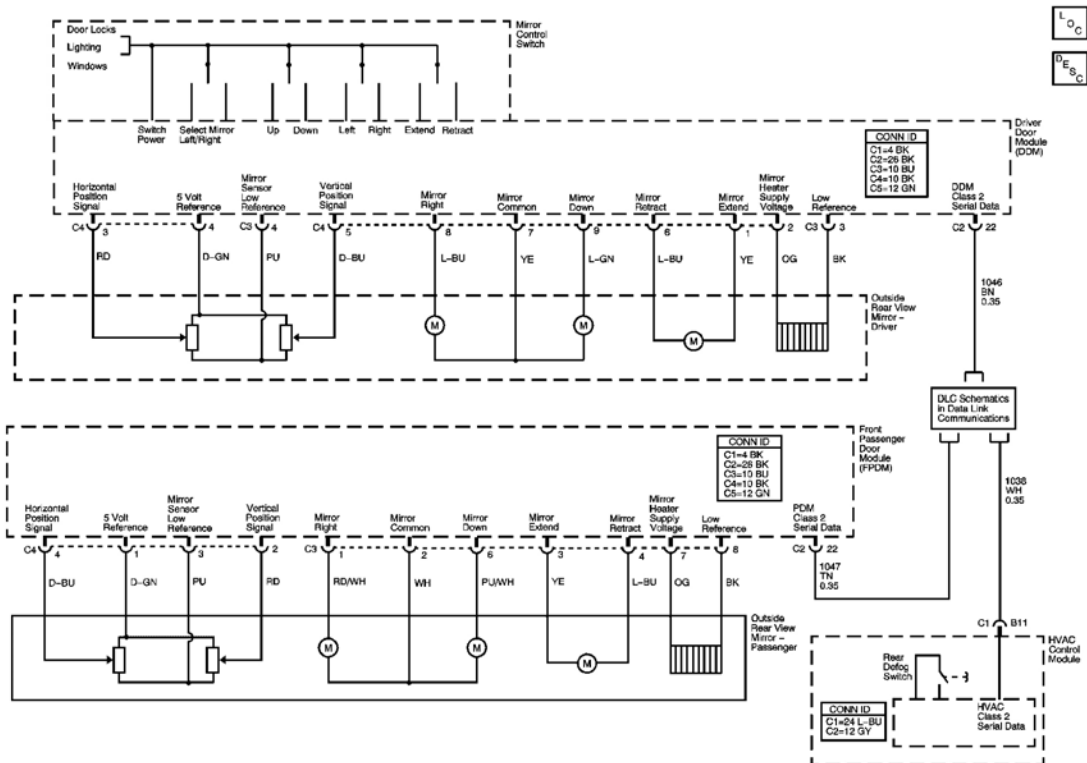

Fig. 5: Outside Mirror
 Courtesy of GENERAL MOTORS CORP.

COMPONENT LOCATOR

POWER DOOR SYSTEMS COMPONENT VIEWS

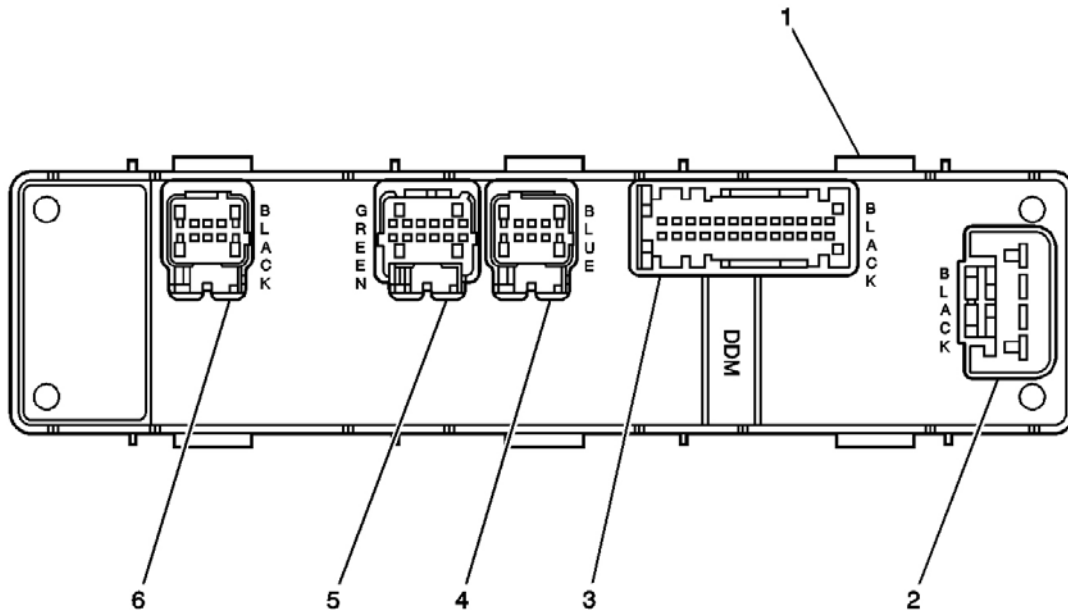

Fig. 6: Driver Door Module (DDM) Connector Locations Component Views
 Courtesy of GENERAL MOTORS CORP.

Callouts For Fig. 6

Callout	Component Name
1	DDM
2	DDM - C1 (Black)
3	DDM - C2 (Black)
4	Mirror Harness Connector - C3 (Blue)
5	Memory/Heated Seat Switch Connector - C5 (Green)
6	Mirror Harness Connector - C4 (Black)

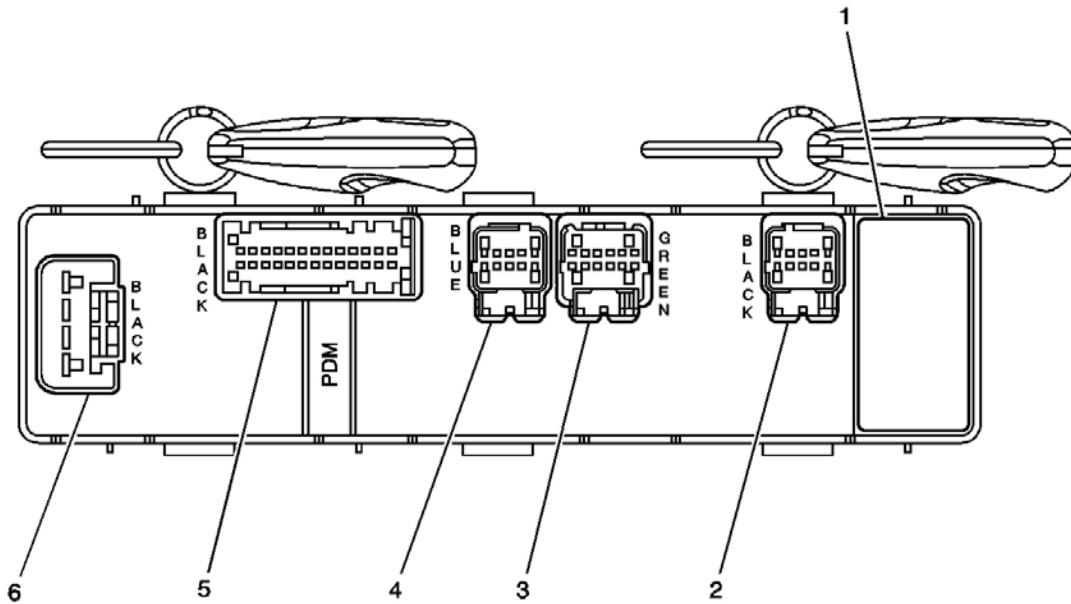

Fig. 7: Front Passenger Door Module (FPDM) Connector Locations Component Views
 Courtesy of GENERAL MOTORS CORP.

Callouts For Fig. 7

Callout	Component Name
1	FPDM
2	Mirror Harness Connector - C4 (Black)
3	Memory/Heated Seat Switch Connector - C5 (Green)
4	Mirror Harness Connector - C3 (Blue)
5	FPDM - C2 (Black)
6	FPDM - C1 (Black)

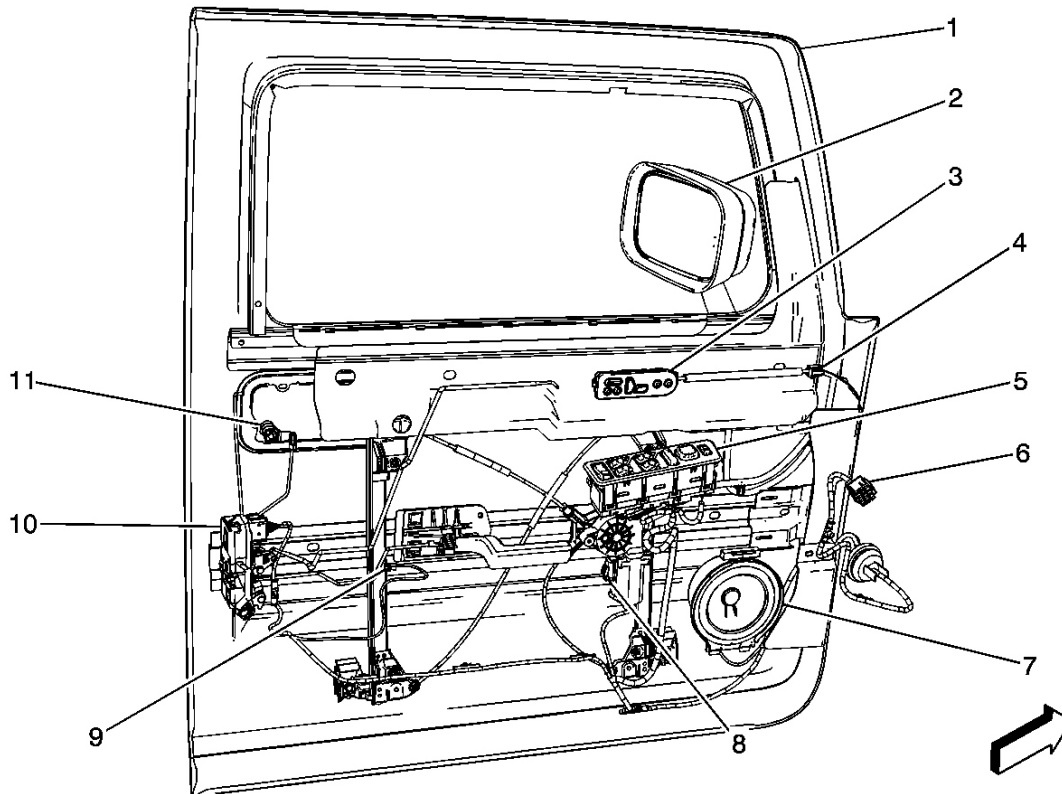

Fig. 8: Driver Door Component Views
 Courtesy of GENERAL MOTORS CORP.

Callouts For Fig. 8

Callout	Component Name
1	Driver Door
2	Outside Rearview Mirror
3	Memory/Heated Seat Switch
4	Memory/Heated Seat Switch Connector - C5 (Green)
5	Driver Door Module (DDM)
6	Fuse Block - I/P - C3
7	Speaker - LF Door
8	Window Motor - Driver
9	Courtesy Lamp - Left Door
10	Door Latch Assembly - Driver
11	Door Latch Assembly Connector - Driver

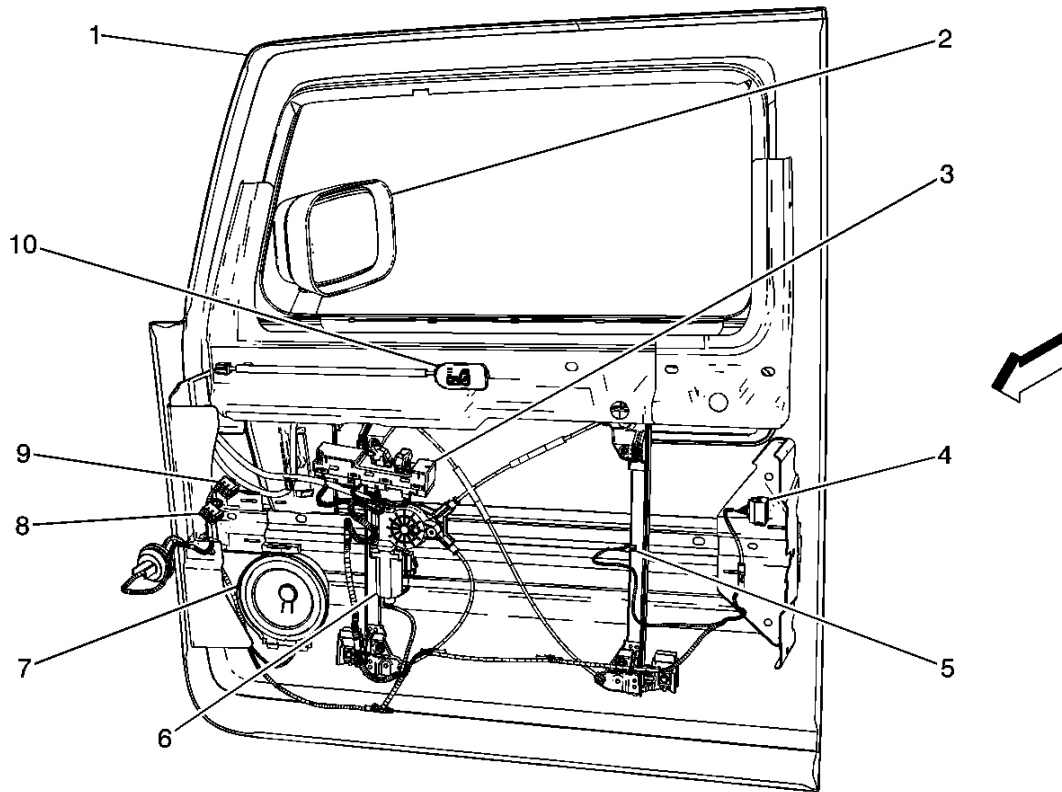
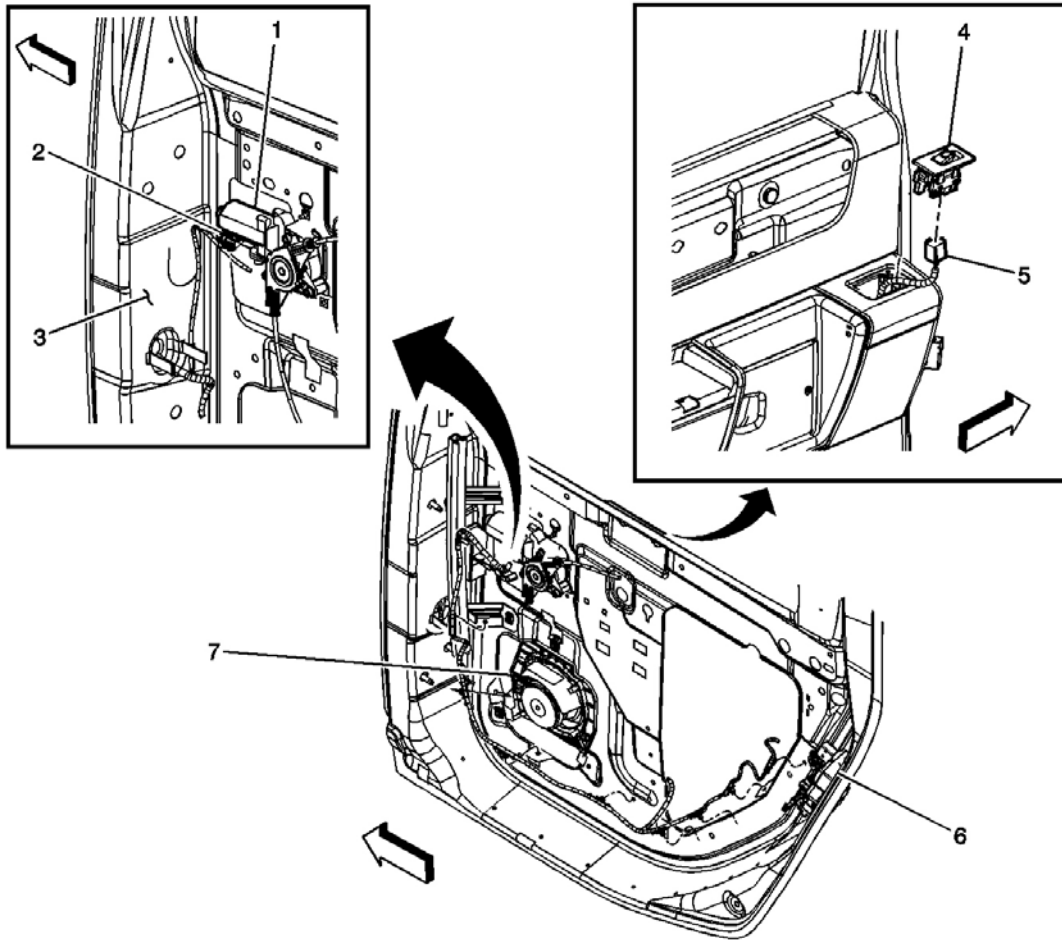

Fig. 9: Passenger Door Component Views
 Courtesy of GENERAL MOTORS CORP.

Callouts For Fig. 9

Callout	Component Name
1	Passenger Door
2	Outside Rearview Mirror
3	Passenger Door Module (PDM)
4	Door Latch Assembly - Passenger
5	Courtesy Lamp - Right Door
6	Window Motor - Front Passenger
7	Speaker - RF Door
8	Junction Block - I/P - C2
9	Junction Block - I/P - C7
10	Heated Seat Switch



**Fig. 10: Left Rear Door Component Views (RT Rear Door Similar)
Courtesy of GENERAL MOTORS CORP.**

Callouts For Fig. 10

Callout	Component Name
1	Door Window Motor - LR
2	Door Window Motor Connector - LR
3	Door Harness Pass-Through Grommet
4	Door Window Switch - LR
5	Door Window Switch Connector - LR
6	Door Latch Assembly - LR
7	Speaker - LR Door

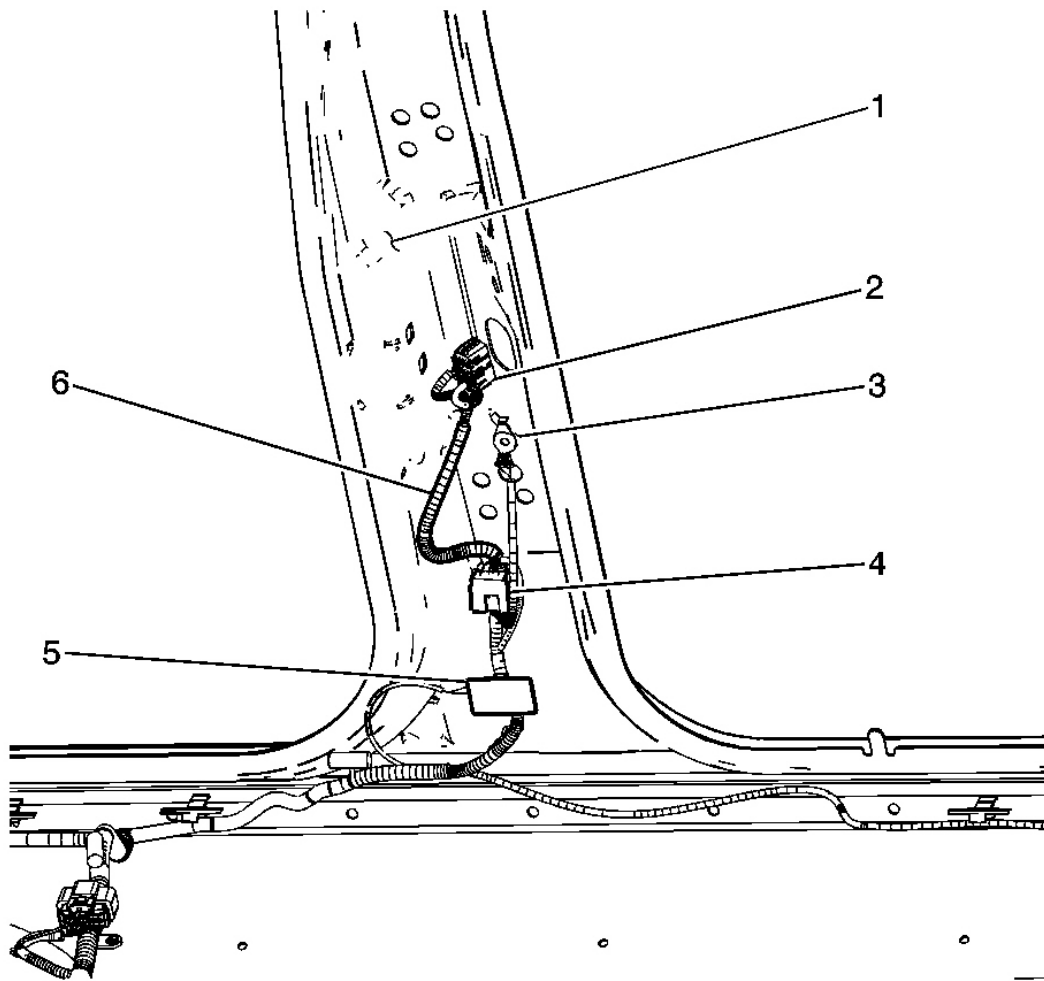

Fig. 11: Liftgate Relay Component Views
 Courtesy of GENERAL MOTORS CORP.

Callouts For Fig. 11

Callout	Component Name
1	Right B-Pillar
2	C390
3	G306
4	Liftgate Lock Relay
5	Courtesy Lamp - Right B-Pillar
6	Body Harness

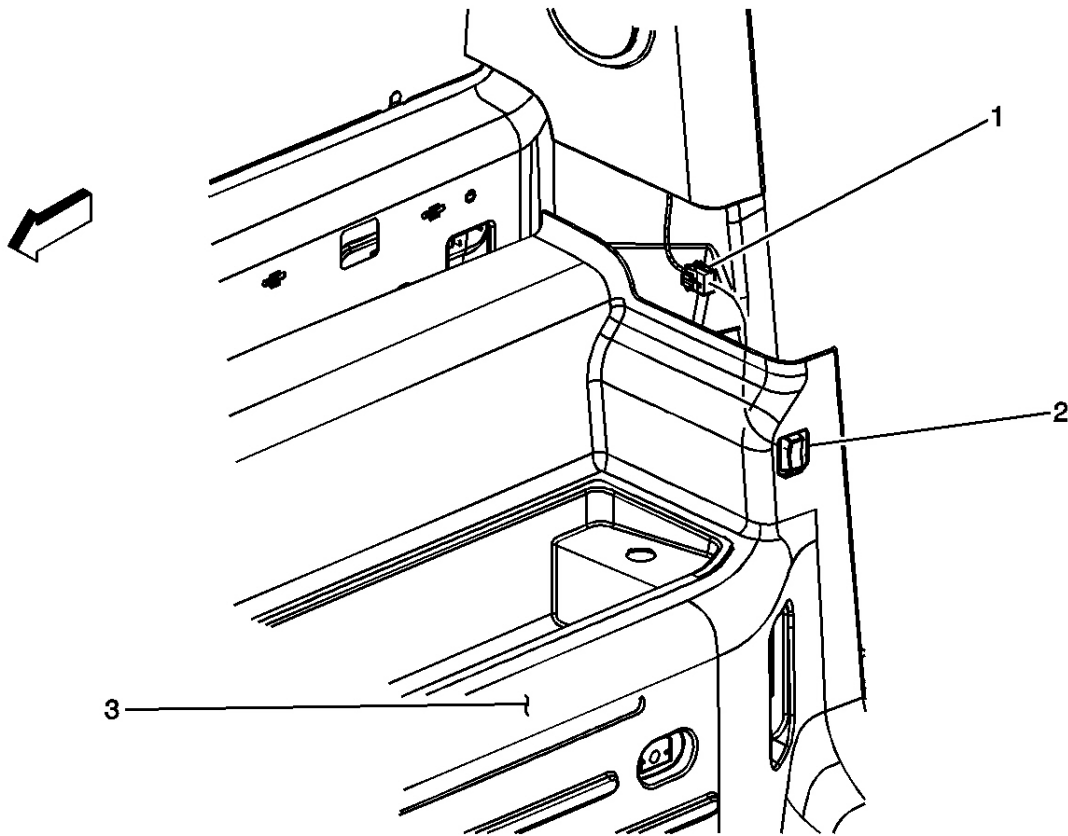

Fig. 12: Door Lock Switch-Rear Cargo Area Component Views
 Courtesy of GENERAL MOTORS CORP.

Callouts For Fig. 12

Callout	Component Name
1	Door Lock Switch Connector - Rear
2	Door Lock Switch - Rear
3	Rear Storage Bin

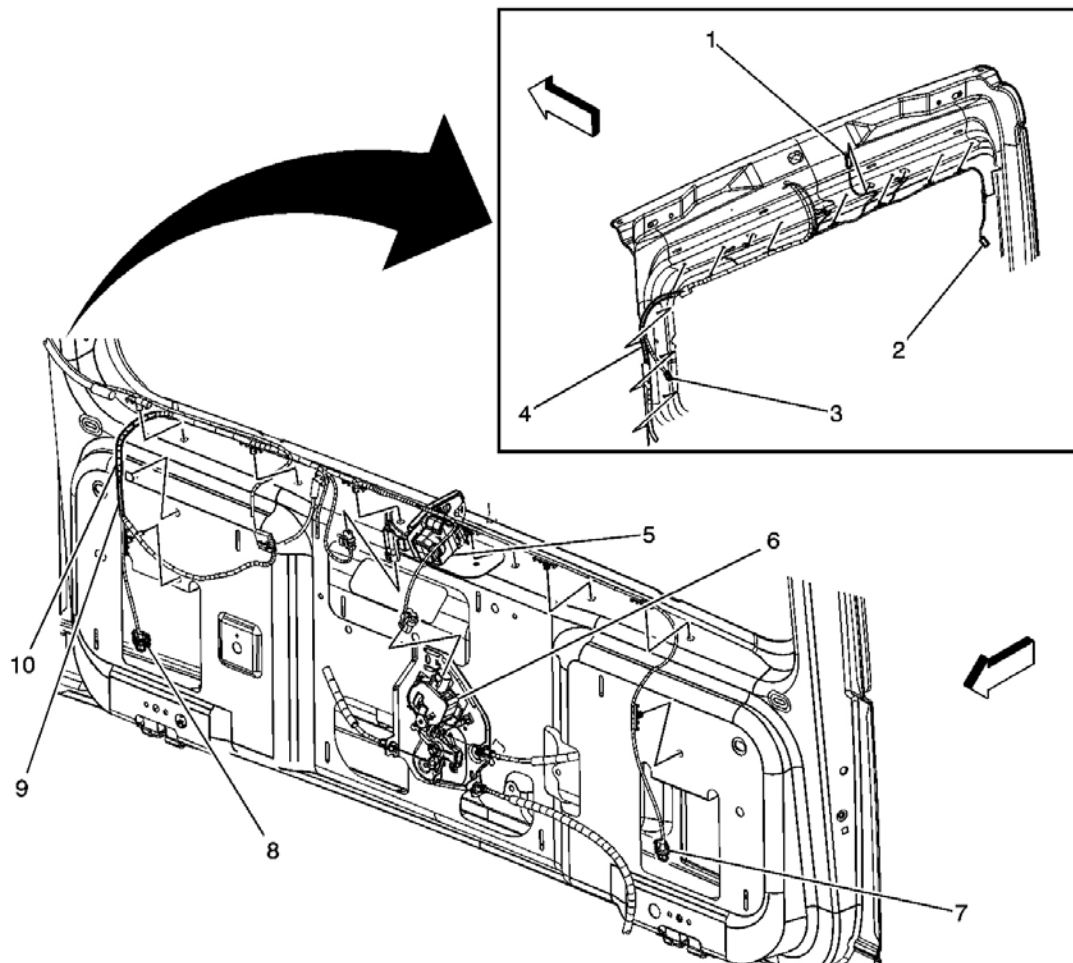

Fig. 13: Door Lock Actuator - Liftgate Component Views
 Courtesy of GENERAL MOTORS CORP.

Callouts For Fig. 13

Callout	Component Name
1	Center High Mounted Stop Lamp (CHMSL) Connector
2	Rear Window Defogger Grid Connector
3	Rear Window Defogger Grid Connector
4	Splice S900
5	Rear Window Wiper Module - w/Motor
6	Door Lock Actuator - Liftgate
7	Liftgate Ajar Switch - Left
8	Liftgate Ajar Switch - Right
9	Splice S902
10	Splice S901

POWER DOOR SYSTEMS CONNECTOR END VIEWS

Door Latch Assembly Terminal Identification - Driver

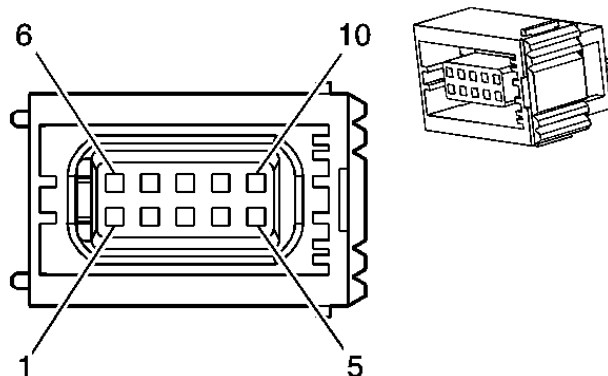

Connector Part Information		<ul style="list-style-type: none">• 10768367• 10-Way F SLD AMP (BK)	
Pin	Wire Color	Circuit No.	Function
1	-	-	Not Used
2	TN	294	Door Lock Actuator Unlock Control
3	GY	295	Door Lock Actuator Lock Control
4-5	-	-	Not Used
6	GY/BK	745	Left Front Door Ajar Switch Signal
7	-	-	Not Used
8	BN	1183	Left Front Door Switch Low Reference
9	L-GN	262	Driver Door Key Switch Signal
10	-	-	Not Used

Door Latch Assembly Terminal Identification - Front Passenger

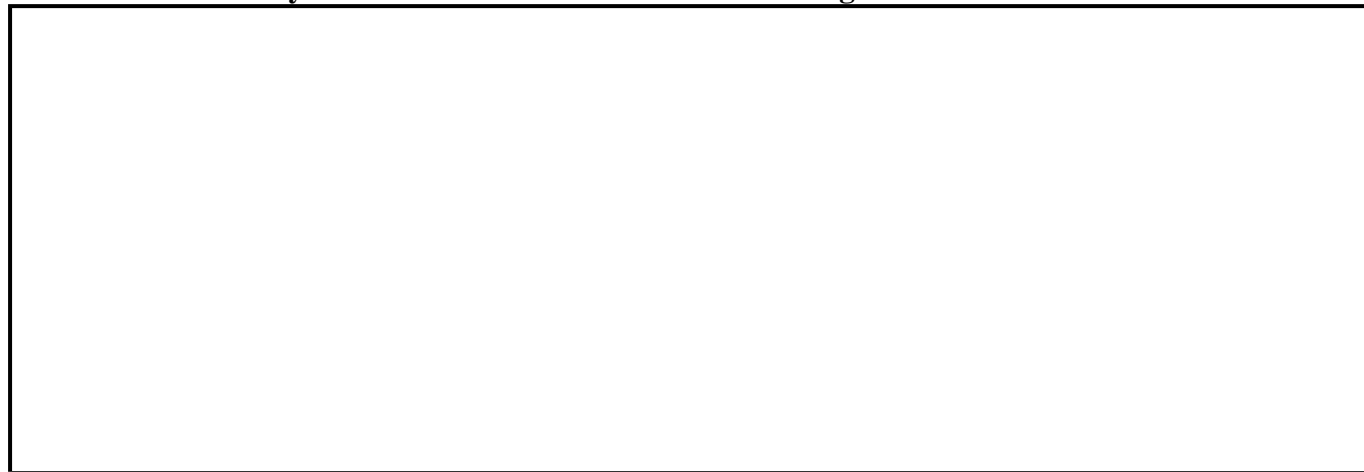

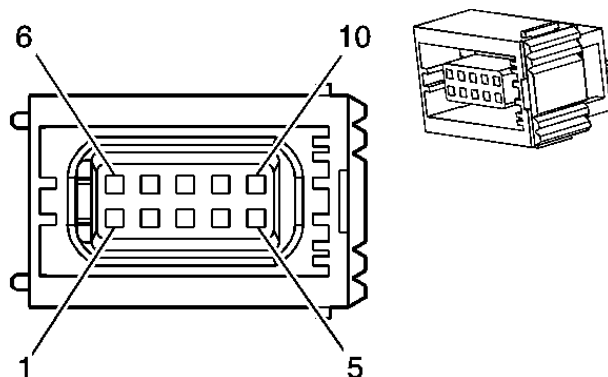

Connector Part Information

- 10768367
- 10-Way F AMP SLD (BK)

Pin	Wire Color	Circuit No.	Function
1	BK/WH	746	Right Front Door Ajar Switch Signal
2	-	-	Not Used
3	D-GN	1178	Right Front Door Switch Low Reference
4	L-GN	265	Passenger Door Key Switch Signal
5-6	-	-	Not Used
7	TN	294	Door Lock Actuator Unlock Control
8	GY	295	Door Lock Actuator Lock Control
9-10	-	-	Not Used

Door Latch Assembly Terminal Identification - LR

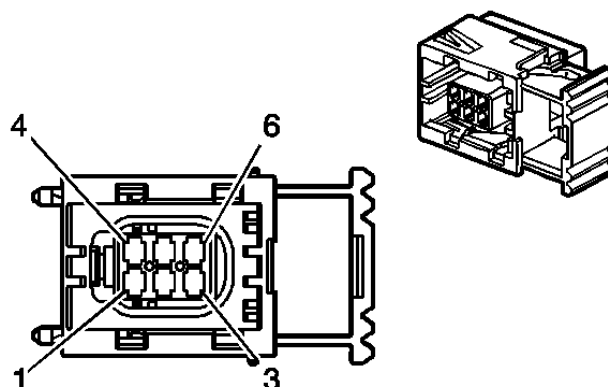

Connector Part Information

- 10768369

• 6-Way F SLD AMP (BK)			
Pin	Wire Color	Circuit No.	Function
1	-	-	Not Used
2	TN	294	Door Lock Actuator Unlock Control
3	GY	295	Door Lock Actuator Lock Control
4	L-BU/BK	747	Left Rear Door Ajar Switch Signal
5	-	-	Not Used
6	BK	1150	Ground

Door Latch Assembly Terminal Identification - RR

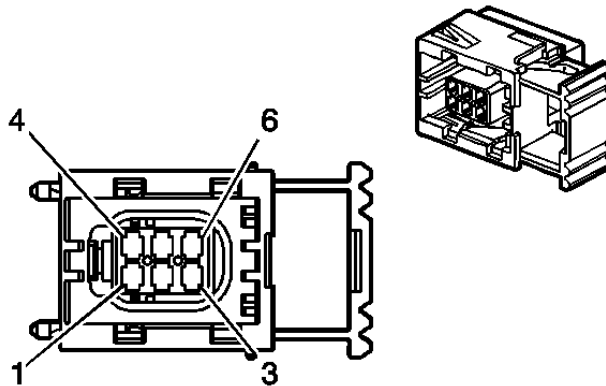

Connector Part Information		• 10768369 • 6-Way F SLD AMP (BK)	
Pin	Wire Color	Circuit No.	Function
1	L-GN/BK	748	Right Rear Door Ajar Switch Signal
2	-	-	Not Used
3	BK	1250	Ground
4	-	-	Not Used
5	TN	294	Door Lock Actuator Unlock Control
6	GY	295	Door Lock Actuator Lock Control

Door Lock Actuator Terminal Identification - Liftgate

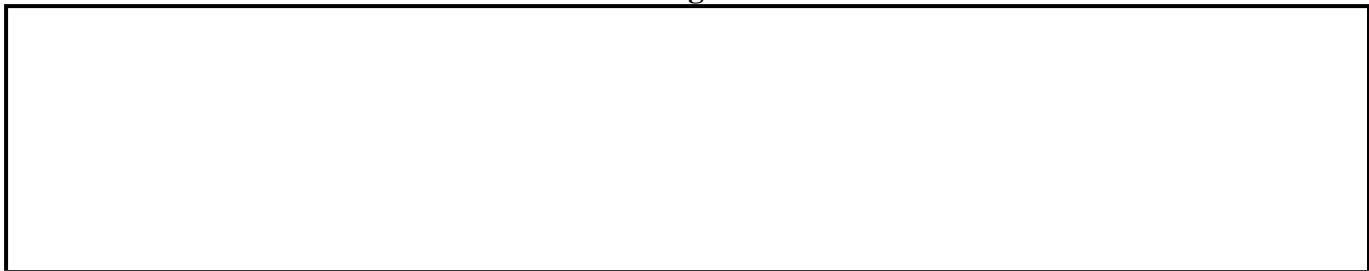

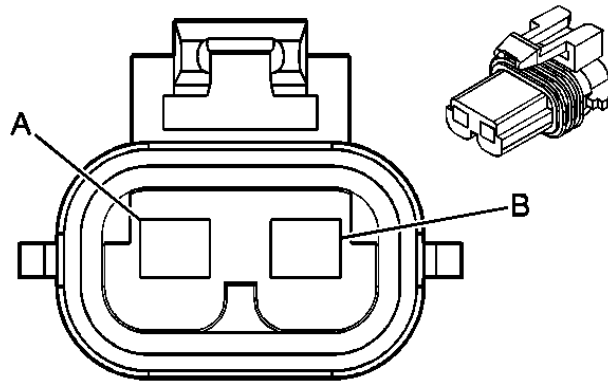

Connector Part Information		<ul style="list-style-type: none"> • 12077900 • 2-Way F Metri-Pack 280 Series Sealed (BK) 	
Pin	Wire Color	Circuit No.	Function
A	TN	294	Door Lock Actuator Unlock Control
B	GY	295	Door Lock Actuator Lock Control

Door Lock Terminal Identification Switch - Rear

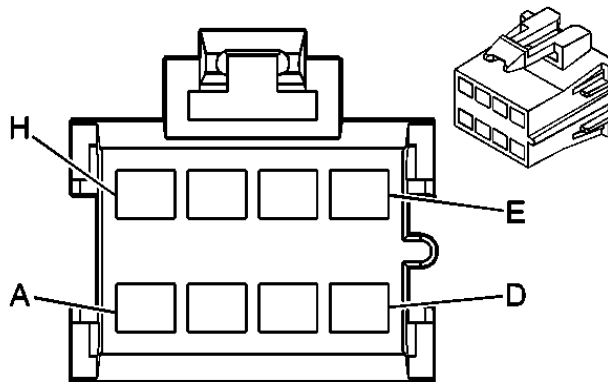

Connector Part Information		<ul style="list-style-type: none"> • 12064998 • 8-Way F Metri-Pack 280 Series (BK) 	
Pin	Wire Color	Circuit No.	Function
A	-	-	Not Used
B	BK	2351	Ground
C	-	-	Not Used
D	L-BU	195	Rear Door Lock Switch Signal

E-G	-	-	Not Used
H	WH	194	Rear Door Unlock Switch Signal

Driver Door Module (DDM) Terminal Identification - C1

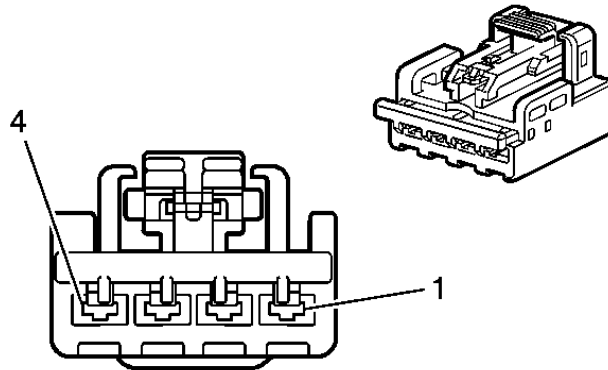

Connector Part Information

- 15393410
- 4-Way F AMP 2.8 mm Sealed (BK)

Pin	Wire Color	Circuit No.	Function
1	BN	165	Power Window Motor Left Front Down Control
2	OG	1240	Battery Positive Voltage
3	D-BU	164	Power Window Motor Left Front Up Control
4	BK	1050	Ground

Driver Door Module (DDM) Terminal Identification - C2

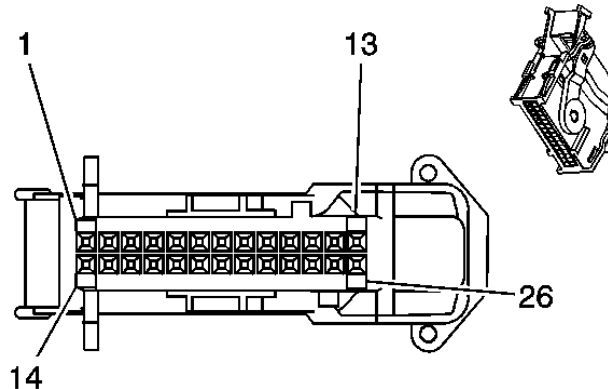

Connector Part Information

- 15398841

• **26-Way F AMP Lever Assist (BK)**

Pin	Wire Color	Circuit No.	Function
1-2	-	-	Not Used
3	BN	1183	Left Front Door Switch Low Reference
4	D-BU	660	Left Front Door Courtesy Lamp Control
5-9	-	-	Not Used
10	GY	1690	Automatic Day/Night Mirror Signal
11	-	-	Not Used
12	PK	1691	Automatic Day/Night Mirror Low Reference
13	D-BU/WH	149	Courtesy Lamp - Left Front Door Supply Voltage
14	OG	4140	Battery Positive Voltage
15	L-GN	262	Driver Door Key Switch Signal
16-17	-	-	Not Used
18	GY/BK	745	Left Front Door Ajar Switch Signal
19	-	-	Not Used
20	TN	294	Door Lock Actuator Unlock Control
21	GY	295	Door Lock Actuator Lock Control
22	BN	1046	DDM Class 2 Serial Data
23-26	-	-	Not Used

Driver Door Module (DDM) Terminal Identification - C3

--

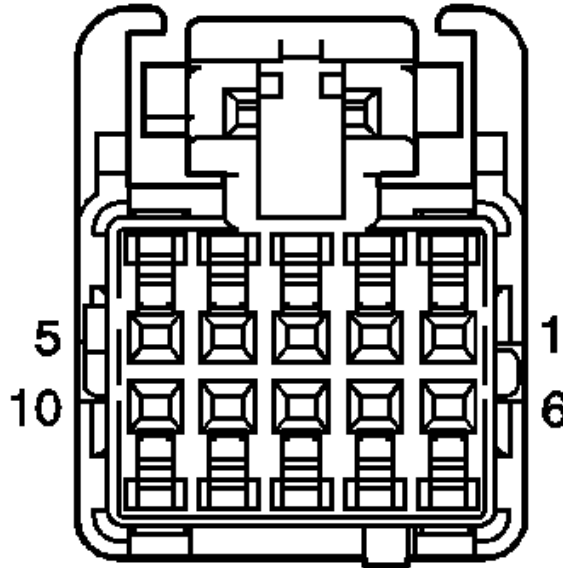

Connector Part Information		<ul style="list-style-type: none"> • 6383393-7 • 10-Way F 0.64 mm Unsealed AMP (BU) 	
Pin	Wire Color	Circuit No.	Function
1-2	-	-	Not Used
3	BK	-	Driver Mirror Heating Element Low Reference
4	PU	-	Mirror Sensor Low Reference
5-6	-	-	Not Used
7	GY	-	Automatic Day/Night Mirror Signal
8	PK	-	Automatic Day/Night Mirror Low Reference
9-10	-	-	Not Used

Driver Door Module (DDM) Terminal Identification - C4

--

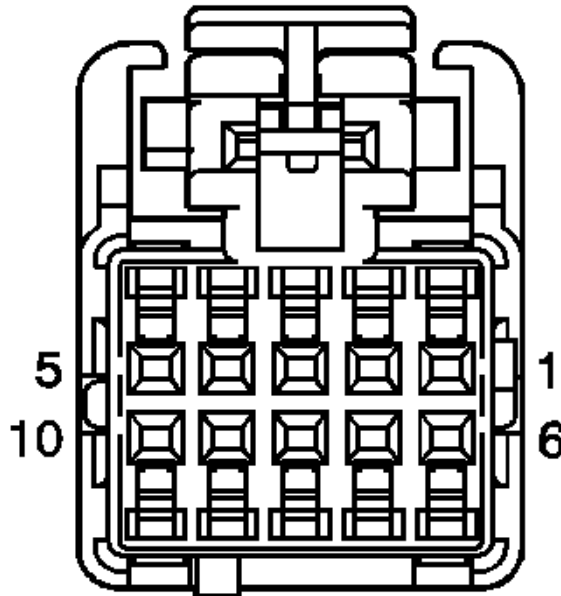

Connector Part Information		<ul style="list-style-type: none"> • 6383393-5 • 10-Way F 0.64 mm Unsealed AMP (BK) 	
Pin	Wire Color	Circuit No.	Function
1	YE	-	Driver Folding Mirror Motor Extend Control
2	OG	-	Mirror Heating Element Supply Voltage
3	RD	-	Driver Mirror Horizontal Position Sensor Signal
4	D-GN	-	5-Volt Reference
5	D-BU	-	Driver Mirror Vertical Position Sensor Signal
6	L-BU	-	Driver Folding Mirror Motor Retract Control
7	YE/WH	-	Driver Mirror Right/Down Motors Common
8	L-BU	-	Driver Mirror Motor Right Control
9	L-GN	-	Driver Mirror Motor Down Control
10	-	-	Not Used

Driver Door Module (DDM) Terminal Identification - C5

--

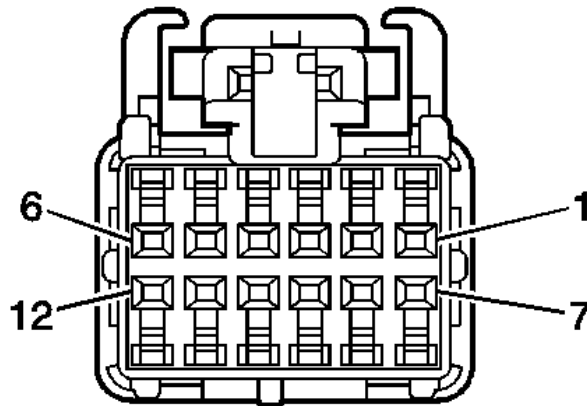

Connector Part Information

- 6383393-4
- 12-Way F AMP 0.64 mm Unsealed (GN)

Pin	Wire Color	Circuit No.	Function
1	WH/BK	-	Medium Heat Indicator Control
2	YE	-	Low Heat Indicator Control
3	GY	-	Back Only Select
4	L-BU	-	Memory/Heated Seat Backlight
5	PK	-	Memory 2 Switch Signal
6	-	-	Not Used
7	D-GN	-	High Heat Indicator Control
8	BK	-	Back Only Indicator
9	D-BU	-	Back and Cushion Select
10	RD	-	Memory 1 Switch Signal
11	BN	-	Memory/Heated Switch Supply Voltage
12	-	-	Not Used

Front Passenger Door Module (FPDM) Terminal Identification - C1

--

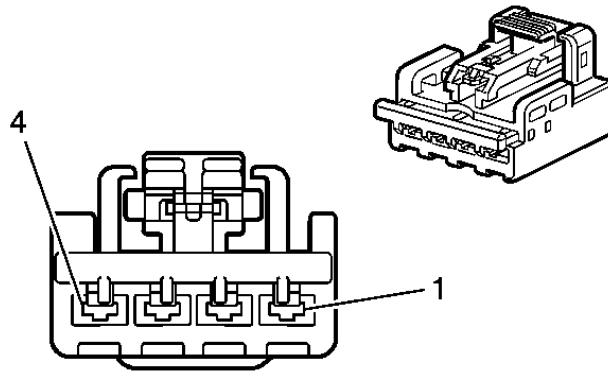

Connector Part Information		<ul style="list-style-type: none"> • 15393410 • 4-Way F 2.8 mm Sealed AMP (BK) 	
Pin	Wire Color	Circuit No.	Function
1	BN	667	Power Window Motor Right Front Down Control
2	OG	1340	Battery Positive Voltage
3	BK	1050	Ground
4	D-BU	666	Power Window Motor Right Front Up Control

Front Passenger Door Module (FPDM) Terminal Identification - C2

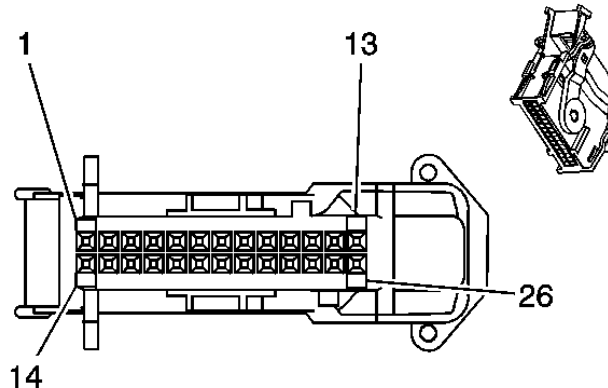

Connector Part Information		<ul style="list-style-type: none"> • 15398841 • 26-Way F AMP Lever Assist (BK) 	
Pin	Wire Color	Circuit No.	Function
1-4	-	-	Not Used
5	BK/WH	746	Right Front Door Ajar Switch Signal

6-7	-	-	Not Used
8	WH	156	Courtesy Lamp-Right Front Door Supply Voltage
9	-	-	Not Used
10	GY	295	Door Lock Actuator Lock Control
11	TN	294	Door Lock Actuator Unlock Control
12-13	-	-	Not Used
14	OG	4240	Battery Positive Voltage
15-18	-	-	Not Used
19	L-BU	661	Right Front Door Courtesy Lamp Control
20	D-GN	1178	Right Front Door Switch Low Reference
21	-	-	Not Used
22	TN	1047	PDM Class 2 Serial Data
23	-	-	Not Used
24	L-GN	265	Passenger Door Key Switch Signal
25-26	-	-	Not Used

Front Passenger Door Module (FPDM) Terminal Identification - C3

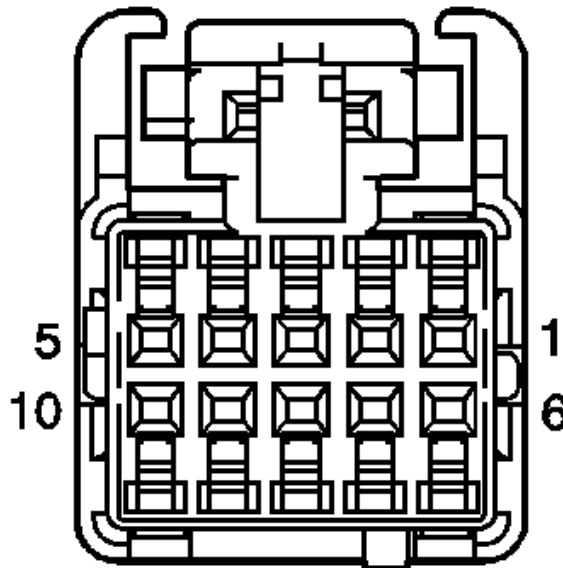

Connector Part Information

- 6383393-7
- 10-Way F 0.64 mm Unsealed AMP (BU)

Pin	Wire Color	Circuit No.	Function

1	RD/WH	-	Passenger Mirror Motor Right Control
2	WH	-	Passenger Mirror Right/Down Motors Common
3	YE	-	Passenger Folding Mirror Motor Extend Control
4	L-BU	-	Passenger Folding Mirror Motor Retract Control
5	-	-	Not Used
6	PU/WH	-	Passenger Mirror Motor Down Control
7	OG	-	Mirror Heating Element Supply Voltage
8	BK	-	Mirror Heating Element Low Reference
9-10	-	-	Not Used

Front Passenger Door Module (FPDM) Terminal Identification - C4

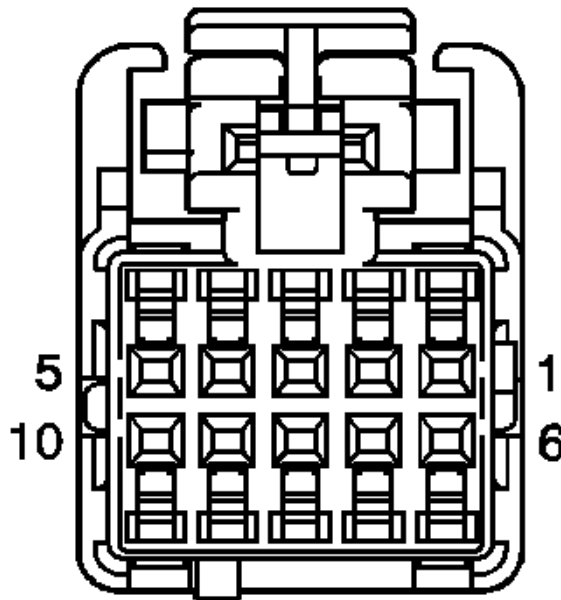

Connector Part Information		<ul style="list-style-type: none"> • 6383393-5 • 10-Way F 0.64 mm Unsealed AMP (BK) 	
Pin	Wire Color	Circuit No.	Function
1	D-GN	-	5-Volt Reference
2	RD	-	Passenger Mirror Vertical Position Sensor Signal
3	PU	-	Low Reference
4	D-BU	-	Passenger Mirror Horizontal Position Sensor Signal
5-10	-	-	Not Used

Front Passenger Door Module (FPDM) Terminal Identification - C5

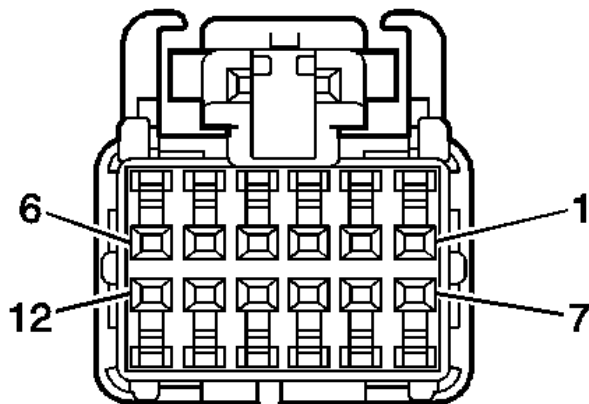

Connector Part Information

- 6383393-4
- 12-Way F AMP 0.64 mm Unsealed (GN)

Pin	Wire Color	Circuit No.	Function
1	YE	-	Low Heat Indicator Control
2	D-GN	-	High Heat Indicator Control
3	D-BU	-	Back Only Select
4	GY	-	Back and Cushion Select
5	-	-	Not Used
6	BN	-	Memory/Heated Seat Switch Supply Voltage
7	BK	-	Back Only Indicator Control
8	WH/BK	-	Medium Heat Indicator Control
9-11	-	-	Not Used
12	L-BU	-	Heated Seat Switch Backlight

Liftgate Ajar Terminal Identification Switch - Left



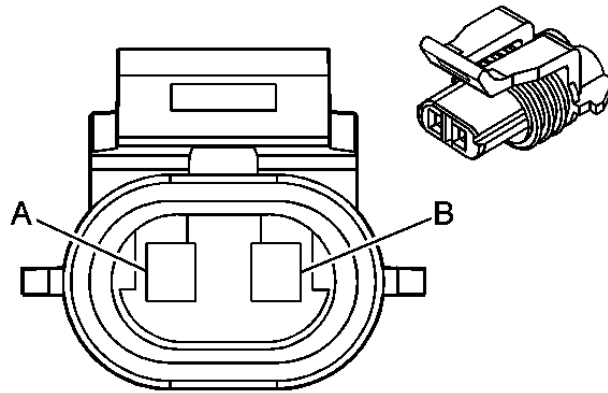

Connector Part Information		<ul style="list-style-type: none"> • 12052644 • 2-Way F Metri-Pack 150 Series Sealed (GY) 	
Pin	Wire Color	Circuit No.	Function
A	BK	1450	Ground
B	PK/BK	1303	Liftgate Ajar Switch Signal

Liftgate Ajar Terminal Identification Switch - Right

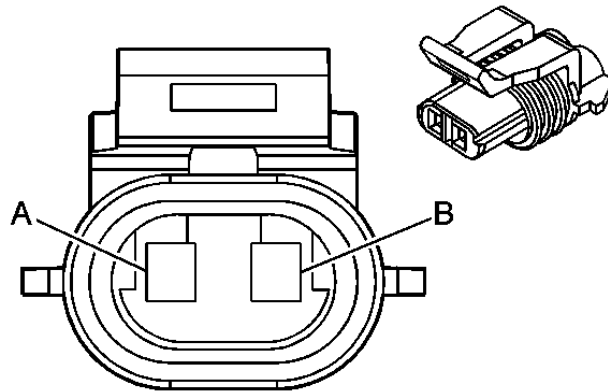

Connector Part Information		<ul style="list-style-type: none"> • 12052644 • 2-Way F Metri-Pack 150 Series Sealed (GY) 	
Pin	Wire Color	Circuit No.	Function
A	BK	1450	Ground
B	PK/BK	1303	Liftgate Ajar Switch Signal

Door Lock Terminal Identification Relay - Liftgate

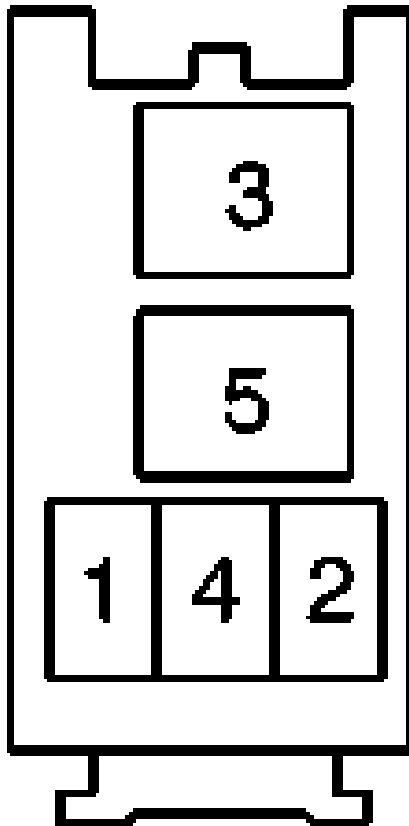

Connector Part Information

- 12065978
- 5-Way F Metri-Pack 480/630 Series Sealed (GY)

Pin	Wire Color	Circuit No.	Function
1	WH	1304	Liftgate Lock Relay Control
2	OG	3140	Battery Positive Voltage
3	GY	295	Door Lock Actuator Lock Control
4	BK	1450	Ground

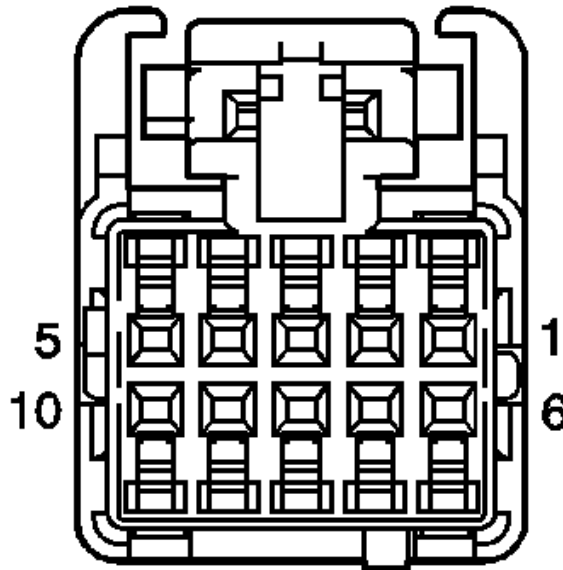
Outside Rear View Mirror - Driver (Driver Door Module (DDM) Terminal Identification - C3)**Connector Part Information**

- 6383393-7
- 10-Way F 0.64 mm Unsealed AMP (BU)

Pin	Wire Color	Circuit No.	Function
1-2	-	-	Not Used
3	BK	-	Driver Mirror Heating Element Low Reference
4	PU	-	Mirror Sensor Low Reference
5-6	-	-	Not Used
7	GY	-	Automatic Day/Night Mirror Signal
8	PK	-	Automatic Day/Night Mirror Low Reference
9-10	-	-	Not Used

Outside Rear View Mirror - Driver (Driver Door Module (DDM) Terminal Identification - C4)

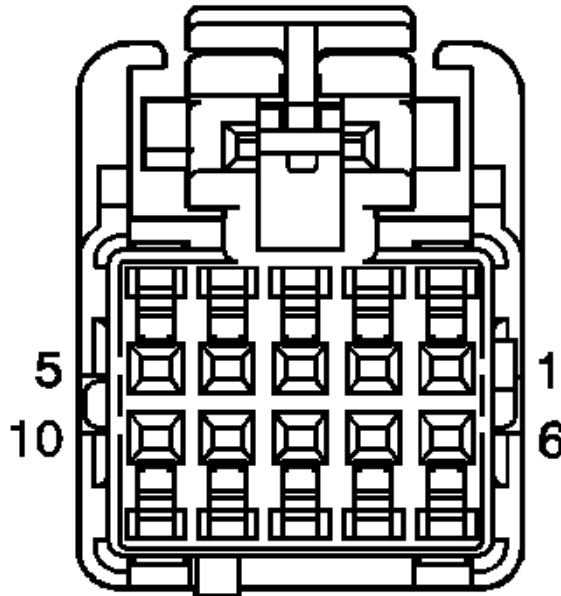

Connector Part Information		<ul style="list-style-type: none"> • 6383393-5 • 10-Way F 0.64 mm Unsealed AMP (BK) 	
Pin	Wire Color	Circuit No.	Function
1	YE	-	Driver Folding Mirror Motor Extend Control
2	OG	-	Mirror Heating Element Supply Voltage
3	RD	-	Driver Mirror Horizontal Position Sensor Signal
4	D-GN	-	5-Volt Reference
5	D-BU	-	Driver Mirror Vertical Position Sensor Signal
6	L-BU	-	Driver Folding Mirror Motor Retract Control
7	YE/WH	-	Driver Mirror Right/Down Motors Common
8	L-BU	-	Driver Mirror Motor Right Control
9	L-GN	-	Driver Mirror Motor Down Control
10	-	-	Not Used

Outside Rear View Mirror - Passenger (Front Passenger Door Module (FPDM) Terminal Identification - C3)

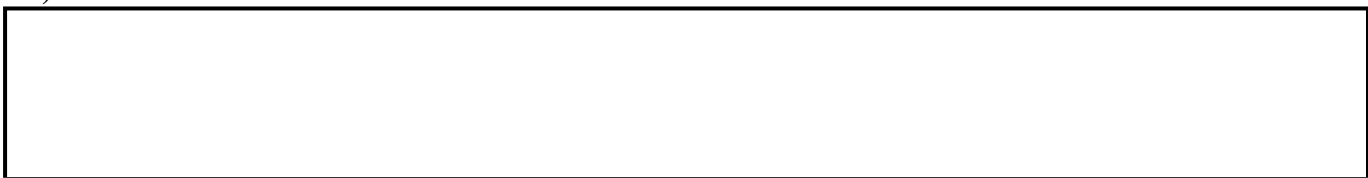

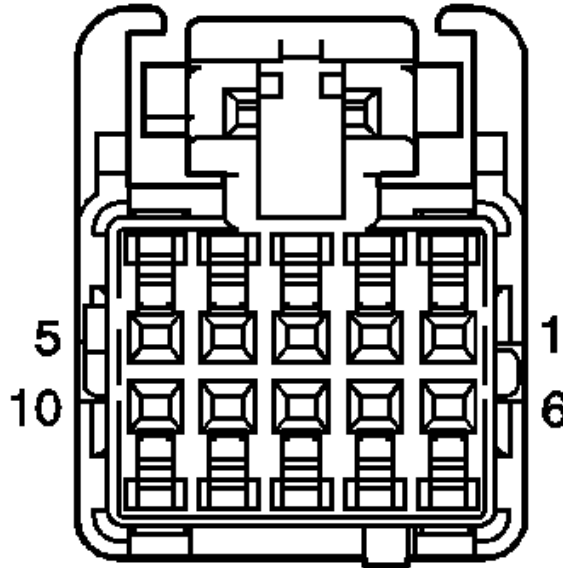

Connector Part Information		<ul style="list-style-type: none"> • 6383393-7 • 10-Way F 0.64 mm Unsealed AMP (BU) 	
Pin	Wire Color	Circuit No.	Function
1	RD/WH	-	Passenger Mirror Motor Right Control
2	WH	-	Passenger Mirror Right/Down Motors Common
3	YE	-	Passenger Folding Mirror Motor Extend Control
4	L-BU	-	Passenger Folding Mirror Motor Retract Control
5	-	-	Not Used
6	PU/WH	-	Passenger Mirror Motor Down Control
7	OG	-	Mirror Heating Element Supply Voltage
8	BK	-	Mirror Heating Element Low Reference
9-10	-	-	Not Used

Outside Rear View Mirror - Passenger (Front Passenger Door Module (FPDM) Terminal Identification - C4)

--

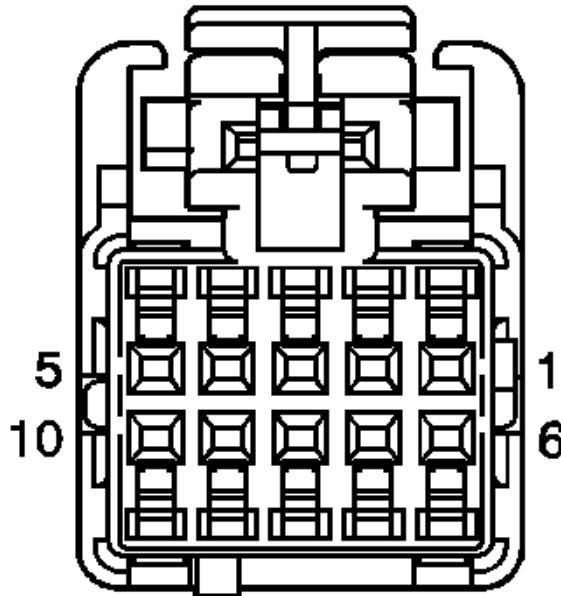

Connector Part Information		<ul style="list-style-type: none"> • 6383393-5 • 10-Way F 0.64 mm Unsealed AMP (BK) 	
Pin	Wire Color	Circuit No.	Function
1	D-GN	-	5-Volt Reference
2	RD	-	Passenger Mirror Vertical Position Sensor Signal
3	PU	-	Low Reference
4	D-BU	-	Passenger Mirror Horizontal Position Sensor Signal
5-10	-	-	Not Used

Window Terminal Identification Motor - Driver

--

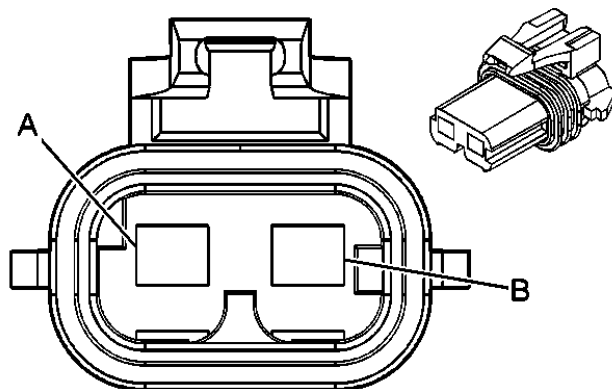

Connector Part Information		<ul style="list-style-type: none"> • 12129487 • 2-Way F Metri-Pack 280 Series Flexlock Sealed (M-GY) 	
Pin	Wire Color	Circuit No.	Function
A	D-BU	164	Power Window Motor Left Front Up Control
B	BN	165	Power Window Motor Left Front Down Control

Window Terminal Identification Motor - Front Passenger

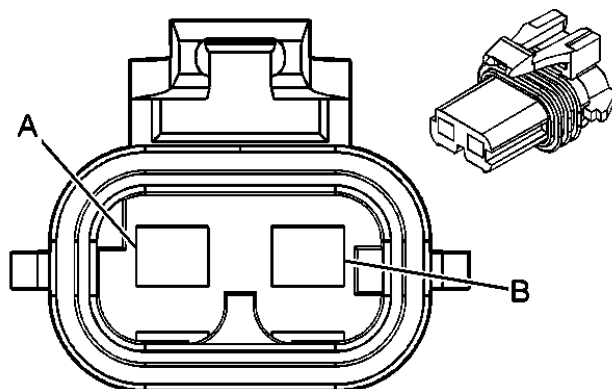

Connector Part Information		<ul style="list-style-type: none"> • 12129487 • 2-Way F Metri-Pack 280 Series Flexlock Sealed (M-GY) 	
Pin	Wire Color	Circuit No.	Function
A	D-BU	666	Power Window Motor Right Front Up Control
B	BN	667	Power Window Motor Right Front Down Control

Window Terminal Identification Motor - LR

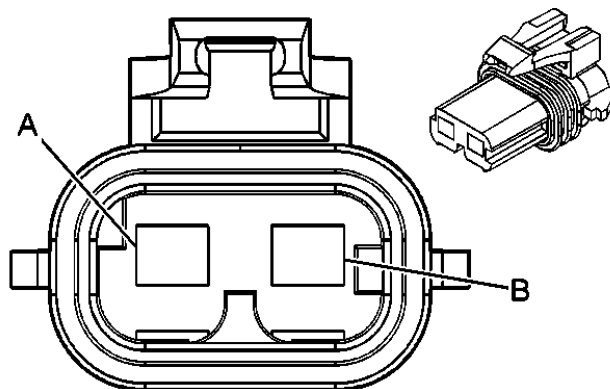

Connector Part Information

- 12129487
- 2-Way F Metri-Pack 280 Series Flexlock Sealed (M-GY)

Pin	Wire Color	Circuit No.	Function
A	BN	669	Power Window Motor Left Rear Down Control
B	D-BU	668	Power Window Motor Left Rear Up Control

Window Terminal Identification Motor - RR

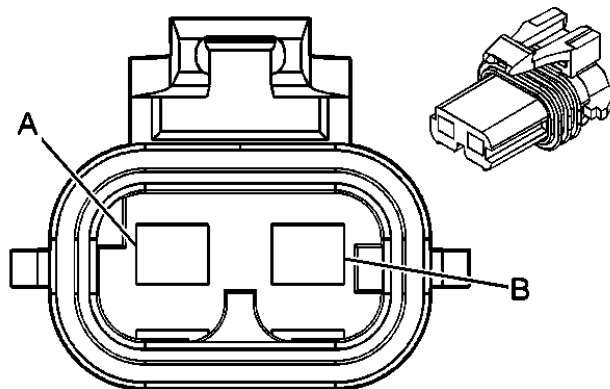

Connector Part Information

- 12129487
- 2-Way F Metri-Pack 280 Series Flexlock Sealed (M-GY)

Pin	Wire Color	Circuit No.	Function
A	BN	671	Power Window Motor Right Rear Down Control
B	D-BU	670	Power Window Motor Right Rear Up Control

Window Terminal Identification Switch - LR

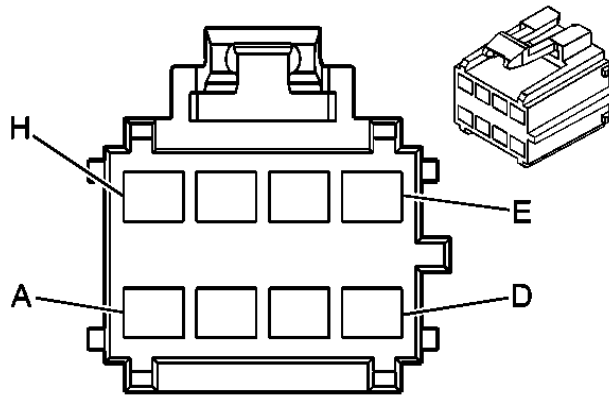

Connector Part Information

- 12191825
- 8-Way F Metri-Pack 280 Series (BN)

Pin	Wire Color	Circuit No.	Function
A	OG	1240	Battery Positive Voltage
B	YE	1187	Power Window Switch Relay Left Rear Down Control
C	WH	1185	Power Window Switch Relay Left Rear Up Control
D	L-BU	2265	Power Window Lockout Left Rear Signal
E	BK	1150	Ground
F	D-BU	668	Power Window Motor Left Rear Up Control
G	BN	669	Power Window Motor Left Rear Down Control
H	BN/WH	230	Instrument Panel Lamps Dimming Control

Window Terminal Identification Switch - RR

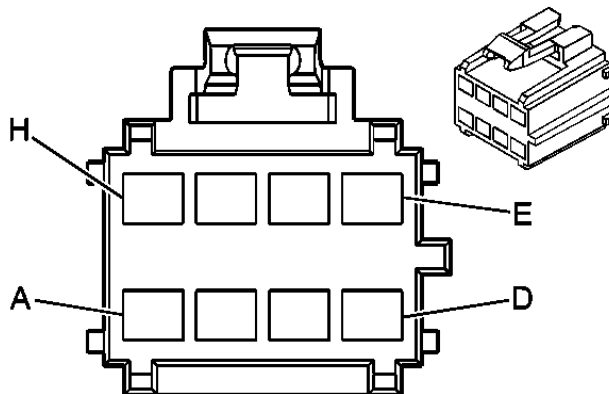

Connector Part Information		<ul style="list-style-type: none"> • 12191825 • 8-Way F Metri-Pack 280 Series (BN) 	
Pin	Wire Color	Circuit No.	Function
A	OG	1340	Battery Positive Voltage
B	D-GN	1188	Power Window Switch Relay Right Rear Down Control
C	GY/BK	1186	Power Window Switch Relay Right Rear Up Control
D	L-GN	2266	Power Window Lockout Right Rear Signal
E	BK	1250	Ground
F	D-BU	670	Power Window Motor Right Rear Up Control
G	BN	671	Power Window Motor Right Rear Down Control
H	BN/WH	230	Instrument Panel Lamps Dimming Control

DIAGNOSTIC INFORMATION AND PROCEDURES

DIAGNOSTIC STARTING POINT - DOORS

Begin the system diagnosis with the **Diagnostic System Check - Door Systems** . The Diagnostic System Check will provide the following information:

- The identification of the control module(s) which command the system.
- The ability of the control module(s) to communicate through the serial data circuit.
- The identification of any stored diagnostic trouble codes (DTCs) and their status.

The use of the Diagnostic System Check will identify the correct procedure for diagnosing the system and where the procedure is located.

DIAGNOSTIC SYSTEM CHECK - DOOR SYSTEMS

Test Description

The numbers below refer to the step numbers on the diagnostic table.

2: Lack of communication may be due to a partial malfunction of the class 2 serial data circuit or due to a total malfunction of the class 2 serial data circuit. The specified procedure will determine the particular condition.

5: The presence of DTCs which begin with "U" indicate some other module is not communicating. The specified procedure will compile all the available information before tests are performed.

Diagnostic System Check - Door Systems

Step	Action	Yes	No
1	Install a scan tool. Does the scan tool power up?	Go to Step 2	Go to Scan Tool Does Not Power Up in Data Link Communications

2	<ol style="list-style-type: none"> 1. Turn ON the ignition, with the engine OFF. 2. Attempt to establish communication with the following modules: <ul style="list-style-type: none"> • The driver door module • The passenger door module • The body control module • The powertrain control module • The instrument panel cluster <p>Does the scan tool communicate with all of the modules?</p>	Go to Step 3	Go to <u>Scan Tool Does Not Communicate with Class 2 Device</u> in Data Link Communications
3	<p>IMPORTANT: The engine may start during the following step. Turn OFF the engine as soon as you have observed the Crank power mode.</p> <ol style="list-style-type: none"> 1. Access the Class 2 Power Mode in the Diagnostic Circuit Check on the scan tool. 2. Rotate the ignition switch through all positions while observing the ignition switch power mode parameter. <p>Does the ignition switch parameter reading match the ignition switch position for all switch positions?</p>	Go to Step 4	Go to <u>Power Mode Mismatch</u> in Body Control System
4	<p>With the scan tool, select the Display DTCs function for each of the following modules:</p> <ul style="list-style-type: none"> • The driver door module • The passenger door module • The body control module • The powertrain control module • The instrument panel cluster 		

	Does the scan tool display any DTCs?	Go to Step 5	Go to Symptoms - Doors
5	Does the scan tool display any DTCs which begin with a "U"?	Go to Scan Tool Does Not Communicate with Class 2 Device in Data Link Communications	Go to Step 6
		Go to Diagnostic Trouble Code (DTC) List in Body Control System	

SCAN TOOL DATA LIST

Driver Door Module/Passenger Door Module

Scan Tool Parameter	Data List	Units Displayed	Typical Data Value
Ignition ON/Engine OFF/Vehicle in PARK/All Doors Closed			
Battery 1 (Low Current)	Data	Volts	12.8
Battery 2 (High Current)	Data	Volts	12.8
Boot S/W Part No.	Module Info.	Decimal	15XXXXXX
Boot S/W Suffix	Module Info.	ASCII	15XXXXXX
Cal. Module 1 Part No.	Module Info.	Decimal	15XXXXXX
Cal. Module 1 Part No.	Module Info.	ASCII	15XXXXXX
Cal. Module 2 Part No.	Module Info.	Decimal	15XXXXXX
Cal. Module 2 Part No.	Module Info.	ASCII	15XXXXXX
Door Ajar Switch	Inputs	On, Off	Off
Door Key Unlock	Inputs	Inactive/Active	Inactive
Door Lock Motor	Outputs	Idle, Lock, Unlock	Idle
Door Lock Switch	Outputs	Idle, Lock, Unlock	Idle
Driver LF Window Switch	Inputs	Idle, Up, Down, Express Down	Idle
Driver RF Window Switch	Inputs	Idle, Up, Down, Express Down	Idle
LR Window Switch	Inputs	Idle, Up, Down	Idle
Memory Switch	Inputs	Idle, Both, Memory 1, Memory 2	Idle
Mirror 5 Volt Reference	Outputs	On, Off	5 Volts
Mirror Fold Motor Current	Data	mA	0
Mirror Folding Operation	Outputs	Idle, Extend, Retract	Idle
Mirror Heater	Outputs	Inactive, Active	Inactive

Mirror Horizontal Position	Data	Volts	Varies
Mirror Motor	Outputs	Idle, Left, Right, Up, Down	Idle
Mirror Select Switch	Inputs	Neutral/Fold, Left, Right	Neutral
Mirror Switch	Inputs	Off, Up, Down, Left, Right, Extend, Retract	Off
Mirror Vertical Position	Data	Volts	Varies
Operational S/W Part No.	Module Information	Decimal	15XXXXXX
Operational S/W Suffix	Module Information	ASCII	XX
Psgr RF Window Switch	Inputs	Idle/Up/Down/Express Down	Idle
Right Rear Window Status	Inputs	Idle, Up, Down	Idle
Window Lockout Switch	Inputs	Inactive/Active	Inactive
Window Lockout LED	Outputs	On, Off	Off
Window Motor Current	Data	mA	0
Window Motor Output	Outputs	Idle, Up, Down	Idle

Body Control Module

Scan Tool Parameter	Data List	Units Displayed	Typical Data Value
Ignition ON/Engine OFF/Vehicle in PARK/All doors closed			
Battery Voltage	Data	Volts	Varies
Door Lock Switch	Inputs	Inactive/Active	Inactive
Door Unlock Switch	Inputs	Inactive/Active	Inactive
Key in Ignition	Inputs	Yes/No	Yes
Left Rear Door Ajar Sw.	Inputs	On/Off	Off
Right Rear Door Ajar Sw.	Inputs	On/Off	Off
Rear Door Lock Relay	Outputs	On/Off	Off
Rear Door Unlock	Outputs	On/Off	Off
Right Rear Window Up Relay	Outputs	Inactive/Active	Inactive
Right Rear Window Down Relay	Outputs	Inactive/Active	Inactive
Left Rear Window Up Relay	Outputs	Inactive/Active	Inactive
Left Rear Window Down Relay	Outputs	Inactive/Active	Inactive

SCAN TOOL DATA DEFINITIONS

The Passenger Door Module (PDM) scan tool data definitions are a brief description of each of the related parameters displayed within the scan tool data display(s) for the PDM.

Back Only Heat Indicator

This data parameter appears in two separate data-lists Inputs and Outputs. While monitoring the inputs for the PDM this parameter reflects the requested state for the back only indicator. When monitoring the outputs the parameter reflects the commanded state for the back only indicator.

Back Only Heat Mode

This data parameter reflects the operating state of the heated seat back only mode of operation. This mode of operation is only available if the heated seat is active or on.

Backlighting Dimming Enabled

This data parameter indicates the status feature. Backlighting is the lighting from behind any text or characters on the PDM switches or faceplate.

Base Software P/N

This is the part number stored within the PDM of the base software set required to activate the PDM. This software set is often referred to as boot software.

Base Software Suffix

This suffix number is the stored indication of the revision level of the base software.

Battery 1 (Low Current)

The battery 1 (low current) parameter provides the voltage level on the battery 1 input. Battery 1 is the low current input provides the power for the PDM's microprocessors and the low current outputs.

Battery 2 (High Current)

The battery 2 (high current) parameter provides the voltage level on the battery 2 input. Battery 2 is the high current input provides the power for the PDM's high current outputs such as the power windows.

Calibration P/N

This is the part number stored within the PDM of the calibration set. The calibration software sets the operational ranges and option levels for each of the PDM's functions. This software set is often referred to as calibration software or calibration.

Calibration Suffix

This suffix number is the stored indication of the revision level of the calibration. This is often referred to as the CAL ID.

Dimming Enable

The dimming enable reflects the state of the dimming for the various indicators located on the PDM.

Dimming Potentiometer

The dimming potentiometer data parameter reflects the level of lighting, in percent for both the backlighting and indicators for the PDM.

Door Ajar Switch

This parameter reflects the current status of the door ajar switch input to the PDM.

Door Lock Motor

This parameter indicates the current status of the door lock motor.

Door Lock Switch

This parameter indicates the current status of the door lock switch.

Heat Indicator High

This data parameter appears in two separate data-lists inputs and outputs. While monitoring the inputs for the PDM this parameter reflects the requested state for the heat indicator low. When monitoring the outputs the parameter reflects the commanded state for the heat indicator low.

Heat Indicator Low

This data parameter appears in two separate data-lists inputs and outputs. While monitoring the inputs for the PDM this parameter reflects the requested state for the heat indicator low. When monitoring the outputs the parameter reflects the commanded state for the heat indicator low.

Heat Indicator Medium

This data parameter appears in two separate data-lists inputs and outputs. While monitoring the inputs for the PDM this parameter reflects the requested state for the heat indicator medium. When monitoring the outputs the parameter reflects the commanded state for the heat indicator medium.

Heated Seat Mode

This parameter indicates the status of the heated seat feature.

Right Front Window Status

This parameter indicates the status of the right front window.

Memory Switch

This data parameter provides the status of the memory switch.

Mirror 5 Volt Reference

This data parameter provides a status indication of the 5-volt reference circuit for the OSRV position sensors.

Mirror Fold Motor Current

This parameter provides the detected amount of current (in mA) that is required to perform the active mirror fold action.

Mirror Folding Operation

This parameter indicates the mirror fold operation currently in process.

Mirror Heater

This parameter indicates the operational state of the mirror heater.

Mirror Horizontal Position

This parameter provides OSRV mirror horizontal position in volts.

Mirror Motor

This parameter provides information regarding the state of operation the mirror is currently activating.

Mirror Select Switch

This parameter indicates the current mirror select switch position.

Mirror Switch Backlight

The mirror switch backlight data parameter reflects the level of backlighting, in percent for the mirror switch.

Mirror Switch Horizontal

This data parameter provides the current status of the OSRV horizontal position adjustment switch.

Mirror Switch Vertical

This data parameter provides the current status of the OSRV vertical position adjustment switch.

Mirror Vertical Position

This parameter provides OSRV mirror vertical position information in volts.

Program Software P/N

This is the part number stored indication of the revision level of the program software.

Program Software Suffix

This suffix number is the stored indication of the revision level of the program software.

Right Front Window Status

This parameter indicates the status of the right front window.

Right Rear Window Status

This parameter indicates the status of the right rear window.

Window Motor Current

This parameter indicates the active status of the window lockout feature.

Window Motor Output

This parameter reflects the state of the PDM output to the window motor.

Window Switch Backlight

The window switch backlight data parameter reflects the level of backlighting, in percent for the window switch.

DIAGNOSTIC TROUBLE CODE (DTC) LIST

Diagnostic Trouble Code (DTC) List

DTC	Diagnostic Procedure	Module(s)
B1023	<u>DTC B1023</u>	DDM/PDM
B1544	<u>DTC B1544, B1600, or B1605</u>	DDM/PDM
B1580	<u>DTC B1580, B1590, B1610, or B1620</u>	DDM/PDM
B1590	<u>DTC B1580, B1590, B1610, or B1620</u>	DDM/PDM
B1600	<u>DTC B1544, B1600, or B1605</u>	DDM/PDM
B1605	<u>DTC B1544, B1600, or B1605</u>	DDM/PDM
B1610	<u>DTC B1580, B1590, B1610, or B1620</u>	DDM/PDM
B1620	<u>DTC B1580, B1590, B1610, or B1620</u>	DDM/PDM

B1640	<u>DTC B1640 or B1645</u>	DDM/PDM
B1645	<u>DTC B1640 or B1645</u>	DDM/PDM
B1722	<u>DTC B1722</u>	DDM/PDM
B3808	<u>DTC B3808</u>	BCM
B3809	<u>DTC B3809</u>	BCM
B3819	<u>DTC B3819</u>	BCM
B3820	<u>DTC B3820</u>	BCM
B3821	<u>DTC B3821</u>	BCM
B3822	<u>DTC B3822</u>	BCM
B3823	<u>DTC B3823</u>	BCM
B3824	<u>DTC B3824</u>	BCM
B3825	<u>DTC B3825</u>	BCM

DTC B1023

Circuit Description

The switch that failed and generated this diagnostic trouble code (DTC) is part of the DDM or the PDM. When a switch is activated, the DDM/PDM then either actuates the appropriate component or sends a message over the serial data link to the appropriate module to actuate the appropriate component.

Conditions for Running the DTC

- System voltage is between 9.0 and 16 volts.
- Ignition switch is in the ON position.

Conditions for Setting the DTC

If the DDM or the PDM receives multiple inputs from a single switch at the same time for more than 160 milliseconds, the DDM/PDM sets the DTC. The following switches will set this DTC:

- The door lock switch
- The power window switch
- The window lockout switch
- The mirror select switch

Action Taken When the DTC Sets

The DDM/PDM ignores the continuous inputs from the switch. The DDM/PDM will not respond to the invalid inputs as a command for the component. The DDM/PDM will respond to all other valid switch inputs.

Conditions for Clearing the DTC

When the switch input status changes, the DDM/PDM clears this current DTC and stores the DTC as a history

DTC. The history DTC will clear either after 50 ignition switch cycles without a repeated failure or in response to a scan tool command.

DTC B1023

Step	Action	Yes	No
Schematic Reference: <u>Power Window Schematics</u> or <u>Door Lock/Indicator Schematics</u>			
Connector End View Reference: <u>Power Door Systems Connector End Views</u>			
1	Did you perform the Door Systems Diagnostic System Check?	Go to Step 2	Go to Diagnostic System Check - Door Systems
2	<ol style="list-style-type: none"> 1. Install a scan tool. 2. Turn ON the ignition, with the engine OFF. 3. Observe the appropriate switch parameter in the input list using the scan tool. Does the scan tool display an inactive state?	Go to Step 3	Go to Step 4
3	<ol style="list-style-type: none"> 1. Activate the switch in both directions. 2. Observe the switch parameter using the scan tool. Does the switch parameter change state?	Go to Testing for Intermittent Conditions and Poor Connections in Wiring Systems	Go to Step 4
4	Inspect for poor connections/terminal tension at the door module harness connector. Refer to Testing for Intermittent Conditions and Poor Connections and Connector Repairs in Wiring Systems. Did you find and correct the condition?	Go to Step 6	Go to Step 5
5	Replace the appropriate door module. Refer to Switch Replacement - Door Lock and Side Window - Driver or Switch Replacement - Door Lock and Side Window - Passenger . Did you complete the replacement?	Go to Step 6	-
6	<ol style="list-style-type: none"> 1. Clear the DTCs using the scan tool. 2. Operate the vehicle within the Conditions for Running the DTC as specified in the supporting text. Does the DTC reset?	Go to Step 2	System OK

DTC B1544, B1600, OR B1605

Circuit Description

The driver door and passenger door modules supply battery positive voltage and ground on opposing mirror motor control circuits upon receipt of a mirror switch activation or a class 2 message commanding mirror

control, memory recall or mirror tilt in reverse functions.

Conditions for Running the DTC

- System voltage must be between 9.0-16.0 volts.
- The mirror motor control circuits must be active.

Conditions for Setting the DTC

- If the mirror motor control circuits are switched to battery voltage and the mirror motor control circuit is shorted to ground.
- If the mirror motor control circuits are switched to ground and the mirror motor control circuit is shorted to battery voltage.

Action Taken When the DTC Sets

The outside rearview mirror will not operate properly on all axes.

Conditions for Clearing the DTC

When the fault is no longer present, the door module changes the current DTC to a history DTC. The door module will clear the history DTC after 50 fault free ignition cycles, or in response to a scan tool command.

DTC B1544, B1600, or B1605

Step	Action	Yes	No
Schematic Reference: <u>Outside Mirror Schematics</u> Connector End View Reference: <u>Power Door Systems Connector End Views</u>			
1	Did you perform the Door Systems Diagnostic System Check?	Go to Step 2	Go to <u>Diagnostic System Check - Door Systems</u>
2	1. Turn ON the ignition, with the engine OFF. 2. Activate the mirror switch in the up, down left and right positions. Does the mirror move properly with each activation?	Go to <u>Testing for Intermittent Conditions and Poor Connections</u> in Wiring Systems	Go to Step 3
3	1. Turn OFF the ignition. 2. Disconnect the mirror from the appropriate door module. 3. Turn ON the ignition, with the engine OFF. 4. Probe each of the mirror motor down, right and up/left control circuit pins at the door module one at a time with a test lamp that is connected to a good ground.		

	Did the test lamp illuminate at any of the test points?	Go to Step 7	Go to Step 4
4	<ol style="list-style-type: none"> 1. Connect a test lamp between the mirror motor down control circuit pin and a good ground. 2. Activate the mirror switch to the down position. <p>Does the test lamp illuminate?</p>	Go to Step 5	Go to Step 8
5	<ol style="list-style-type: none"> 1. Connect a test lamp between the mirror motor right control circuit pin and a good ground. 2. Activate the mirror switch to the right position. <p>Does the test lamp illuminate?</p>	Go to Step 6	Go to Step 8
6	<ol style="list-style-type: none"> 1. Connect a test lamp between the mirror motor up/left control circuit pin and a good ground. 2. Activate the mirror switch to the up and left positions. <p>Does the test lamp illuminate?</p>	Go to Step 7	Go to Step 8
7	<p>Inspect for poor connection at the harness connector of the appropriate door module. Refer to Testing for Intermittent Conditions and Poor Connections in Wiring Systems.</p> <p>Did you find and correct the conditions?</p>	Go to Step 10	Go to Step 9
8	<p>IMPORTANT: perform the set up procedure for the appropriate door module. Refer to Service Programming System (SPS) in Programming.</p> <p>Replace the appropriate door module. Refer to Switch Replacement - Door Lock and Side Window - Driver or Switch Replacement - Door Lock and Side Window - Passenger .Did you complete the replacement?</p>	Go to Step 10	-
9	<p>Replace the mirror. Refer to Mirror Replacement . Did you complete the replacement?</p>	Go to Step 10	-
10	<ol style="list-style-type: none"> 1. Use the scan tool in order to clear the DTCs. 2. Operate the vehicle within the Conditions for Running the DTC as specified in the supporting text. <p>Does the DTC reset?</p>	Go to Step 2	System OK

Circuit Description

The mirror horizontal and vertical position sensors are potentiometers. The Driver Door Module (DDM) and Passenger Door Module (PDM) provide these sensors with a 5 volt reference circuit and a low reference circuit. The DDM/PDM monitors the horizontal and vertical position sensor signal circuits which change values based on mirror position. These voltage values are used to determine mirror position and can be set into memory. When the DDM/PDM receives a memory recall request, the DDM/PDM will control the power mirror to the memory position based on the horizontal and vertical position sensor signal values.

Conditions for Running the DTC

Battery voltage must be between 9.0-16.0 volts.

Conditions for Setting the DTC

The horizontal and/or vertical position sensor signal(s) are greater than 4.75 volts or less than 0.50 volts.

Action Taken When the DTC Sets

Memory movements on the malfunctioning axis are disabled.

Conditions for Clearing the DTC

When the fault is no longer present, the DDM/PDM changes the current DTC to a history DTC. The DDM/PDM will clear the history DTC after 50 fault free ignition cycles.

Diagnostic Aids

- If DTC B1580 is set by itself, the left horizontal position sensor signal circuit maybe open, shorted to ground or battery
- If DTC B1590 is set by itself, the left vertical position sensor signal circuit maybe open, shorted to ground or battery
- If DTC B1610 is set by itself, the right horizontal position sensor signal circuit maybe open, shorted to ground or battery
- If DTC B1620 is set by itself, the right vertical position sensor signal circuit maybe open, shorted to ground or battery.
- If DTCs B1580 and B1590 are both set, the left 5 volt reference or low reference circuit(s) maybe open, shorted to ground or battery.
- If DTCs B1610 and B1620 are both set, the right 5 volt reference or low reference circuit(s) maybe open, shorted to ground or battery.

DTC B1580, B1590, B1610, or B1620

Step	Action	Value (s)	Yes	No
Schematic Reference: <u>Outside Mirror Schematics</u>				
Connector End View Reference: <u>Power Door Systems Connector End Views</u>				

1	Did you perform the Door Systems Diagnostic System Check?	-	Go to Step 2	Go to <u>Diagnostic System Check - Door Systems</u>
2	<ol style="list-style-type: none"> 1. Install a scan tool. 2. Turn ON the ignition, with the engine OFF. 3. With the scan tool, observe the mirror horizontal and vertical position parameters in the Driver Door Module (DDM) and Passenger Door Module (PDM) data lists. 4. Operate both the left and right mirrors through the full range of movements. <p>Does the scan tool indicate that the left and right mirror horizontal and vertical position parameters are within the specified range?</p>	0.50-4.75 V	Go to <u>Testing for Intermittent Conditions and Poor Connections</u> in Wiring Systems	Go to Step 3
3	Is there a horizontal and vertical DTC set on the same mirror?	-	Go to Step 6	Go to Step 4
4	<ol style="list-style-type: none"> 1. Turn OFF the ignition. 2. Disconnect the appropriate mirror. 3. Turn ON the ignition, with the engine OFF. 4. With a scan tool, observe the appropriate mirror position parameter. <p>Does the scan tool indicate that the mirror position parameter is less than the specified value?</p>	0.50 V	Go to Step 5	Go to Step 8
5	<ol style="list-style-type: none"> 1. Turn OFF the ignition. 2. Connect a 3 amp fused jumper wire between the 5 volt reference circuit and the mirror position signal circuit of the appropriate mirror position sensor at the mirror harness connector. 3. Turn ON the ignition, with the engine OFF. 4. With a scan tool, observe the mirror position parameter. <p>Does the scan tool indicate that the mirror position parameter is within the specified range?</p>	4.75 - 5.25 V	Go to Step 12	Go to Step 9

6	<ol style="list-style-type: none"> 1. Turn OFF the ignition. 2. Disconnect the appropriate mirror. 3. Turn ON the ignition, with the engine OFF. 4. Measure the voltage between the 5 volt reference circuit at the mirror harness connector and a good ground. <p>Does the voltage measure within the specified range?</p>	4.75 - 5.25 V	Go to Step 7	Go to Step 10
7	<p>Measure the voltage between the 5 volt reference circuit and the low reference circuit at the mirror harness connector.</p> <p>Does the voltage measure within the specified range?</p>	4.75 - 5.25 V	Go to Step 12	Go to Step 11
8	<p>Test for a short to voltage on the mirror position signal circuit. Refer to Circuit Testing and Wiring Repairs in Wiring Systems.</p> <p>Did you find and correct the condition?</p>	-	Go to Step 16	Go to Step 13
9	<p>Test the mirror position signal circuit for an open, high resistance, short to ground or battery. Refer to Circuit Testing and Wiring Repairs in Wiring Systems.</p> <p>Did you find and correct the condition?</p>	-	Go to Step 16	Go to Step 13
10	<p>Test the 5 volt reference circuit for an open, high resistance, short to ground or battery. Refer to Circuit Testing and Wiring Repairs in Wiring Systems.</p> <p>Did you find and correct the condition?</p>	-	Go to Step 16	Go to Step 13
11	<p>Test the low reference circuit for an open, high resistance or short to battery. Refer to Circuit Testing and Wiring Repairs in Wiring Systems.</p> <p>Did you find and correct the condition?</p>	-	Go to Step 16	Go to Step 13
12	<p>Inspect for poor connections at the harness connector of the power mirror. Refer to Testing for Intermittent Conditions and Poor Connections and Connector Repairs in Wiring Systems.</p> <p>Did you find and correct the condition?</p>	-	Go to Step 16	Go to Step 14
13	<p>Inspect for poor connections at the harness connector of the DDM/PDM. Refer to Testing for Intermittent Conditions and Poor Connections and Connector Repairs in Wiring Systems.</p>	-		

	Did you find and correct the condition?		Go to Step 16	Go to Step 15
14	Replace the power mirror. Refer to <u>Mirror Replacement</u> . Did you complete the replacement?	-	Go to Step 16	-
15	IMPORTANT: Perform the set up procedure for the appropriate door module. Refer to <u>Service Programming System (SPS) in Programming.</u> Replace the appropriate door module. Refer to <u>Switch Replacement - Door Lock and Side Window - Driver</u> or <u>Switch Replacement - Door Lock and Side Window - Passenger</u> .Did you complete the replacement?	-	Go to Step 16	-
16	1. Use the scan tool in order to clear the DTCs. 2. Operate the vehicle within the Conditions for Running the DTC as specified in the supporting text. Does the DTC reset?	-	Go to Step 2	System OK

DTC B1640 OR B1645

Circuit Description

The DDM and PDM supply battery voltage to the mirror heating element supply voltage circuit upon receipt of a class 2 message from the BCM indicating that the rear defrost system is active. The DDM and PDM also supply a constant ground for the mirror heating elements.

Conditions for Running the DTC

- System voltage between 9.0-16.0 volts
- Ignition switch is in the ON position

Conditions for Setting the DTC

When the DDM and PDM supply battery voltage to the mirror heating element supply voltage circuit and it's shorted to ground.

Action Taken When the DTC Sets

The DDM and PDM will ignore the class 2 message and stop supplying battery voltage on the shorted circuit.

Conditions for Clearing the DTC

When the short circuit is no longer present, the DDM/PDM will clear the current DTC and store the DTC as a history DTC. The history DTC will clear after 50 fault free ignition cycles or in response to a scan tool command.

DTC B1640 or B1645

Step	Action	Yes	No
Schematic Reference: Outside Mirror Schematics Connector End View Reference: Power Door Systems Connector End Views			
1	Did you perform the Door System Diagnostic System Check?	Go to Step 2	Go to Diagnostic System Check - Door Systems
2	1. Turn ON the ignition, with the engine OFF. 2. Activate the rear defroster switch. Does DTC B1640 or B1645 set as current in the DDM or PDM?	Go to Step 3	Go to Testing for Intermittent Conditions and Poor Connections in Wiring Systems
3	1. Turn OFF the ignition. 2. Disconnect the appropriate heated mirror. 3. Turn ON the ignition, with the engine OFF. 4. Activate the rear defroster switch. Does DTC B1640 or B1645 set as current in the DDM or PDM?	Go to Step 5	Go to Step 4
4	Inspect for poor connections at the heated mirror. Refer to Testing for Intermittent Conditions and Poor Connections and to Connector Repairs in Wiring Systems. Did you find and correct the condition?	Go to Step 8	Go to Step 6
5	Inspect for poor connections at the harness connector of the appropriate door module. Refer to Testing for Intermittent Conditions and Poor Connections and to Connector Repairs in Wiring Systems. Did you find and correct the condition?	Go to Step 8	Go to Step 7
6	Replace the heated mirror. Refer to Mirror Replacement . Did you complete the replacement?	Go to Step 8	-
7	Replace the appropriate door module. Refer to Switch Replacement - Door Lock and Side Window - Driver or Switch Replacement - Door Lock and Side Window - Passenger . Did you complete the replacement?	Go to Step 8	-
8	1. Use the scan tool in order to clear the DTCs. 2. Operate the vehicle within the Conditions for Running the DTC. Does the DTC reset?	Go to Step 2	System OK

DTC B1722

Circuit Description

The Driver Door Module (DDM) and Passenger Door Module (PDM) switch the mirror fold motor control circuits to battery voltage and ground in response to mirror extend or retract command.

Conditions for Running the DTC

- Battery voltage must be between 9.0-16.0 volts.
- The ignition switch is in the ON position.
- A mirror extend or retract function must be active.

Conditions for Setting the DTC

When the DDM or PDM switch the mirror fold motor control circuits to battery voltage and ground and one of the mirror fold motor control circuits are shorted to ground, shorted to battery or open.

Action Taken When the DTC Sets

The DDM or PDM will stop supplying battery voltage and ground to the mirror fold motor and the folding mirrors will be inoperative.

Conditions for Clearing the DTC

When the fault is no longer present, the door module changes the current DTC to a history DTC. The door module will clear the history DTC after 50 fault free ignition cycles, or in response to a scan tool command.

DTC B1722

Step	Action	Value (s)	Yes	No
Schematic Reference: <u>Outside Mirror Schematics</u> Connector End View Reference: <u>Power Door Systems Connector End Views</u>				
1	Did you perform the Door Systems Diagnostic System Check?	-	Go to Step 2	Go to <u>Diagnostic System Check - Door Systems</u>
2	<ol style="list-style-type: none">1. Install a scan tool.2. Turn ON the ignition, with the engine OFF.3. Place the mirror select switch in the neutral/fold position.4. Place the mirror direction switch in both the left/extend and right/retract positions. Does DTC B1722 set as a current DTC?	-	Go to Step 3	Go to <u>Testing for Intermittent Conditions and Poor Connections</u> in Wiring Systems

3	<ol style="list-style-type: none"> 1. Connect a test lamp to a good ground. 2. Backprobe both of the mirror fold motor control circuits one at a time with the test lamp. <p>Does the test lamp illuminate at either test point?</p>	-	Go to Step 6	Go to Step 4
4	<ol style="list-style-type: none"> 1. Connect a test lamp to battery voltage. 2. Backprobe both of the mirror fold motor control circuits one at a time with the test lamp. <p>Does the test lamp illuminate at either test point?</p>	-	Go to Step 6	Go to Step 5
5	<ol style="list-style-type: none"> 1. Disconnect the power mirror. 2. Test for continuity through the mirror fold motor and the mirror fold motor control circuits. <p>Is there continuity?</p>	-	Go to Step 7	Go to Step 6
6	<p>Inspect for poor connections at the harness connector of the power mirror. Refer to Testing for Intermittent Conditions and Poor Connections in Wiring Systems. Did you find and correct the condition?</p>	-	Go to Step 10	Go to Step 8
7	<p>Inspect for poor connections at the harness connector of the appropriate door module. Refer to Testing for Intermittent Conditions and Poor Connections in Wiring Systems. Did you find and correct the condition?</p>	-	Go to Step 10	Go to Step 9
8	<p>Replace the appropriate power mirror. Refer to Mirror Replacement . Did you complete the replacement?</p>	-	Go to Step 10	-
9	<p>IMPORTANT: Perform the set up procedure for the driver door module. Refer to Service Programming System (SPS) in Programming.</p> <p>Replace the appropriate door module. Refer to Switch Replacement - Door Lock and Side Window - Driver or Switch Replacement - Door Lock and Side Window - Passenger .Did you complete the replacement?</p>	-	Go to Step 10	-
10	<ol style="list-style-type: none"> 1. Use the scan tool in order to clear the DTCs. 2. Operate the vehicle within the Conditions for Running the DTC as specified in the supporting text. <p>Does the DTC reset?</p>	-	Go to Step 2	System OK

DTC B3808

Circuit Description

The Body Control Module (BCM) internally grounds the door lock relay control circuit for the rear door lock relay when it receives a Class 2 message from the Driver Door Module (DDM) or Passenger Door Module (PDM). When the BCM grounds the door lock relay control circuit the rear door lock relay is energized and locks the rear doors.

Conditions for Running the DTC

- Battery voltage is between 9.0-16.0 volts.
- The DTC will set if the rear door lock function is active or inactive.

Conditions for Setting the DTC

The DTC will set if the door lock relay control circuit is shorted to ground or open for more than one second.

Action Taken When the DTC Sets

- If a short to ground is present on the door lock relay control circuit, the door lock relay will be energized and the rear door lock actuators will be held in the lock position and will not unlock.
- If an open condition is present on the door lock relay control circuit, the rear doors will unlock but not lock.

Conditions for Clearing the DTC

When the fault is no longer present, the BCM changes the current DTC to a history DTC. The BCM will clear the history DTC after 50 fault free ignition cycles.

Diagnostic Aids

- DTC B3808 could also set if the door lock relay winding is open.
- If both DTC B3808 and B3809 are set as current, the battery positive voltage circuit or the LOCKS fuse could be open. If the LOCKS fuse is open, the cause is most likely one of the following:
 - A short to ground in the relay battery positive voltage circuit.
 - A short to ground in the door lock actuator lock or unlock control circuits.

Test Description

The numbers below refer to the step numbers on the diagnostic table.

- 2:** Listen for an audible click when the rear door lock relay operates. Command both the ON and OFF states. Repeat the commands as necessary.
- 3:** Tests for voltage at the coil side of the rear door lock relay. The LOCKS fuse supplies power to the coil side of the rear door lock relay.

4: Verifies that the body control module is providing ground to the rear door lock relay.

5: Tests if ground is constantly being applied to the rear door lock relay.

DTC B3808

Step	Action	Yes	No
Schematic Reference: Door Lock/Indicator Schematics			
Connector End View Reference: Power Door Systems Connector End Views			
1	Did you perform the Door Systems Diagnostic System Check?	Go to Step 2	Go to Diagnostic System Check - Door Systems
2	<ol style="list-style-type: none"> 1. Install a scan tool. 2. With a scan tool, command the rear door lock relay ON and OFF. <p>Does the rear door lock relay turn ON and OFF with each command?</p>	Go to Testing for Intermittent Conditions and Poor Connections in Wiring Systems	Go to Step 3
3	<ol style="list-style-type: none"> 1. Remove the rear door lock relay. 2. Probe the battery positive voltage circuit of the rear door lock relay with a test lamp that is connected to a good ground. <p>Does the test lamp illuminate?</p>	Go to Step 4	Go to Step 8
4	<ol style="list-style-type: none"> 1. Connect a test lamp between the door lock relay control circuit and the battery positive voltage circuit of the rear door lock relay. 2. With a scan tool, command the rear door lock ON and OFF. <p>Does the test lamp turn ON and OFF with each command?</p>	Go to Step 9	Go to Step 5
5	Does the test lamp remain illuminated without being commanded?	Go to Step 7	Go to Step 6
6	Test the door lock relay control circuit of the rear door lock relay for an open. Refer to Circuit Testing and Wiring Repairs in Wiring Systems. Did you find and correct the condition?	Go to Step 14	Go to Step 10
7	Test the door lock relay control circuit of the rear door lock relay for a short to ground or an open. Refer to Circuit Testing and Wiring Repairs in Wiring Systems. Did you find and correct the condition?	Go to Step 14	Go to Step 10
	Test for an open or short to ground in the battery positive voltage circuit of the rear door lock relay.		

8	Refer to Circuit Testing and Wiring Repairs in Wiring Systems. Did you complete the repair?	Go to Step 14	Go to Step 11
9	Inspect for poor connections at the rear door lock relay. Refer to Testing for Intermittent Conditions and Poor Connections and Connector Repairs in Wiring Systems. Did you find and correct the condition?	Go to Step 13	Go to Step 12
10	Inspect for poor connections at the harness connector of the body control module. Refer to Testing for Intermittent Conditions and Poor Connections and Connector Repairs in Wiring Systems. Did you find and correct the condition?	Go to Step 14	Go to Step 13
11	Repair the short to ground in the door lock actuator lock or unlock circuits. Refer to Wiring Repairs in Wiring Systems. Did you complete the repair?	Go to Step 14	-
12	Replace the rear door lock relay. Did you complete the replacement?	Go to Step 14	-
13	IMPORTANT: Perform the set up procedure for the body control module. Replace the body control module. Refer to Body Control Module Replacement in Body Control System. Did you complete the replacement?	Go to Step 14	-
14	1. Use the scan tool in order to clear the DTCs. 2. Operate the vehicle within the Conditions for Running the DTC as specified in the supporting text. Does the DTC reset?	Go to Step 2	System OK

DTC B3809

Circuit Description

The Body Control Module (BCM) internally grounds the door unlock relay control circuit for the rear door unlock relay when it receives a Class 2 message from the Driver Door Module (DDM) or Passenger Door Module (PDM). When the BCM grounds the door unlock relay control circuit the rear door unlock relay is energized and unlocks the rear doors.

Conditions for Running the DTC

- Battery voltage is between 9.0-16.0 volts.
- The DTC will set if the rear door unlock function is active or inactive.

Conditions for Setting the DTC

The DTC will set if the door unlock relay control circuit is shorted to ground or open for more than one second.

Action Taken When the DTC Sets

- If a short to ground is present on the door unlock relay control circuit, the door unlock relay will be energized and the rear door lock actuators will be held in the unlock position and will not lock.
- If an open condition is present on the door unlock relay control circuit, the rear doors will lock but not unlock.

Diagnostic Aids

- DTC B3809 could also set if the door unlock relay winding is open.
- If both DTC B3808 and B3809 are set as current, the battery positive voltage circuit or the LOCKS fuse could be open. If the LOCKS fuse is open, the cause is most likely one of the following:
 - A short to ground in the relay battery positive voltage circuit.
 - A short to ground in the door lock actuator lock or unlock control circuits.

Conditions for Clearing the DTC

When the fault is no longer present, the BCM changes the current DTC to a history DTC. The BCM will clear the history DTC after 50 fault free ignition cycles.

Test Description

The numbers below refer to the step numbers on the diagnostic table.

- 2:** Listen for an audible click when the rear door unlock relay operates. Command both the ON and OFF states. Repeat the commands as necessary.
- 3:** Tests for voltage at the coil side of the rear door unlock relay. The LOCKS fuse supplies power to the coil side of the rear door unlock relay.
- 4:** Verifies that the body control module is providing ground to the rear door unlock relay.
- 5:** Tests if ground is constantly being applied to the rear door unlock relay.

DTC B3809

Step	Action	Yes	No
Schematic Reference: <u>Door Lock/Indicator Schematics</u>			
Connector End View Reference: <u>Power Door Systems Connector End Views</u>			
1	Did you perform the Door Systems Diagnostic System Check?		Go to Diagnostic System Check -

		Go to Step 2	<u>Door Systems</u>
2	<ol style="list-style-type: none"> 1. Install a scan tool. 2. With a scan tool, command the rear door unlock relay ON and OFF. <p>Does the rear door unlock relay turn ON and OFF with each command?</p>	<p>Go to Testing for Intermittent Conditions and Poor Connections in Wiring Systems</p>	Go to Step 3
3	<ol style="list-style-type: none"> 1. Remove the rear door unlock relay. 2. Probe the battery positive voltage circuit of the rear door unlock relay with a test lamp that is connected to a good ground. <p>Does the test lamp illuminate?</p>	Go to Step 4	Go to Step 8
4	<ol style="list-style-type: none"> 1. Connect a test lamp between the door unlock relay control circuit and the battery positive voltage circuit of the rear door unlock relay. 2. With a scan tool, command the rear door unlock relay ON and OFF. <p>Does the test lamp turn ON and OFF with each command?</p>	Go to Step 9	Go to Step 5
5	Does the test lamp remain illuminated without being commanded?	Go to Step 7	Go to Step 6
6	Test the door unlock relay control circuit of the rear door unlock relay for an open. Refer to Circuit Testing and Wiring Repairs in Wiring Systems. Did you find and correct the condition?	Go to Step 14	Go to Step 10
7	Test the door unlock relay control circuit of the rear door unlock relay for a short to ground or an open. Refer to Circuit Testing and Wiring Repairs in Wiring Systems. Did you find and correct the condition?	Go to Step 14	Go to Step 10
8	Test for an open or short to ground in the battery positive voltage circuit of the rear door unlock relay. Refer to Wiring Repairs in Wiring Systems. Did you complete the repair?	Go to Step 14	Go to Step 11
9	Inspect for poor connections at the rear door unlock relay. Refer to Testing for Intermittent Conditions and Poor Connections and Connector Repairs in Wiring Systems. Did you find and correct the condition?	Go to Step 14	Go to Step 12
	Inspect for poor connections at the harness connector of the body control module. Refer to Testing for Intermittent Conditions and Poor		

10	Connections and Connector Repairs in Wiring Systems. Did you find and correct the condition?	Go to Step 14	Go to Step 13
11	Repair the short to ground in the door lock actuator lock or unlock control circuits. Refer to Wiring Repairs in Wiring Systems. Did you complete the repair?	Go to Step 14	-
12	Replace the rear door unlock relay. Did you complete the replacement?	Go to Step 14	-
13	IMPORTANT: Perform the set up procedure for the body control module. Replace the body control module. Refer to Body Control Module Replacement in Body Control System. Did you complete the replacement?	Go to Step 14	-
14	1. Use the scan tool in order to clear the DTCs. 2. Operate the vehicle within the Conditions for Running the DTC as specified in the supporting text. Does the DTC reset?	Go to Step 2	System OK

DTC B3819

Circuit Description

The Body Control Module (BCM) grounds the control side of the left rear power window up relay upon receiving a class 2 message from the Driver Door Module (DDM).

Conditions for Running the DTC

- Battery voltage is between 9.0 and 16 volts.
- The BCM has received a class 2 message from the DDM and has grounded the left rear power window relay control circuit.

Conditions for Setting the DTC

- When the BCM has grounded the left rear power window up relay control circuit and the control circuit is shorted to battery positive voltage.
- The above condition is met for 250 milliseconds.

Action Taken When the DTC Sets

The left rear power window will be inoperative from both the driver and left rear power window switches.

Conditions for Clearing the DTC

When the fault is no longer present, the BCM changes the current DTC to a history DTC. The BCM will clear the history DTC after 50 fault free ignition cycles.

Test Description

The numbers below refer to the step numbers on the diagnostic table.

2: Listen for an audible click when the left rear power window relay operates. Command both the ON and OFF states. Repeat the commands as necessary.

3: Tests for voltage at the coil side of the left rear power window up relay.

4: Verifies that the BCM is providing ground to the left rear power window up relay.

5: Tests if ground is constantly being applied to the left rear power window up relay.

DTC B3819

Step	Action	Yes	No
Schematic Reference: Power Window Schematics Connector End View Reference: Power Door Systems Connector End Views			
1	Did you perform the Door Systems Diagnostic System Check?	Go to Step 2	Go to Diagnostic System Check - Door Systems
2	<ol style="list-style-type: none">1. Install a scan tool.2. Turn ON the ignition, with the engine OFF.3. With a scan tool, command the left rear power window up relay ON and OFF. Does the left rear power window up relay turn ON and OFF with each command?	Go to Testing for Intermittent Conditions and Poor Connections in Wiring Systems	Go to Step 3
3	<ol style="list-style-type: none">1. Turn OFF the ignition.2. Disconnect the left rear power window switch.3. Turn ON the ignition, with the engine OFF.4. Probe the battery positive voltage circuit of the left rear power window switch with a test lamp that is connected to a good ground. Does the test lamp illuminate?	Go to Step 4	Go to Step 10
4	<ol style="list-style-type: none">1. Connect a test lamp between the control circuit of the left rear power window up relay and the battery positive voltage circuit of the left rear power window switch.2. With a scan tool, command the left rear		

	power window up relay ON and OFF. Does the test lamp turn ON and OFF with each command?	Go to Step 8	Go to Step 5
5	Does the test lamp remain illuminated with each command?	Go to Step 7	Go to Step 6
6	Test the control circuit of the left rear power window up relay for a short to voltage. Refer to Circuit Testing and Wiring Repairs in Wiring Systems. Did you find and correct the condition?	Go to Step 13	Go to Step 9
7	Test the control circuit of the left rear power window up relay for a short to ground. Refer to Circuit Testing and Wiring Repairs in Wiring Systems. Did you find and correct the condition?	Go to Step 13	Go to Step 9
8	Inspect for poor connections at the left rear power window switch. Refer to Testing for Intermittent Conditions and Poor Connections and Connector Repairs in Wiring Systems. Did you find and correct the condition?	Go to Step 13	Go to Step 11
9	Inspect for poor connections at the harness connector of the Body Control Module. Refer to Testing for Intermittent Conditions and Poor Connections and Connector Repairs in Wiring Systems. Did you find and correct the condition?	Go to Step 13	Go to Step 12
10	Repair the open or short to ground in the battery positive voltage circuit of the left rear power window switch. Refer to Wiring Repairs in Wiring Systems. Did you complete the repair?	Go to Step 13	-
11	Replace the left rear power window switch. Did you complete the replacement?	Go to Step 13	-
12	IMPORTANT: Perform the set up procedure for the Body Control Module. Replace the Body Control Module. Refer to Body Control Module Replacement in Body Control System. Did you complete the replacement?	Go to Step 13	-
13	1. Use the scan tool in order to clear the DTCs. 2. Operate the vehicle within the Conditions for Running the DTC as specified in the supporting text.		

Does the DTC reset?	Go to Step 2	System OK
---------------------	---------------------	-----------

DTC B3820

Circuit Description

The Body Control Module (BCM) grounds the control side of the left rear power window down relay upon receiving a class 2 message from the Driver Door Module (DDM).

Conditions for Running the DTC

- Battery voltage is between 9.0 and 16 volts.
- The BCM has received a class 2 message from the DDM and has grounded the left rear power window down relay control circuit.

Conditions for Setting the DTC

- When the BCM has grounded the left rear power window down relay control circuit and the control circuit is shorted to battery positive voltage.
- The above condition is met for 250 milliseconds.

Action Taken When the DTC Sets

The left rear power window will be inoperative from both the driver and left rear power window switches.

Conditions for Clearing the DTC

When the fault is no longer present, the BCM changes the current DTC to a history DTC. The BCM will clear the history DTC after 50 fault free ignition cycles.

Test Description

The numbers below refer to the step numbers on the diagnostic table.

- 2:** Listen for an audible click when the left rear power window relay operates. Command both the ON and OFF states. Repeat the commands as necessary.
- 3:** Tests for voltage at the coil side of the left rear power window down relay.
- 4:** Verifies that the BCM is providing ground to the left rear power window down relay.
- 5:** Tests if ground is constantly being applied to the left rear power window down relay.

DTC B3820

Step	Action	Yes	No
Schematic Reference: <u>Power Window Schematics</u>			
Connector End View Reference: <u>Power Door Systems Connector End Views</u>			

1	Did you perform the Door Systems Diagnostic System Check?	Go to Step 2	Go to <u>Diagnostic System Check - Door Systems</u>
2	<ol style="list-style-type: none"> 1. Install a scan tool. 2. Turn ON the ignition, with the engine OFF. 3. With a scan tool, command the left rear power window down relay ON and OFF. <p>Does the left rear power window up relay turn ON and OFF with each command?</p>	Go to <u>Testing for Intermittent Conditions and Poor Connections</u> in Wiring Systems	Go to Step 3
3	<ol style="list-style-type: none"> 1. Turn OFF the ignition. 2. Disconnect the left rear power window switch. 3. Turn ON the ignition, with the engine OFF. 4. Probe the battery positive voltage circuit of the left rear power window switch with a test lamp that is connected to a good ground. <p>Does the test lamp illuminate?</p>	Go to Step 4	Go to Step 10
4	<ol style="list-style-type: none"> 1. Connect a test lamp between the control circuit of the left rear power window down relay and the battery positive voltage circuit of the left rear power window switch. 2. With a scan tool, command the left rear power window down relay ON and OFF. <p>Does the test lamp turn ON and OFF with each command?</p>	Go to Step 8	Go to Step 5
5	Does the test lamp remain illuminated with each command?	Go to Step 7	Go to Step 6
6	Test the control circuit of the left rear power window down relay for a short to voltage. Refer to <u>Circuit Testing</u> and <u>Wiring Repairs</u> in Wiring Systems. Did you find and correct the condition?	Go to Step 13	Go to Step 9
7	Test the control circuit of the left rear power window down relay for a short to ground. Refer to <u>Circuit Testing</u> and <u>Wiring Repairs</u> in Wiring Systems. Did you find and correct the condition?	Go to Step 13	Go to Step 9
8	Inspect for poor connections at the left rear power window switch. Refer to <u>Testing for Intermittent Conditions and Poor Connections</u> and <u>Connector</u>		

	Repairs in Wiring Systems. Did you find and correct the condition?	Go to Step 13	Go to Step 11
9	Inspect for poor connections at the harness connector of the Body Control Module. Refer to Testing for Intermittent Conditions and Poor Connections and Connector Repairs in Wiring Systems. Did you find and correct the condition?	Go to Step 13	Go to Step 12
10	Repair the open or short to ground in the battery positive voltage circuit of the left rear power window switch. Refer to Wiring Repairs in Wiring Systems. Did you complete the repair?	Go to Step 13	-
11	Replace the left rear power window switch. Did you complete the replacement?	Go to Step 13	-
12	IMPORTANT: Perform the set up procedure for the Body Control Module. Replace the Body Control Module. Refer to Body Control Module Replacement in Body Control System. Did you complete the replacement?	Go to Step 13	-
13	1. Use the scan tool in order to clear the DTCs. 2. Operate the vehicle within the Conditions for Running the DTC as specified in the supporting text. Does the DTC reset?	Go to Step 2	System OK

DTC B3821

Circuit Description

Battery positive voltage is supplied to the left rear power window switch and the up and down relays through the window lockout signal circuit. If the window lockout function is disabled, the BCM supplies battery positive voltage to the switch and relays and the left rear window operates normally. If the window lockout function is enabled, the BCM will not supply battery positive voltage to the switch and relays and the left rear window will be inoperative unless it is operated from the driver power window switch.

Conditions for Running the DTC

- Battery voltage is between 9.0 and 16.0 volts.
- The window lockout function is disabled

Conditions for Setting the DTC

- The window lockout function is disabled and the window lockout signal circuit is shorted to ground.
- The above condition must be met for 250 milliseconds.

Action Taken When the DTC Sets

The left rear power window will be inoperative from both the driver and passenger power window switches.

Conditions for Clearing the DTC

When the fault is no longer present, the BCM changes the current DTC to a history DTC. The BCM will clear the history DTC after 50 fault free ignition cycles.

DTC B3821

Step	Action	Yes	No
Schematic Reference: Power Window Schematics			
Connector End View Reference: Power Door Systems Connector End Views			
1	Did you perform the Door Systems Diagnostic System Check?	Go to Step 2	Go to <u>Diagnostic System Check - Door Systems</u>
2	<ol style="list-style-type: none"> 1. Install a scan tool. 2. Turn ON the ignition, with the engine OFF. 3. Disable the window lockout function. 4. With a scan tool, command the left rear power window UP and DOWN. <p>Does the left rear power window operate UP and DOWN with each command?</p>	Go to <u>Testing for Intermittent Conditions and Poor Connections</u> in Wiring Systems	Go to Step 3
3	<ol style="list-style-type: none"> 1. Turn OFF the ignition. 2. Disconnect the left rear power window switch. 3. Turn ON the ignition, with the engine OFF. 4. Ensure the window lockout function is disabled. 5. Probe the window lockout signal circuit with a test lamp connected to a good ground. <p>Does the test lamp illuminate?</p>	Go to <u>Testing for Intermittent Conditions and Poor Connections</u> in Wiring Systems	Go to Step 4
4	<p>Test the window lockout signal circuit for a short to ground. Refer to <u>Circuit Testing</u> and <u>Wiring Repairs</u> in Wiring Systems.</p> <p>Did you find and correct the condition?</p>	Go to Step 7	Go to Step 5
	Inspect for poor connections at the harness connector of the Body Control Module. Refer to		

5	<p>Testing for Intermittent Conditions and Poor Connections and Connector Repairs in Wiring Systems.</p> <p>Did you find and correct the condition?</p>	Go to Step 7	Go to Step 6
6	<p>IMPORTANT: Perform the set up procedure for the Body Control Module.</p> <p>Replace the Body Control Module. Refer to Body Control Module Replacement in Body Control System. Did you complete the replacement?</p>	Go to Step 7	-
7	<ol style="list-style-type: none"> 1. Use the scan tool in order to clear the DTCs. 2. Operate the vehicle within the Conditions for Running the DTC as specified in the supporting text. <p>Does the DTC reset?</p>	Go to Step 2	System OK

DTC B3822

Circuit Description

The Body Control Module (BCM) grounds the control side of the right rear power window up relay upon receiving a class 2 message from the Driver Door Module (DDM).

Conditions for Running the DTC

- Battery voltage is between 9.0 and 16 volts.
- The BCM has received a class 2 message from the DDM and has grounded the right rear power window relay control circuit.

Conditions for Setting the DTC

- When the BCM has grounded the right rear power window up relay control circuit and the control circuit is shorted to battery positive voltage.
- The above condition is met for 250 milliseconds.

Action Taken When the DTC Sets

The right rear power window will be inoperative from both the driver and right rear power window switches.

Conditions for Clearing the DTC

When the fault is no longer present, the BCM changes the current DTC to a history DTC. The BCM will clear the history DTC after 50 fault free ignition cycles.

Test Description

The numbers below refer to the step numbers on the diagnostic table.

2: Listen for an audible click when the right rear power window relay operates. Command both the ON and OFF states. Repeat the commands as necessary.

3: Tests for voltage at the coil side of the right rear power window up relay.

4: Verifies that the BCM is providing ground to the right rear power window up relay.

5: Tests if ground is constantly being applied to the right rear power window up relay.

DTC B3822

Step	Action	Yes	No
Schematic Reference: <u>Power Window Schematics</u> Connector End View Reference: <u>Power Door Systems Connector End Views</u>			
1	Did you perform the Door Systems Diagnostic System Check?	Go to Step 2	Go to <u>Diagnostic System Check - Door Systems</u>
2	<ol style="list-style-type: none">1. Install a scan tool.2. Turn ON the ignition, with the engine OFF.3. With a scan tool, command the right rear power window up relay ON and OFF. Does the right rear power window up relay turn ON and OFF with each command?	Go to <u>Testing for Intermittent Conditions and Poor Connections</u> in Wiring Systems	Go to Step 3
3	<ol style="list-style-type: none">1. Turn OFF the ignition.2. Disconnect the right rear power window switch.3. Turn ON the ignition, with the engine OFF.4. Probe the battery positive voltage circuit of the right rear power window switch with a test lamp that is connected to a good ground. Does the test lamp illuminate?	Go to Step 4	Go to Step 10
4	<ol style="list-style-type: none">1. Connect a test lamp between the control circuit of the right rear power window up relay and the battery positive voltage circuit of the right rear power window switch.2. With a scan tool, command the right rear power window up relay ON and OFF. Does the test lamp turn ON and OFF with each command?	Go to Step 8	Go to Step 5
	Does the test lamp remain illuminated with each		

5	command?	Go to Step 7	Go to Step 6
6	Test the control circuit of the right rear power window up relay for a short to voltage. Refer to Circuit Testing and Wiring Repairs in Wiring Systems. Did you find and correct the condition?	Go to Step 13	Go to Step 9
7	Test the control circuit of the right rear power window up relay for a short to ground. Refer to Circuit Testing and Wiring Repairs in Wiring Systems. Did you find and correct the condition?	Go to Step 13	Go to Step 9
8	Inspect for poor connections at the right rear power window switch. Refer to Testing for Intermittent Conditions and Poor Connections and Connector Repairs in Wiring Systems. Did you find and correct the condition?	Go to Step 13	Go to Step 11
9	Inspect for poor connections at the harness connector of the Body Control Module. Refer to Testing for Intermittent Conditions and Poor Connections and Connector Repairs in Wiring Systems. Did you find and correct the condition?	Go to Step 13	Go to Step 12
10	Repair the battery positive voltage circuit of the right rear power window switch. Refer to Wiring Repairs in Wiring Systems. Did you complete the repair?	Go to Step 13	-
11	Replace the right rear power window switch. Did you complete the replacement?	Go to Step 13	-
12	IMPORTANT: Perform the set up procedure for the Body Control Module. Replace the Body Control Module. Refer to Body Control Module Replacement in Body Control System. Did you complete the replacement?	Go to Step 13	-
13	1. Use the scan tool in order to clear the DTCs. 2. Operate the vehicle within the Conditions for Running the DTC as specified in the supporting text. Does the DTC reset?	Go to Step 2	System OK

DTC B3823

Circuit Description

The Body Control Module (BCM) grounds the control side of the right rear power window down relay upon receiving a class 2 message from the Driver Door Module (DDM).

Conditions for Running the DTC

- Battery voltage is between 9.0 and 16 volts.
- The BCM has received a class 2 message from the DDM and has grounded the right rear power window down relay control circuit.

Conditions for Setting the DTC

- When the BCM has grounded the right rear power window down relay control circuit and the control circuit is shorted to battery positive voltage.
- The above condition is met for 250 milliseconds.

Action Taken When the DTC Sets

The right rear power window will be inoperative from both the driver and right rear power window switches.

Conditions for Clearing the DTC

When the fault is no longer present, the BCM changes the current DTC to a history DTC. The BCM will clear the history DTC after 50 fault free ignition cycles.

Test Description

The numbers below refer to the step numbers on the diagnostic table.

- 2:** Listen for an audible click when the right rear power window relay operates. Command both the ON and OFF states. Repeat the commands as necessary.
- 3:** Tests for voltage at the coil side of the right rear power window down relay.
- 4:** Verifies that the BCM is providing ground to the right rear power window down relay.
- 5:** Tests if ground is constantly being applied to the right rear power window down relay.

DTC B3823

Step	Action	Yes	No
Schematic Reference: Power Window Schematics Connector End View Reference: Power Door Systems Connector End Views			
1	Did you perform the Door Systems Diagnostic System Check?	Go to Step 2	Go to Diagnostic System Check - Door Systems
2	1. Install a scan tool. 2. Turn ON the ignition, with the engine OFF. 3. With a scan tool, command the right rear		

	power window down relay ON and OFF. Does the right rear power window down relay turn ON and OFF with each command?	Go to Testing for Intermittent Conditions and Poor Connections in Wiring Systems	Go to Step 3
3	<ol style="list-style-type: none"> 1. Turn OFF the ignition. 2. Disconnect the right rear power window switch. 3. Turn ON the ignition, with the engine OFF. 4. Probe the battery positive voltage circuit of the right rear power window switch with a test lamp that is connected to a good ground. <p>Does the test lamp illuminate?</p>	Go to Step 4	Go to Step 10
4	<ol style="list-style-type: none"> 1. Connect a test lamp between the control circuit of the right rear power window down relay and the battery positive voltage circuit of the right rear power window switch. 2. With a scan tool, command the right rear power window down relay ON and OFF. <p>Does the test lamp turn ON and OFF with each command?</p>	Go to Step 8	Go to Step 5
5	Does the test lamp remain illuminated with each command?	Go to Step 7	Go to Step 6
6	Test the control circuit of the right rear power window down relay for a short to voltage. Refer to Circuit Testing and Wiring Repairs in Wiring Systems. Did you find and correct the condition?	Go to Step 13	Go to Step 9
7	Test the control circuit of the right rear power window down relay for a short to ground. Refer to Circuit Testing and Wiring Repairs in Wiring Systems. Did you find and correct the condition?	Go to Step 13	Go to Step 9
8	Inspect for poor connections at the right rear power window switch. Refer to Testing for Intermittent Conditions and Poor Connections and Connector Repairs in Wiring Systems. Did you find and correct the condition?	Go to Step 13	Go to Step 11
9	Inspect for poor connections at the harness connector of the Body Control Module. Refer to Testing for Intermittent Conditions and Poor Connections and Connector Repairs in Wiring Systems.		

	Did you find and correct the condition?	Go to Step 13	Go to Step 12
10	Repair the battery positive voltage circuit of the right rear power window switch. Refer to Wiring Repairs in Wiring Systems. Did you complete the repair?	Go to Step 13	-
11	Replace the right rear power window switch. Did you complete the replacement?	Go to Step 13	-
12	IMPORTANT: Perform the set up procedure for the Body Control Module. Replace the Body Control Module. Refer to Body Control Module Replacement in Body Control System. Did you complete the replacement?	Go to Step 13	-
13	1. Use the scan tool in order to clear the DTCs. 2. Operate the vehicle within the Conditions for Running the DTC as specified in the supporting text. Does the DTC reset?	Go to Step 2	System OK

DTC B3824

Circuit Description

Battery positive voltage is supplied to the right rear power window switch and the up and down relays through the window lockout signal circuit. If the window lockout function is disabled, the BCM supplies battery positive voltage to the switch and relays and the right window operates normally. If the window lockout function is enabled, the BCM will not supply battery positive voltage to the switch and relays and the right rear window will be inoperative unless it is operated from the driver power window switch.

Conditions for Running the DTC

- Battery voltage is between 9.0 and 16.0 volts
- The window lockout function is disabled

Conditions for Setting the DTC

- The window lockout function is disabled and the window lockout signal circuit is shorted to ground.
- The above condition must be met for 250 milliseconds.

Action Taken When the DTC Sets

The right rear power window will be inoperative from both the driver and passenger power window switches.

Conditions for Clearing the DTC

When the fault is no longer present, the BCM changes the current DTC to a history DTC. The BCM will clear the history DTC after 50 fault free ignition cycles.

DTC B3824

Step	Action	Yes	No
Schematic Reference: Power Window Schematics Connector End View Reference: Power Door Systems Connector End Views			
1	Did you perform the Door Systems Diagnostic System Check?	Go to Step 2	Go to <u>Diagnostic System Check - Door Systems</u>
2	<ol style="list-style-type: none"> 1. Install a scan tool. 2. Turn ON the ignition, with the engine OFF. 3. Disable the window lockout function. 4. With a scan tool, command the right rear power window UP and DOWN. <p>Does the right rear power window operate UP and DOWN with each command?</p>	Go to <u>Testing for Intermittent Conditions and Poor Connections</u> in Wiring Systems	Go to Step 3
3	<ol style="list-style-type: none"> 1. Turn OFF the ignition. 2. Disconnect the right rear power window switch. 3. Turn ON the ignition, with the engine OFF. 4. Ensure the window lockout function is disabled. 5. Probe the window lockout signal circuit with a test lamp connected to a good ground. <p>Does the test lamp illuminate?</p>	Go to <u>Testing for Intermittent Conditions and Poor Connections</u> in Wiring Systems	Go to Step 4
4	<p>Test the window lockout signal circuit for a short to ground. Refer to <u>Circuit Testing</u> and <u>Wiring Repairs</u> in Wiring Systems.</p> <p>Did you find and correct the condition?</p>	Go to Step 7	Go to Step 5
5	<p>Inspect for poor connections at the harness connector of the Body Control Module. Refer to <u>Testing for Intermittent Conditions and Poor Connections</u> and <u>Connector Repairs</u> in Wiring Systems.</p> <p>Did you find and correct the condition?</p>	Go to Step 7	Go to Step 6
	<p>IMPORTANT:</p> <p>Perform the set up procedure for the Body Control Module.</p>		

6	Replace the Body Control Module. Refer to Body Control Module Replacement in Body Control System. Did you complete the replacement?	Go to Step 7	-
7	<ol style="list-style-type: none"> 1. Use the scan tool in order to clear the DTCs. 2. Operate the vehicle within the Conditions for Running the DTC as specified in the supporting text. <p>Does the DTC reset?</p>	Go to Step 2	System OK

DTC B3825

Circuit Description

The body control module (BCM) internally grounds the liftgate lock relay control circuit for the liftgate lock relay when it receives a Class 2 message from the driver door module (DDM), passenger door module (PDM), or when a liftgate lock function is activated. When the BCM grounds the liftgate lock relay control circuit the liftgate lock relay is energized and locks the liftgate.

Conditions for Running the DTC

- Battery voltage is between 9.0-16.0 volts.
- The DTC will set if the liftgate lock function is active or inactive.

Conditions for Setting the DTC

The DTC will set if the liftgate lock relay control circuit is shorted to ground or open for more than one second.

Action Taken When the DTC Sets

- If a short to ground is present on the liftgate lock relay control circuit, the liftgate lock relay will be energized and the liftgate lock actuator will be held in the lock position and will not unlock.
- If an open condition is present on the liftgate lock relay control circuit, the liftgate will unlock but not lock.
- The BCM will send a Class 2 message to the DIC indicating that a fault has been detected and the DIC will display REPLACE LIFTGATE FUSE.

Conditions for Clearing the DTC

When the fault is no longer present, the BCM changes the current DTC to a history DTC. The BCM will clear the history DTC after 50 fault free ignition cycles.

Diagnostic Aids

DTC B3825 will set as current if any of the following conditions are present:

- An open ECC fuse
- An open or short to ground in the liftgate lock relay battery positive voltage circuit
- A faulty liftgate lock relay
- An open or short to ground in the liftgate lock relay control circuit
- A short to ground in the liftgate lock actuator lock control circuit will open the ECC with a lock command
- A faulty BCM

Test Description

The numbers below refer to the step numbers on the diagnostic table.

2: Command both the Lock and Unlock states. Repeat the commands as necessary.

3: Tests for voltage at the coil side of the liftgate lock relay. The ECC fuse supplies power to the coil side of the liftgate lock relay.

4: Verifies that the body control module is providing ground to the liftgate lock relay.

5: Tests if ground is constantly being applied to the liftgate lock relay.

DTC B3825

Step	Action	Yes	No
Schematic Reference: <u>Door Lock/Indicator Schematics</u>			
Connector End View Reference: <u>Power Door Systems Connector End Views</u>			
1	Did you perform the Door Systems Diagnostic System Check?	Go to Step 2	Go to <u>Diagnostic System Check - Door Systems</u>
2	1. Install a scan tool. 2. With a scan tool, command the rear doors to Lock and Unlock. Does the liftgate Lock and Unlock with each command?	Go to <u>Testing for Intermittent Conditions and Poor Connections</u> in Wiring Systems	Go to Step 3
3	1. Remove the liftgate lock relay. 2. Probe the battery positive voltage circuit of the liftgate lock relay with a test lamp that is connected to a good ground. Does the test lamp illuminate?	Go to Step 4	Go to Step 8
4	1. Connect a test lamp between the liftgate lock relay control circuit and the battery positive voltage circuit of the liftgate lock relay. 2. With a scan tool, command the rear doors to Lock and Unlock.		

	Does the test lamp turn ON and OFF with each command?	Go to Step 9	Go to Step 5
5	Does the test lamp remain illuminated without being commanded?	Go to Step 7	Go to Step 6
6	Test the liftgate lock relay control circuit of the liftgate lock relay for an open. Refer to Circuit Testing and Wiring Repairs in Wiring Systems. Did you find and correct the condition?	Go to Step 14	Go to Step 10
7	Test the liftgate lock relay control circuit of the liftgate lock relay for a short to ground or an open. Refer to Circuit Testing and Wiring Repairs in Wiring Systems. Did you find and correct the condition?	Go to Step 14	Go to Step 10
8	Test for an open or short to ground in the battery positive voltage circuit of the liftgate lock relay. Refer to Circuit Testing and Wiring Repairs in Wiring Systems. Did you complete the repair?	Go to Step 14	Go to Step 11
9	Inspect for poor connections at the liftgate lock relay. Refer to Testing for Intermittent Conditions and Poor Connections and Connector Repairs in Wiring Systems. Did you find and correct the condition?	Go to Step 13	Go to Step 12
10	Inspect for poor connections at the harness connector of the body control module (BCM). Refer to Testing for Intermittent Conditions and Poor Connections and Connector Repairs in Wiring Systems. Did you find and correct the condition?	Go to Step 14	Go to Step 13
11	Repair the short to ground in the liftgate lock actuator lock control circuit. Refer to Wiring Repairs in Wiring Systems. Did you complete the repair?	Go to Step 14	-
12	Replace the liftgate lock relay. Did you complete the replacement?	Go to Step 14	-
13	IMPORTANT: Perform the set up procedure for the BCM. Replace the BCM. Refer to Body Control Module Replacement in Body Control System. Did you complete the replacement?	Go to Step 14	-
14	1. Use the scan tool in order to clear the DTCs. 2. Operate the vehicle within the Conditions for Running the DTC as specified in the		

supporting text.		
Does the DTC reset?	Go to Step 2	System OK

SYMPTOMS - DOORS

IMPORTANT: The following steps must be completed before using the symptom tables.

1. Perform the **Diagnostic System Check - Door Systems** before using the Symptom Tables in order to verify that all of the following are true:
 - There are no DTCs set.
 - The control module(s) can communicate via the serial data link.
2. Review the system operation in order to familiarize yourself with the system functions. Refer to the following system descriptions:
 - **Power Windows Description and Operation**
 - **Power Door Locks Description and Operation**
 - **Door Ajar Indicator Description and Operation**
 - **Outside Mirror Description and Operation (Power Mirrors)** or **Outside Mirror Description and Operation (Heated Mirrors)** or **Outside Mirror Description and Operation (Auto Day - Night Mirrors)**

Visual/Physical Inspection

- Inspect for aftermarket devices which could affect the operation of the power door lock, power window and power mirror systems]. Refer to **Checking Aftermarket Accessories** in Wiring Systems.
- Inspect the easily accessible or visible system components for obvious damage or conditions which could cause the symptom.

Intermittent

Faulty electrical connections or wiring may be the cause of intermittent conditions. Refer to **Testing for Intermittent Conditions and Poor Connections** in Wiring Systems.

Symptom List

Refer to a symptom diagnostic procedure from the following list in order to diagnose the symptom:

- **Power Windows Inoperative - Express Down Function**
- **Power Windows Inoperative - Lockout Function**
- **Power Window Inoperative - Driver Door**
- **Power Window Inoperative - Passenger Door (Front Door)** or **Power Window Inoperative - Passenger Door (Rear Door(s))**
- **Door Ajar Indicator Malfunction**

- **Power Door Locks Inoperative (Front Door(s)) or Power Door Locks Inoperative (Rear Door(s))**
- **Power Door Locks Inoperative - Endgate/Liftgate**
- **Power Mirrors Inoperative**
- **Power Mirrors - Folding Inoperative**
- **Power Mirrors - Memory Functions Inoperative**
- **Mirrors - Outside Automatic Day-Night Feature Inoperative**
- **Heated Mirrors Inoperative**

POWER WINDOWS INOPERATIVE - EXPRESS DOWN FUNCTION

Power Windows Inoperative - Express Down Function

Step	Action	Yes	No
Schematic Reference: Power Window Schematics			
Connector End View Reference: Power Door Systems Connector End Views			
1	Did you perform the Door Systems Diagnostic System Check?	Go to Step 2	Go to Diagnostic System Check - Door Systems
2	Activate the power window switch to the express down position and release the power window switch. Does the power window continue to travel downward after the power window switch is released?	Go to Testing for Intermittent Conditions and Poor Connections in Wiring Systems	Go to Step 3
3	1. Install a scan tool. 2. Monitor the appropriate window status data parameter in the driver door input list. 3. Activate the appropriate power window switch to the express down position. Does the window status data parameter change to Express Down?	Go to Step 4	Go to Step 6
4	Is the express down function inoperative on the passenger front power window?	Go to Step 5	Go to Step 6
5	Inspect for poor connections at the passenger door module. Refer to Testing for Intermittent Conditions and Poor Connections and Connector Repairs in Wiring Systems. Did you find and correct the condition?	Go to Step 9	Go to Step 7
6	Inspect for poor connections at the driver door module. Refer to Testing for Intermittent Conditions and Poor Connections and Connector Repairs in Wiring Systems. Did you find and correct the condition?	Go to Step 9	Go to Step 8

7	<p>IMPORTANT: Perform the set up procedure for the passenger door module. Refer to <u>Service Programming System (SPS) in Programming</u>.</p> <p>Replace the passenger door module. Refer to <u>Switch Replacement - Door Lock and Side Window - Passenger</u> .Did you complete the repair?</p>	Go to Step 9	-
8	<p>IMPORTANT: Perform the set up procedure for the driver door module. Refer to <u>Service Programming System (SPS) in Programming</u>.</p> <p>Replace the driver door module. Refer to <u>Switch Replacement - Door Lock and Side Window - Driver</u> .Did you complete the repair?</p>	Go to Step 9	-
9	Operate the system in order to verify the repair. Did you correct the condition?	System OK	Go to Step 3

POWER WINDOWS INOPERATIVE - LOCKOUT FUNCTION

Power Windows Inoperative - Lockout Function

Step	Action	Yes	No
Schematic Reference: Power Window Schematics			
Connector End View Reference: Power Door Systems Connector End Views			
1	Did you perform the Door Systems Diagnostic System Check?	Go to Step 2	Go to Diagnostic System Check - Door Systems
2	<ol style="list-style-type: none"> 1. Disable the window lockout function. 2. Operate the passenger power windows from the passenger door power window switches. <p>Do the passenger power windows operate normally?</p>	Go to Step 3	Go to Power Window Inoperative - Passenger Door (Front Door) or Power Window Inoperative - Passenger Door (Rear Door(s))
3	<ol style="list-style-type: none"> 1. Enable the window lockout function. 2. Operate the passenger power windows from the passenger door power window switches. <p>Do the passenger power windows operate up and down?</p>	Go to Step 4	Go to Testing for Intermittent Conditions and Poor Connections in Wiring Systems
	<ol style="list-style-type: none"> 1. Install a scan tool. 2. Monitor the window lockout data parameter in the driver door module input list. 		

4	<p>3. Place the window lockout switch in both the ON and OFF positions.</p> <p>Does the window lockout data parameter change accordingly?</p>	Go to Step 5	Go to Step 10
5	<p>Does the window lockout function for the front passenger power window operate properly?</p>	Go to Step 6	Go to Step 9
6	<p>1. Disable the window lockout function.</p> <p>2. Disconnect the appropriate rear window switch.</p> <p>3. Connect a test lamp to a good ground.</p> <p>4. Probe the rear window lockout signal circuit at the rear window switch harness connector.</p> <p>Does the test lamp illuminate?</p>	Go to Step 7	Go to Step 11
7	<p>Test for a short to battery positive voltage on the rear window lockout signal circuit. Refer to Circuit Testing and Wiring Repairs in Wiring Systems. Did you find and correct the condition?</p>	Go to Step 16	Go to Step 8
8	<p>Inspect for poor connections at the body control module. Refer to Testing for Intermittent Conditions and Poor Connections and Connector Repairs in Wiring Systems. Did you find and correct the condition?</p>	Go to Step 16	Go to Step 12
9	<p>Inspect for poor connections at the passenger door module. Refer to Testing for Intermittent Conditions and Poor Connections and Connector Repairs in Wiring Systems. Did you find and correct the condition?</p>	Go to Step 16	Go to Step 13
10	<p>Inspect for poor connections at the driver door module. Refer to Testing for Intermittent Conditions and Poor Connections and Connector Repairs in Wiring Systems. Did you find and correct the condition?</p>	Go to Step 16	Go to Step 14
11	<p>Inspect for poor connections at the rear power window switch. Refer to Testing for Intermittent Conditions and Poor Connections and Connector Repairs in Wiring Systems. Did you find and correct the condition?</p>	Go to Step 16	Go to Step 15
12	<p>IMPORTANT: Perform the set up procedure for the body control module. Refer to Body Control Module (BCM) Programming/RPO Configuration in Body Control System.</p>		

	Replace the body control module. Refer to Body Control Module Replacement in Body Control System. Did you complete the replacement?	Go to Step 16	-
13	IMPORTANT: Perform the set up procedure for the passenger door module. Refer to Service Programming System (SPS) in Programming. Replace the passenger door module. Refer to Switch Replacement - Door Lock and Side Window - Passenger .Did you complete the repair?	Go to Step 16	-
14	IMPORTANT: Perform the set up procedure for the driver door module. Refer to Service Programming System (SPS) in Programming. Replace the driver door module. Refer to Switch Replacement - Door Lock and Side Window - Driver .Did you complete the repair?	Go to Step 16	-
15	Replace the rear power window switch. Refer to Power Window Switch Replacement - Rear Door . Did you complete the repair?	Go to Step 16	-
16	Operate the system in order to verify the repair. Did you correct the condition?	System OK	Go to Step 2

POWER WINDOW INOPERATIVE - DRIVER DOOR

Power Window Inoperative - Driver Door

Step	Action	Yes	No
Schematic Reference: Power Window Schematics Connector End View Reference: Power Door Systems Connector End Views			
1	Did you perform the Door Systems Diagnostic System Check?	Go to Step 2	Go to Diagnostic System Check - Door Systems
2	Operate the driver power window in the UP and DOWN directions. Does the driver power window operate properly?	Go to Testing for Intermittent Conditions and Poor Connections in Wiring Systems	Go to Step 3
3	1. Install a scan tool. 2. Monitor the driver window status data parameter in the driver door inputs list. Does the driver window status data parameter		

	display an active state?	Go to Step 11	Go to Step 4
4	<ol style="list-style-type: none"> 1. Monitor the driver window status data parameter in the driver door module inputs list. 2. Activate the driver power window switch in the up and down positions. <p>Does the driver window status data parameter change accordingly?</p>	Go to Step 5	Go to Step 11
5	<ol style="list-style-type: none"> 1. Connect a test lamp to a good ground. 2. Backprobe the battery positive voltage circuit at connector C1 cavity 2. <p>Does the test lamp illuminate?</p>	Go to Step 6	Go to Step 13
6	<ol style="list-style-type: none"> 1. Disconnect the driver power window motor. 2. Connect a test lamp to a good ground. 3. Probe the power window motor up control circuit at the power window motor harness connector. 4. Activate the power window switch to the UP position. <p>Does the test illuminate?</p>	Go to Step 7	Go to Step 9
7	<ol style="list-style-type: none"> 1. With the test lamp still connected to a good ground, probe the power window motor down control circuit. 2. Activate the power window switch to the DOWN position. <p>Does the test lamp illuminate?</p>	Go to Step 8	Go to Step 10
8	<ol style="list-style-type: none"> 1. Connect a test lamp between the power window motor up and down control circuits. 2. Activate the power window switch to the UP and DOWN positions. <p>Does the test lamp illuminate in both positions?</p>	Go to Step 12	Go to Step 11
9	<p>Test for an open or short to ground in the power window motor up control circuit. Refer to Circuit Testing and Wiring Repairs in Wiring Systems. Did you find and correct the condition?</p>	Go to Step 16	Go to Step 11
	<p>Test for an open or short to ground in the power window motor down control circuit. Refer to</p>		

10	Circuit Testing and Wiring Repairs in Wiring Systems. Did you find and correct the condition?	Go to Step 16	Go to Step 11
11	Inspect for poor connections at the driver door module. Refer to Testing for Intermittent Conditions and Poor Connections and Connector Repairs in Wiring Systems. Did you find and correct the condition?	Go to Step 16	Go to Step 14
12	Inspect for poor connections at the driver power window motor. Refer to Testing for Intermittent Conditions and Poor Connections and Connector Repairs in Wiring Systems. Did you find and correct the condition?	Go to Step 16	Go to Step 15
13	Repair the open or short to ground in the battery positive voltage circuit. Refer to Wiring Repairs in Wiring Systems. Did you complete the repair?	Go to Step 16	-
14	IMPORTANT: Perform the set up procedure for the driver door module. Refer to Service Programming System (SPS) in Programming. Replace the driver door module. Refer to Switch Replacement - Door Lock and Side Window - Driver .Did you complete the repair?	Go to Step 16	-
15	Replace the driver power window motor. Refer to Window Regulator Motor Replacement - Front Door . Did you complete the repair?	Go to Step 16	-
16	Operate the system in order to verify the repair. Did you correct the condition?	System OK	Go to Step 3

POWER WINDOW INOPERATIVE - PASSENGER DOOR (FRONT DOOR)

Power Window Inoperative - Passenger Door (Front Door)

Step	Action	Yes	No
Schematic Reference: Power Window Schematics			
Connector End View Reference:Power Door Systems Connector End Views			
1	Did you perform the Door Systems Diagnostic System Check?	Go to Step 2	Go to Diagnostic System Check - Door Systems
	<ol style="list-style-type: none"> 1. Turn ON the ignition, with the engine OFF. 2. Disable the window lockout function. 3. Operate the passenger front power window 		

2	<p>in the UP and DOWN directions from the passenger switch.</p> <p>Does the passenger front power window operate properly?</p>	Go to Step 3	Go to Step 4
3	<p>Operate the passenger front power window in the UP and DOWN directions from the master switch.</p> <p>Does the passenger front power window operate properly from the master switch?</p>	Go to Testing for Intermittent Conditions and Poor Connections in Wiring Systems	Go to Step 5
4	<ol style="list-style-type: none"> 1. Install a scan tool. 2. Monitor the window lockout data parameter in the driver door module inputs list. 3. Activate the window lockout switch to both the On and OFF positions. <p>Does the window lockout data parameter change state appropriately?</p>	Go to Step 5	Go to Step 16
5	<p>Monitor the passenger front window status data parameter in both the driver and passenger door module input lists.</p> <p>Do either passenger front window status data parameters display an active state without a window switch activation?</p>	Go to Step 6	Go to Step 7
6	<p>Is the active switch displayed in the driver door module input list?</p>	Go to Step 16	Go to Step 15
7	<ol style="list-style-type: none"> 1. Monitor the passenger front window status in the passenger door module inputs list. 2. Activate the passenger power switch on the passenger door module in the up and down positions. <p>Does the window status data parameter change accordingly?</p>	Go to Step 8	Go to Step 15
8	<ol style="list-style-type: none"> 1. Monitor the passenger front window status in the driver door module inputs list. 2. Activate the passenger front power window switch on the driver door module in the up and down positions. <p>Does the window status data parameter change accordingly?</p>	Go to Step 9	Go to Step 16
	<ol style="list-style-type: none"> 1. Connect a test lamp to a good ground. 2. Backprobe the battery positive voltage 		

9	circuit in connector C1 cavity D at the passenger door module. Does the test lamp illuminate?	Go to Step 10	Go to Step 18
10	<ol style="list-style-type: none"> 1. Disconnect the passenger front power window motor. 2. Connect a test lamp to a good ground. 3. Probe the power window motor up control circuit at the power window motor harness connector. 4. Activate the power window switch to the UP position. Does the test illuminate?	Go to Step 11	Go to Step 13
11	<ol style="list-style-type: none"> 1. With the test lamp still connected to a good ground, probe the power window motor down control circuit. 2. Activate the power window switch to the DOWN position. Does the test lamp illuminate?	Go to Step 12	Go to Step 14
12	<ol style="list-style-type: none"> 1. Connect a test lamp between the power window motor up and down control circuits. 2. Activate the power window switch to the UP and DOWN positions. Does the test lamp illuminate in both positions?	Go to Step 17	Go to Step 15
13	Test for an open or short to ground in the power window motor up control circuit. Refer to Circuit Testing and Wiring Repairs in Wiring Systems. Did you find and correct the condition?	Go to Step 22	Go to Step 15
14	Test for an open or short to ground in the power window motor down control circuit. Refer to Circuit Testing and Wiring Repairs in Wiring Systems. Did you find and correct the condition?	Go to Step 22	Go to Step 15
15	Inspect for poor connections at the passenger door module. Refer to Testing for Intermittent Conditions and Poor Connections and Connector Repairs in Wiring Systems. Did you find and correct the condition?	Go to Step 22	Go to Step 19
16	Inspect for poor connections at the driver door module. Refer to Testing for Intermittent Conditions and Poor Connections and		

	Connector Repairs in Wiring Systems. Did you find and correct the condition?	Go to Step 22	Go to Step 20
17	Inspect for poor connections at the passenger front power window motor. Refer to Testing for Intermittent Conditions and Poor Connections and Connector Repairs in Wiring Systems. Did you find and correct the condition?	Go to Step 22	Go to Step 21
18	Repair the open or short to ground in the battery positive voltage circuit. Refer to Wiring Repairs in Wiring Systems. Did you complete the repair?	Go to Step 22	-
19	IMPORTANT: Perform the set up procedure for the passenger door module. Refer to Service Programming System (SPS) in Programming. Replace the passenger door module. Refer to Switch Replacement - Door Lock and Side Window - Passenger .Did you complete the repair?	Go to Step 22	-
20	IMPORTANT: Perform the set up procedure for the driver door module. Refer to Service Programming System (SPS) in Programming. Replace the driver door module. Refer to Switch Replacement - Door Lock and Side Window - Driver .Did you complete the repair?	Go to Step 22	-
21	Replace the passenger front power window motor. Refer to Window Regulator Motor Replacement - Front Door . Did you complete the repair?	Go to Step 22	-
22	Operate the system in order to verify the repair. Did you correct the condition?	System OK	Go to Step 3

POWER WINDOW INOPERATIVE - PASSENGER DOOR (REAR DOOR(S))

Power Window Inoperative - Passenger Door (Rear Door(s))

Step	Action	Yes	No
Schematic Reference:Power Window Schematics			
Connector End View Reference:Power Door Systems Connector End Views			
1	Did you perform the Door Systems Diagnostic System Check?	Go to Step 2	Go to Diagnostic System Check - Door Systems
	1. Disable the window lockout function.		

2	<p>2. Operate the passenger rear power windows in the UP and DOWN directions from the passenger power window switches.</p> <p>Do the passenger rear power windows operate properly?</p>	Go to Step 3	Go to Step 4
3	<p>Operate the passenger rear power windows in the UP and DOWN directions from the master switches.</p> <p>Do the passenger rear power windows operate properly from the master switches?</p>	Go to <u>Testing for Intermittent Conditions and Poor Connections</u> in Wiring Systems	Go to Step 6
4	<p>Are both rear power windows inoperative?</p>	Go to Step 5	Go to Step 9
5	<p>1. Install a scan tool.</p> <p>2. Monitor the window lockout data parameter in the driver door module input list.</p> <p>3. Place the window lockout switch in both the ON and OFF positions.</p> <p>Does the window lockout data parameter change accordingly?</p>	Go to Step 23	Go to Step 24
6	<p>1. Install a scan tool.</p> <p>2. Monitor the rear window status data parameters in the driver door module inputs list.</p> <p>Do either of the rear window status data parameters display an active state without a rear window switch activation?</p>	Go to Step 24	Go to Step 7
7	<p>1. Install a scan tool.</p> <p>2. Monitor the rear window status data parameters in the driver door module inputs list.</p> <p>3. Activate the passenger rear power window switches on the master switch in the up and down positions.</p> <p>Do the rear window status data parameters change accordingly?</p>	Go to Step 8	Go to Step 24
8	<p>1. With a scan tool, monitor the passenger rear window status data parameters in the body control module data list.</p> <p>2. Activate the passenger rear power window switches on the master switch in the up and</p>		

	<p>down positions.</p> <p>Do the rear window status data parameters change accordingly?</p>	Go to Step 16	Go to Step 23
9	<ol style="list-style-type: none"> 1. Disable the window lockout function. 2. Disconnect the inoperative rear window switch. 3. Connect a test lamp to a good ground. 4. Probe the window lockout signal circuit at the rear window switch harness connector. <p>Does the test lamp illuminate?</p>	Go to Step 10	Go to Step 18
10	<p>With a test lamp connected to a good ground, probe the battery positive voltage circuit at the rear power window switch harness connector.</p> <p>Does the test lamp illuminate?</p>	Go to Step 11	Go to Step 27
11	<ol style="list-style-type: none"> 1. Connect a test lamp to battery positive voltage. 2. Probe the ground circuit at the rear power window switch harness connector. <p>Does the test lamp illuminate?</p>	Go to Step 13	Go to Step 28
12	<p>Probe the power window up and down signal circuits one at a time, with a test lamp that is connected to the battery positive voltage.</p> <p>Does the test lamp illuminate at either signal circuit?</p>	Go to Step 19	Go to Step 13
13	<ol style="list-style-type: none"> 1. Disconnect the appropriate rear power window motor. 2. Connect the rear power window switch. 3. Connect a test lamp to a good ground. 4. Probe the power window motor up control circuit at the power window motor harness connector. 5. Activate the power window switch to the UP position. <p>Does the test illuminate?</p>	Go to Step 14	Go to Step 21
14	<ol style="list-style-type: none"> 1. With the test lamp still connected to a good ground, probe the power window motor down control circuit. 2. Activate the power window switch to the 		

	DOWN position.		
	Does the test lamp illuminate?	Go to Step 15	Go to Step 22
15	<ol style="list-style-type: none"> 1. Connect a test lamp between the power window motor up and down control circuits. 2. Activate the power window switch to the UP and DOWN positions. 		
	Does the test lamp illuminate in both positions?	Go to Step 26	Go to Step 25
16	<ol style="list-style-type: none"> 1. Disconnect the appropriate rear power window switch. 2. With a test lamp connected to battery positive voltage, probe the power window up signal circuit at the rear window switch harness connector. 3. Activate the appropriate rear window switch on the master switch to the UP position. 		
	Does the test lamp illuminate?	Go to Step 17	Go to Step 19
17	<ol style="list-style-type: none"> 1. With a test lamp connected to battery positive voltage, probe the power window down signal circuit at the rear window switch harness connector. 2. Activate the appropriate rear window switch on the master switch to the DOWN position. 		
	Does the test lamp illuminate?	Go to Step 25	Go to Step 20
18	<p>Test for an open in the window lockout signal circuit. Refer to Circuit Testing and Wiring Repairs in Wiring Systems.</p> <p>Did you find and correct the condition?</p>	Go to Step 33	Go to Step 23
19	<p>Test for an open or short to ground in the power window up or down signal circuit. Refer to Circuit Testing and Wiring Repairs in Wiring Systems.</p> <p>Did you find and correct the condition?</p>	Go to Step 33	Go to Step 23
20	<p>Test for an open or short to ground in the power window up or down signal circuit. Refer to Circuit Testing and Wiring Repairs in Wiring Systems.</p> <p>Did you find and correct the condition?</p>	Go to Step 33	Go to Step 23
21	<p>Test for an open or short to ground in the power window motor up control circuit. Refer to Circuit Testing and Wiring Repairs in Wiring Systems.</p> <p>Did you find and correct the condition?</p>	Go to Step 33	Go to Step 25
	Test for an open or short to ground in the power		

22	<p>window motor down control circuit. Refer to <u>Circuit Testing</u> and <u>Wiring Repairs</u> in Wiring Systems.</p> <p>Did you find and correct the condition?</p>	Go to Step 33	Go to Step 25
23	<p>Inspect for poor connections at the body control module (BCM). Refer to <u>Testing for Intermittent Conditions and Poor Connections</u> and <u>Connector Repairs</u> in Wiring Systems.</p> <p>Did you find and correct the condition?</p>	Go to Step 33	Go to Step 29
24	<p>Inspect for poor connections at the driver door module. Refer to <u>Testing for Intermittent Conditions and Poor Connections</u> and <u>Connector Repairs</u> in Wiring Systems.</p> <p>Did you find and correct the condition?</p>	Go to Step 33	Go to Step 30
25	<p>Inspect for poor connections at the passenger rear power window switch. Refer to <u>Testing for Intermittent Conditions and Poor Connections</u> and <u>Connector Repairs</u> in Wiring Systems.</p> <p>Did you find and correct the condition?</p>	Go to Step 33	Go to Step 31
26	<p>Inspect for poor connections at the passenger rear power window motor. Refer to <u>Testing for Intermittent Conditions and Poor Connections</u> and <u>Connector Repairs</u> in Wiring Systems.</p> <p>Did you find and correct the condition?</p>	Go to Step 33	Go to Step 32
27	<p>Repair the open or short to ground in the battery positive voltage circuit. Refer to <u>Circuit Testing</u> and <u>Wiring Repairs</u> in Wiring Systems.</p> <p>Did you complete the repair?</p>	Go to Step 33	-
28	<p>Repair the open in the rear power window switch ground circuit. Refer to <u>Circuit Testing</u> and <u>Wiring Repairs</u> in Wiring Systems.</p> <p>Did you complete the repair?</p>	Go to Step 33	-
29	<p>IMPORTANT: Perform the set up procedure for the BCM. Refer to <u>Body Control Module (BCM) Programming/RPO Configuration</u> in Body Control System.</p> <p>Replace the BCM. Refer to <u>Body Control Module Replacement</u> in Body Control System. Did you complete the repair?</p>	Go to Step 33	-
30	<p>IMPORTANT: Perform the set up procedure for the driver door module. Refer to <u>Service Programming System (SPS)</u> in Programming.</p>		

	Replace the driver door module. Refer to <u>Switch Replacement - Door Lock and Side Window - Driver</u> .Did you complete the repair?	Go to Step 33	-
31	Replace the passenger rear power window switch. Refer to <u>Power Window Switch Replacement - Rear Door</u> . Did you complete the repair?	Go to Step 33	-
32	Replace the passenger rear power window motor. Refer to <u>Window Regulator Motor Replacement - Rear Door</u> . Did you complete the repair?	Go to Step 33	-
33	Operate the system in order to verify the repair. Did you correct the condition?	System OK	Go to Step 2

DOOR AJAR INDICATOR MALFUNCTION

Door Ajar Indicator Malfunction

Step	Action	Yes	No
Schematic Reference: <u>Door Lock/Indicator Schematics</u>			
Connector End View Reference: <u>Power Door Systems Connector End Views</u>			
1	Did you perform the Door Systems Diagnostic System Check?	Go to Step 2	Go to <u>Diagnostic System Check - Door Systems</u>
2	Open and close the driver and passenger doors one at a time while monitoring the DIC display. Do the door ajar indicators operate properly?	Go to <u>Testing for Intermittent Conditions and Poor Connections</u> in Wiring Systems	Go to Step 3
3	Do the courtesy lamps operate properly with the opening and closing of each of the doors?	Go to Step 4	Go to <u>Courtesy Lamps Inoperative</u> in Lighting Systems
4	IMPORTANT: Perform the setup procedure for the instrument panel cluster. Replace the instrument panel cluster. Refer to <u>Instrument Panel Cluster (IPC) Replacement</u> in Instrument Panel, Gauges and Console. Did you complete the replacement?	Go to Step 5	-
5	Operate the system in order to verify the repair. Did you correct the condition?	System OK	Go to Step 3

POWER DOOR LOCKS INOPERATIVE (FRONT DOOR(S))

Power Door Locks Inoperative (Front Door(s))

Step	Action	Yes	No
------	--------	-----	----

Schematic Reference: Door Lock/Indicator Schematics**Connector End View Reference: Power Door Systems Connector End Views**

1	Did you perform the Door Systems Diagnostic System Check?	Go to Step 2	Go to <u>Diagnostic System Check - Door Systems</u>
2	Activate the door lock switches to the lock and unlock positions. Do the driver and front passenger doors lock and unlock?	Go to <u>Testing for Intermittent Conditions and Poor Connections</u> in Wiring Systems	Go to Step 3
3	Do the door lock switches lock and unlock at least one of the front door lock actuators?	Go to Step 4	Go to Step 9
4	<ol style="list-style-type: none">1. Disconnect the inoperative door lock actuator.2. With a test lamp connected to a good ground, probe the door lock actuator lock circuit at the door lock actuator harness connector.3. Activate a door lock switch to lock position. Does the test lamp illuminate?	Go to Step 5	Go to Step 7
5	<ol style="list-style-type: none">1. With a test lamp connected to a good ground, probe the door lock actuator unlock circuit at the door lock actuator harness connector.2. Activate a door lock switch to unlock position. Does the test lamp illuminate?	Go to Step 6	Go to Step 8
6	<ol style="list-style-type: none">1. Connect a test lamp between the door lock actuator lock and unlock circuits at the door lock actuator harness connector.2. Activate a door lock switch to both the lock and unlock positions. Does the test lamp illuminate in both positions?	Go to Step 10	Go to Step 9
7	Test for an open or short to ground in the door lock actuator lock circuit. Refer to <u>Circuit Testing</u> and <u>Wiring Repairs</u> in Wiring Systems. Did you find and correct the condition?	Go to Step 13	Go to Step 9
8	Test for an open or short to ground in the door lock actuator unlock circuit. Refer to <u>Circuit Testing</u> and <u>Wiring Repairs</u> in Wiring Systems. Did you find and correct the condition?	Go to Step 13	Go to Step 9
9	Inspect for poor connections at the harness connector of the appropriate door module. Refer to <u>Testing for Intermittent Conditions and Poor Connections</u> and <u>Connector Repairs</u> in Wiring Systems.		

	Did you find and correct the condition?	Go to Step 13	Go to Step 11
10	Inspect for poor connections at the harness connector of the door lock actuator. Refer to Testing for Intermittent Conditions and Poor Connections and Connector Repairs in Wiring Systems. Did you find and correct the condition?	Go to Step 13	Go to Step 12
11	IMPORTANT: Perform the set up procedure for the door module. Refer to Service Programming System (SPS) in Programming. Replace the appropriate door module. Refer to Switch Replacement - Door Lock and Side Window - Driver or Switch Replacement - Door Lock and Side Window - Passenger .Did you complete the repair?	Go to Step 13	-
12	Replace the appropriate door lock actuator. Refer to Latch Replacement - Front Door . Did you complete the repair?	Go to Step 13	-
13	Operate the system in order to verify the repair. Did you correct the condition?	System OK	Go to Step 2

POWER DOOR LOCKS INOPERATIVE (REAR DOOR(S))

Power Door Locks Inoperative (Rear Door(s))

Step	Action	Yes	No
Schematic Reference: <u>Door Lock/Indicator Schematics</u> Connector End View Reference: <u>Power Door Systems Connector End Views</u>			
1	Did you perform the Door Systems Diagnostic System Check?	Go to Step 2	Go to Diagnostic System Check - Door Systems
2	Activate the front door lock switches to the lock and unlock positions. Do both rear passenger doors lock and unlock?	Go to Testing for Intermittent Conditions and Poor Connections in Wiring Systems	Go to Step 3
3	Is there only one door lock actuator that is inoperative?	Go to Power Door Locks Inoperative - One Door or Switch	Go to Step 4
4	Are the rear door lock actuators inoperative for both lock and unlock?	Go to Step 6	Go to Step 5
5	Do the rear door lock actuators lock?	Go to Step 17	Go to Step 12
6	Is the LOCKS fuse open?	Go to Step 24	Go to Step 7
	1. Remove the door unlock relay.		

7	<ol style="list-style-type: none"> 2. Connect a test lamp to a good ground. 3. Probe the door unlock relay coil battery supply voltage circuit. <p>Does the test lamp illuminate?</p>	Go to Step 8	Go to Step 27
8	<ol style="list-style-type: none"> 1. Connect a test lamp to battery positive voltage. 2. Probe the door actuator unlock control circuit cavity in the fuse block. <p>Does the test lamp illuminate?</p>	Go to Step 10	Go to Step 9
9	<ol style="list-style-type: none"> 1. Install the rear door unlock relay. 2. Remove the rear door lock relay. 3. Connect a test lamp to battery positive voltage. 4. Probe the door lock actuator lock control circuit cavity in the fuse block. <p>Does the test lamp illuminate?</p>	Go to Step 11	Go to Step 27
10	<ol style="list-style-type: none"> 1. Connect a test lamp to battery positive voltage. 2. Probe the rear door unlock relay control circuit. <p>Does the test lamp illuminate?</p>	Go to Step 22	Go to Step 26
11	<ol style="list-style-type: none"> 1. Connect a test lamp to battery positive voltage. 2. Probe the rear door lock relay control circuit. <p>Does the test lamp illuminate?</p>	Go to Step 23	Go to Step 25
12	<ol style="list-style-type: none"> 1. Remove the rear door lock relay. 2. Connect a test lamp to a good ground. 3. Probe the battery positive voltage circuit (high current) cavity in the fuse block. <p>Does the test lamp illuminate?</p>	Go to Step 13	Go to Step 27
13	<p>With the test lamp connected to a good ground, probe the lock relay control circuit cavity in the fuse block.</p> <p>Does the test lamp illuminate?</p>	Go to Step 22	Go to Step 14
	<ol style="list-style-type: none"> 1. Connect a test lamp to battery positive 		

14	<p>voltage.</p> <ol style="list-style-type: none"> 2. Probe the lock relay control circuit cavity in the rear fuse block. 3. Activate a door lock switch to the lock position. <p>Does the test lamp illuminate?</p>	Go to Step 15	Go to Step 22
15	<p>With the test lamp connected to battery positive voltage, probe the door lock actuator lock control circuit cavity in the fuse block.</p> <p>Does the test lamp illuminate?</p>	Go to Step 25	Go to Step 16
16	<ol style="list-style-type: none"> 1. Remove the rear door unlock relay. 2. With the test lamp connected to battery positive voltage, probe the unlock relay ground circuit cavity in the fuse block. <p>Does the test lamp illuminate?</p>	Go to Step 26	Go to Step 27
17	<ol style="list-style-type: none"> 1. Remove the rear door unlock relay. 2. Connect a test lamp to a good ground. 3. Probe the battery positive voltage circuit (high current) cavity in the fuse block. <p>Does the test lamp illuminate?</p>	Go to Step 18	Go to Step 27
18	<p>With the test lamp connected to a good ground, probe the unlock relay control circuit cavity in the fuse block.</p> <p>Does the test lamp illuminate?</p>	Go to Step 23	Go to Step 19
19	<ol style="list-style-type: none"> 1. Connect a test lamp to battery positive voltage. 2. Probe the unlock relay control circuit cavity in the fuse block. 3. Activate a door lock switch to the unlock position. <p>Does the test lamp illuminate?</p>	Go to Step 20	Go to Step 23
20	<p>With the test lamp connected to battery positive voltage, probe the door lock actuator unlock control circuit cavity in the rear fuse block.</p> <p>Does the test lamp illuminate?</p>	Go to Step 25	Go to Step 21
21	<ol style="list-style-type: none"> 1. Remove the rear door lock relay. 2. With the test lamp connected to battery positive voltage, probe the lock relay ground 		

	<p>circuit cavity in the rear fuse block.</p> <p>Does the test lamp illuminate?</p>	Go to Step 25	Go to Step 27
22	<p>Test for an open short to ground or short to battery in the door lock relay lock control circuit. Refer to Circuit Testing and Wiring Repairs in Wiring Systems.</p> <p>Did you find and correct the condition?</p>	Go to Step 33	Go to Step 28
23	<p>Test for an open short to ground or short to battery in the door unlock relay lock control circuit. Refer to Circuit Testing and Wiring Repairs in Wiring Systems.</p> <p>Did you find and correct the condition?</p>	Go to Step 33	Go to Step 28
24	<p>Test for a short to ground in the door lock actuator lock and unlock control circuits. Refer to Circuit Testing and Wiring Repairs in Wiring Systems.</p> <p>Did you find and correct the condition?</p>	Go to Step 33	Go to Step 27
25	<p>Inspect for poor connections at the rear door lock relay. Refer to Testing for Intermittent Conditions and Poor Connections and Connector Repairs in Wiring Systems.</p> <p>Did you find and correct the condition?</p>	Go to Step 33	Go to Step 29
26	<p>Inspect for poor connections at the rear door unlock relay. Refer to Testing for Intermittent Conditions and Poor Connections and Connector Repairs in Wiring Systems.</p> <p>Did you find and correct the condition?</p>	Go to Step 33	Go to Step 30
27	<p>Inspect for poor connections at the fuse block. Refer to Testing for Intermittent Conditions and Poor Connections and Connector Repairs in Wiring Systems.</p> <p>Did you find and correct the condition?</p>	Go to Step 33	Go to Step 31
28	<p>Inspect for poor connections at the harness connector of the body control module. Refer to Testing for Intermittent Conditions and Poor Connections and Connector Repairs in Wiring Systems.</p> <p>Did you find and correct the condition?</p>	Go to Step 33	Go to Step 32
29	<p>Replace the rear door lock relay.</p> <p>Did you complete the repair?</p>	Go to Step 33	-
30	<p>Replace the rear door unlock relay.</p> <p>Did you complete the repair?</p>	Go to Step 33	-
31	<p>Replace the rear fuse block.</p> <p>Did you complete the repair?</p>	Go to Step 33	-

32	Replace the BCM. Refer to Body Control Module Replacement in Body Control System. Did you complete the repair?	Go to Step 33	-
33	Operate the system in order to verify the repair. Did you correct the condition?	System OK	Go to Step 2

POWER DOOR LOCKS INOPERATIVE - ONE DOOR OR SWITCH

Power Door Locks Inoperative - One Door or Switch

Step	Action	Yes	No
Schematic Reference: Door Lock/Indicator Schematics Connector End View Reference: Power Door Systems Connector End Views DEFINITION: This diagnostic table should be used to diagnose a failure of the rear door lock switch or one rear door lock actuator.			
1	Did you perform the Door Systems Diagnostic System Check?	Go to Step 2	Go to Diagnostic System Check - Door Systems
2	Activate the rear door lock switch to the lock and unlock positions. Do both rear passenger doors lock and unlock?	Go to Testing for Intermittent Conditions and Poor Connections in Wiring Systems	Go to Step 3
3	1. Install a scan tool. 2. Monitor the rear door lock switch data parameter in the BCM data list. Is the data parameter active without a switch activation?	Go to Step 5	Go to Step 4
4	1. With the scan tool, monitor the rear door lock switch data parameter in the BCM data list. 2. Activate the door lock switch to both the lock and unlock positions. Does the data parameter change with each switch activation?	Go to Step 7	Go to Step 6
5	Disconnect the rear door lock switch. Does the data parameter now display an inactive state?	Go to Step 10	Go to Step 9
6	1. Disconnect the rear door lock switch. 2. Connect a test lamp to ground. 3. Probe the rear door lock switch ground circuit. Does the test lamp illuminate?	Go to Step 9	Go to Step 13
	1. Disconnect the inoperative door lock actuator.		

7	<ol style="list-style-type: none"> 2. With a test lamp connected to a good ground, probe the door lock actuator lock circuit at the door lock actuator harness connector. 3. Activate a door lock switch to lock position. <p>Does the test lamp illuminate?</p>	Go to Step 8	Go to Step 14
8	<ol style="list-style-type: none"> 1. With a test lamp connected to a good ground, probe the door lock actuator unlock circuit at the door lock actuator harness connector. 2. Activate a door lock switch to unlock position. <p>Does the test lamp illuminate?</p>	Go to Step 12	Go to Step 15
9	<p>Test for an open or short to ground in the door lock switch lock and unlock signal circuits. Refer to Circuit Testing and Wiring Repairs in Wiring Systems.</p> <p>Did you find and correct the condition?</p>	Go to Step 19	Go to Step 11
10	<p>Inspect for poor connections at the harness connector of the rear door lock switch. Refer to Testing for Intermittent Conditions and Poor Connections and Connector Repairs in Wiring Systems.</p> <p>Did you find and correct the condition?</p>	Go to Step 19	Go to Step 16
11	<p>Inspect for poor connections at the harness connector of the body control module. Refer to Testing for Intermittent Conditions and Poor Connections and Connector Repairs in Wiring Systems.</p> <p>Did you find and correct the condition?</p>	Go to Step 19	Go to Step 17
12	<p>Inspect for poor connections at the harness connector of the door lock actuator. Refer to Testing for Intermittent Conditions and Poor Connections and Connector Repairs in Wiring Systems.</p> <p>Did you find and correct the condition?</p>	Go to Step 19	Go to Step 18
13	<p>Repair the open in the rear door lock switch ground circuit. Refer to Wiring Repairs in Wiring Systems.</p> <p>Did you complete the repair?</p>	Go to Step 19	-
14	<p>Repair the open the door lock actuator lock circuit. Refer to Wiring Repairs in Wiring Systems.</p> <p>Did you find and correct the condition?</p>	Go to Step 19	-
15	<p>Repair the open in the door lock actuator unlock circuit. Refer to Wiring Repairs in Wiring Systems.</p> <p>Did you find and correct the condition?</p>	Go to Step 19	-
	<p>Replace the rear door lock switch.</p>		

16	Did you complete the repair?	Go to Step 19	-
17	<p>IMPORTANT: Perform the set procedure for the BCM. Refer to <u>Body Control Module (BCM) Programming/RPO Configuration in Body Control System.</u></p> <p>Replace the BCM. Refer to <u>Body Control Module Replacement</u> in Body Control System. Did you complete the repair?</p>	Go to Step 19	-
18	<p>Replace the rear door lock actuator. Refer to <u>Latch Replacement - Rear Door</u> .</p> <p>Did you complete the repair?</p>	Go to Step 19	-
19	<p>Operate the system in order to verify the repair.</p> <p>Did you correct the condition?</p>	System OK	Go to Step 2

POWER DOOR LOCKS INOPERATIVE - ENDGATE/LIFTGATE

Power Door Locks Inoperative - Endgate/Liftgate

Step	Action	Yes	No
Schematic Reference: Door Lock/Indicator Schematics			
Connector End View Reference: Power Door Systems Connector End Views			
1	Did you perform the Door Systems Diagnostic System Check?	Go to Step 2	Go to <u>Diagnostic System Check - Door Systems</u>
2	<p>Activate the door lock switches to the lock and unlock positions.</p> <p>Do both rear passenger doors lock and unlock?</p>	Go to Step 3	Go to <u>Power Door Locks Inoperative (Front Door(s)) or Power Door Locks Inoperative (Rear Door(s))</u>
3	Is the liftgate lock actuator inoperative?	Go to Step 4	Go to <u>Testing for Intermittent Conditions and Poor Connections</u> in Wiring Systems
4	<ol style="list-style-type: none"> 1. Disconnect the liftgate lock actuator. 2. With a test lamp connected to a good ground, probe the lock actuator lock circuit at the lock actuator harness connector. 3. Activate a door lock switch to lock position. <p>Does the test lamp illuminate?</p>	Go to Step 5	Go to Step 7
5	<ol style="list-style-type: none"> 1. With a test lamp connected to a good ground, probe the lock actuator unlock circuit at the lock actuator harness connector. 2. Activate a door lock switch to unlock position. <p>Does the test lamp illuminate?</p>	Go to Step 6	Go to Step 8

6	Inspect for poor connections at the harness connector of the liftgate lock actuator. Refer to <u>Testing for Intermittent Conditions and Poor Connections</u> and <u>Connector Repairs</u> in Wiring Systems. Did you find and correct the condition?	Go to Step 10	Go to Step 9
7	Repair the open the lock actuator lock circuit. Refer to <u>Circuit Testing</u> and <u>Wiring Repairs</u> in Wiring Systems. Did you find and correct the condition?	Go to Step 10	-
8	Repair the open in the lock actuator unlock circuit. Refer to <u>Circuit Testing</u> and <u>Wiring Repairs</u> in Wiring Systems. Did you find and correct the condition?	Go to Step 10	-
9	Replace the liftgate lock actuator. Refer to <u>Lock Actuator Replacement - Liftgate</u> in Body Rear End. Did you complete the repair?	Go to Step 10	-
10	Operate the system in order to verify the repair. Did you correct the condition?	System OK	Go to Step 2

POWER MIRRORS INOPERATIVE

Power Mirrors Inoperative

Step	Action	Yes	No
Schematic Reference: Outside Mirror Schematics			
Connector End View Reference: Power Door Systems Connector End Views			
1	Did you perform the Door Systems Diagnostic System Check?	Go to Step 2	Go to <u>Diagnostic System Check - Door Systems</u>
2	<ol style="list-style-type: none"> Place the mirror select switch in the left mirror position. Activate the mirror position switch in the UP, DOWN, LEFT and RIGHT directions and note the operation. Place the mirror select switch in the right mirror position. Activate the mirror position switch in the UP, DOWN, LEFT and RIGHT directions and note the operation. Do both power mirrors operate properly?	Go to <u>Testing for Intermittent Conditions and Poor Connections</u> in Wiring Systems	Go to Step 3
	<ol style="list-style-type: none"> Install a scan tool. Monitor the mirror select switch and the mirror switch data parameters. 		

3	<p>3. Activate the mirror select switch to the left and right mirror positions.</p> <p>4. Activate the mirror direction switch to the UP, DOWN, LEFT and RIGHT positions.</p> <p>Do all of the mirror data parameters change properly with the corresponding switch activations?</p>	Go to Step 4	Go to Step 6
4	<p>With the scan tool command the inoperative mirror UP, DOWN, LEFT and RIGHT.</p> <p>Does the mirror move with the corresponding scan tool command?</p>	Go to Step 6	Go to Step 5
5	<p>1. Disconnect the inoperative mirror.</p> <p>2. Connect a test lamp between the appropriate mirror motor control circuits for the inoperative direction(s).</p> <p>3. With a scan tool, command the mirror in the inoperative direction(s).</p> <p>Does the test lamp illuminate with the corresponding scan tool command?</p>	Go to Step 7	Go to Step 8
6	<p>Inspect for poor connections at the driver door module. Refer to Testing for Intermittent Conditions and Poor Connections and Connector Repairs in Wiring Systems.</p> <p>Did you find and correct the condition?</p>	Go to Step 12	Go to Step 9
7	<p>Inspect for poor connections at the power mirror. Refer to Testing for Intermittent Conditions and Poor Connections and Connector Repairs in Wiring Systems.</p> <p>Did you find and correct the condition?</p>	Go to Step 12	Go to Step 10
8	<p>Inspect for poor connections at the appropriate door module. Refer to Testing for Intermittent Conditions and Poor Connections and Connector Repairs in Wiring Systems.</p> <p>Did you find and correct the condition?</p>	Go to Step 12	Go to Step 11
9	<p>IMPORTANT:</p> <p>Perform the set up procedure for the driver door module. Refer to <u>Service Programming System (SPS)</u> in Programming.</p> <p>Replace the driver door module. Refer to Switch Replacement - Door Lock and Side Window - Driver .Did you complete the repair?</p>	Go to Step 12	-
	<p>Replace the power mirror. Refer to Mirror</p>		

10	Replacement . Did you complete the repair?	Go to Step 12	-
11	IMPORTANT: Perform the set up procedure for the appropriate door module. Refer to <u>Service Programming System (SPS)</u> in Programming. Replace the appropriate door module. Refer to <u>Switch Replacement - Door Lock and Side Window - Driver</u> or <u>Switch Replacement - Door Lock and Side Window - Passenger</u> .Did you complete the repair?	Go to Step 12	-
12	Operate the system in order to verify the repair. Did you correct the condition?	System OK	Go to Step 2

POWER MIRRORS - FOLDING INOPERATIVE

Power Mirrors - Folding Inoperative

Step	Action	Yes	No
Schematic Reference: <u>Outside Mirror Schematics</u> Connector End View Reference: <u>Power Door Systems Connector End Views</u>			
1	Did you perform the Door Systems Diagnostic System Check?	Go to Step 2	Go to <u>Diagnostic System Check - Door Systems</u>
2	<ol style="list-style-type: none"> 1. Turn ON the ignition, with the engine OFF. 2. Place the mirror select switch in the neutral fold position. 3. Activate the mirror direction switch in the left/extend and right/retract positions. Do the outside rearview mirrors extend and retract with the corresponding switch activation?	Go to <u>Testing for Intermittent Conditions and Poor Connections</u> in Wiring Systems	Go to Step 3
3	Are both folding mirrors inoperative?	Go to Step 4	Go to Step 5
4	<ol style="list-style-type: none"> 1. Install a scan tool. 2. Monitor the mirror select switch and the mirror switch data parameters. 3. Activate the mirror select switch left, right and neutral/fold positions. 4. Activate the left/extend and right/retract functions from the mirror switch. Do all of the data parameters change with the corresponding switch activations?	Go to Step 5	Go to Step 6

5	<ol style="list-style-type: none"> 1. Install a scan tool. 2. With the scan tool, observe the Mirror Folding Operation data parameter in the appropriate door module data list. 3. Command the inoperative mirror to retract and extend using the mirror switch. <p>Does the Mirror Folding Operation data parameter change states with the corresponding command?</p>	Go to Step 7	Go to Step 8
6	<p>Inspect for poor connections at the driver door module. Refer to <u>Testing for Intermittent Conditions and Poor Connections</u> and <u>Connector Repairs</u> in Wiring Systems.</p> <p>Did you find and correct the condition?</p>	Go to Step 12	Go to Step 9
7	<p>Inspect for poor connections at the power mirror. Refer to <u>Testing for Intermittent Conditions and Poor Connections</u> and <u>Connector Repairs</u> in Wiring Systems.</p> <p>Did you find and correct the condition?</p>	Go to Step 12	Go to Step 10
8	<p>Inspect for poor connections at the appropriate door module. Refer to <u>Testing for Intermittent Conditions and Poor Connections</u> and <u>Connector Repairs</u> in Wiring Systems.</p> <p>Did you find and correct the condition?</p>	Go to Step 12	Go to Step 11
9	<p>IMPORTANT: Perform the set up procedure for the driver door module. Refer to <u>Service Programming System (SPS)</u> in Programming.</p> <p>Replace the driver door module. Refer to <u>Switch Replacement - Door Lock and Side Window - Driver</u> .Did you complete the repair?</p>	Go to Step 12	-
10	<p>Replace the power mirror. Refer to <u>Mirror Replacement</u> .</p> <p>Did you complete the repair?</p>	Go to Step 12	-
11	<p>IMPORTANT: Perform the set up procedure for the appropriate door module. Refer to <u>Service Programming System (SPS)</u> in Programming.</p> <p>Replace the appropriate door module. Refer to <u>Switch Replacement - Door Lock and Side Window - Driver</u> or <u>Switch Replacement - Door Lock and Side Window - Passenger</u> .Did you complete the repair?</p>	Go to Step 12	-

12	Operate the system in order to verify the repair. Did you correct the condition?	System OK	Go to Step 3
----	---	-----------	---------------------

POWER MIRRORS - MEMORY FUNCTIONS INOPERATIVE

Power Mirrors - Memory Functions Inoperative

Step	Action	Value (s)	Yes	No
Schematic Reference: <u>Outside Mirror Schematics</u>				
Connector End View Reference: <u>Power Door Systems Connector End Views</u>				
1	Did you perform the Door Systems Diagnostic System Check?	-	Go to Step 2	Go to <u>Diagnostic System Check - Door Systems</u>
2	<ol style="list-style-type: none"> Place the mirror select switch in the left mirror position. Activate the mirror position switch in the UP, DOWN, LEFT and RIGHT directions and note the operation. Place the mirror select switch in the right mirror position. Activate the mirror position switch in the UP, DOWN, LEFT and RIGHT directions and note the operation. Do both power mirrors operate properly?	-	Go to Step 3	Go to <u>Power Mirrors Inoperative</u>
3	<ol style="list-style-type: none"> Install a scan tool. Turn ON the ignition, with the engine OFF. Monitor the memory switch data parameters. Are any of the memory switch data parameters active without a switch activation?	-	Go to Step 5	Go to Step 4
4	<ol style="list-style-type: none"> Monitor the memory switch data parameters. Activate the memory 1, memory 2 and Exit switches one at a time. Do all of the memory switch data parameters change state with the corresponding switch activation?	-	Go to Step 7	Go to Step 6

5	<p>Disconnect the memory switch.</p> <p>Does the memory switch data parameter change to idle?</p>	-	Go to Step 13	Go to Step 12
6	<ol style="list-style-type: none"> 1. Disconnect the memory switch. 2. Monitor the memory switch data parameter. 3. Connect a 3-amp fused jumper between the memory switch battery positive voltage pin and each of the memory switch signal pins, one at a time, at the driver door module. <p>Does the memory switch data parameter change state appropriately at each test point?</p>	-	Go to Step 13	Go to Step 12
7	<p>With a scan tool, monitor the Mirror Horizontal and Vertical Position data parameters of the inoperative mirror while commanding the mirror to move with the mirror switch.</p> <p>Do the Mirror Horizontal and Vertical Position data parameters change values with the corresponding mirror movement?</p>	-	Go to Step 10	Go to Step 8
8	<ol style="list-style-type: none"> 1. Disconnect the inoperative mirror. 2. Measure the voltage between the mirror 5-volt reference circuit pin at the door module and a good ground. <p>Does the voltage measure within the specified range?</p>	4.75-5.0 V	Go to Step 9	Go to Step 12
9	<ol style="list-style-type: none"> 1. With a scan tool, monitor the Mirror Horizontal and Vertical Position data parameters. 2. Connect a 3-amp fused jumper between the mirror 5-volt reference circuit pin and each of the horizontal and vertical position signal circuit pins at the door module one at a time. <p>Do the Mirror Horizontal and Vertical Position data parameters display within the specified range?</p>	4.75-5.0 V	Go to Step 14	Go to Step 10
	<ol style="list-style-type: none"> 1. Connect the inoperative mirror. 2. Backprobe the mirror 5-volt reference circuit with a DMM connected to a 			

10	<p>good ground.</p> <p>3. Monitor the voltage displayed on the DMM while commanding the mirror to the full up, down, left and right positions with the mirror position switch.</p> <p>Does the measured voltage display greater than the specified value?</p>	5.0 V	Go to Step 14	Go to Step 11
11	<ol style="list-style-type: none"> 1. Command the mirror to move with the mirror switch to the full up and full left position. 2. Press and hold the memory 1 switch until two audible tones are heard. 3. With a scan tool, monitor and record the Mirror Horizontal and Vertical Position data parameter voltage values. 4. Command the mirror to move with the mirror switch to the full down and full right position. 5. Press and release the memory 1 switch. <p>Does the mirror recall to within 0.02 volts of the stored Mirror Horizontal and Vertical Position data parameter voltage values recorded earlier?</p>	Within 0.2 V	Go to Testing for Intermittent Conditions and Poor Connections in Wiring Systems	Go to Step 12
12	<p>Inspect for poor connections at the appropriate door module. Refer to Testing for Intermittent Conditions and Poor Connections and Connector Repairs in Wiring Systems.</p> <p>Did you find and correct the condition?</p>	-	Go to Step 18	Go to Step 15
13	<p>Inspect for poor connections at the memory switch. Refer to Testing for Intermittent Conditions and Poor Connections and Connector Repairs in Wiring Systems.</p> <p>Did you find and correct the condition?</p>	-	Go to Step 18	Go to Step 16
14	<p>Inspect for poor connections at the appropriate mirror. Refer to Testing for Intermittent Conditions and Poor Connections and Connector Repairs in Wiring Systems.</p> <p>Did you find and correct the condition?</p>	-	Go to Step 18	Go to Step 17

	IMPORTANT: Perform the set up procedure for the appropriate door module. Refer to <u>Service Programming System (SPS)</u> in Programming.			
15	Replace the appropriate door module. Refer to <u>Switch Replacement - Door Lock and Side Window - Driver</u> or <u>Switch Replacement - Door Lock and Side Window - Passenger</u> .Did you complete the repair?	-	Go to Step 18	-
16	Replace the memory switch. Refer to <u>Heated Seat Switch Replacement - Front</u> in Seats. Did you complete the repair?	-	Go to Step 18	-
17	Replace the appropriate mirror. Refer to <u>Mirror Replacement</u> in Seats. Did you complete the repair?	-	Go to Step 18	-
18	Operate the system in order to verify the repair. Did you correct the condition?	-	System OK	Go to Step 2

MIRRORS - OUTSIDE AUTOMATIC DAY-NIGHT FEATURE INOPERATIVE

Mirrors - Outside Automatic Day-Night Feature Inoperative

Step	Action	Value (s)	Yes	No
Schematic Reference: Outside Mirror Schematics				
Connector End View Reference: Stationary Windows Connector End Views				
1	Did you review the operation of the automatic day-night feature of the driver outside rearview mirror and perform the necessary inspections?	-	Go to Step 2	Go to Symptoms - Doors
2	<ol style="list-style-type: none"> Turn ON the ignition, with the engine OFF. Turn OFF the automatic day-night feature of the inside rearview mirror. <p>Observe the driver outside rearview mirror.</p> <p>Does the driver outside rearview mirror remain in a darken state?</p>	-	Go to Step 11	Go to Step 3
	<ol style="list-style-type: none"> Turn ON the automatic day-night 			

3	<p>feature of the inside rearview mirror.</p> <ol style="list-style-type: none"> Cover the sensor on the mirror back, facing the front window. Shine a bright light into the sensor on the mirror face, facing the rear window. <p>Does the inside rearview mirror darken?</p>	-	Go to Step 4	Go to Mirrors - Automatic Day-Night Inoperative in Stationary Windows
4	<p>While shining a bright light into the sensor on the face of the inside rearview mirror, observe the driver outside rearview mirror. Does the driver outside rearview mirror darken?</p>	0.75-1.5 V	Go to Testing for Intermittent Conditions and Poor Connections in Wiring Systems	Go to Step 5
5	<ol style="list-style-type: none"> Turn OFF the ignition. Disconnect the harness connector of the driver outside rearview mirror. Turn ON the ignition, with the engine OFF. Turn ON the automatic day-night feature of the inside rearview mirror. Cover the sensor on the mirror back, facing the front window. Shine a bright light into the sensor on the mirror face, facing the rear window. Measure the voltage between the signal circuit and the low reference circuit of the driver outside rearview mirror element. <p>Is the voltage within the specified range?</p>	0.75-1.5 V	Go to Step 9	Go to Step 6
6	<p>Measure the voltage between the signal circuit of the driver outside rearview mirror element and a good ground. Is the voltage within the specified range?</p>	0.75-1.5 V	Go to Step 8	Go to Step 7
7	<p>Test the signal circuit of the driver outside rearview mirror element for an open or high resistance. Refer to Circuit Testing and Wiring Repairs in Wiring Systems. Did you find or correct the condition?</p>	-	Go to Step 14	Go to Step 10
8	<p>Test the low reference circuit of the driver outside rearview mirror element for an open or high resistance. Refer to Circuit Testing and Wiring Repairs in Wiring Systems.</p>	-		

	Did you find or correct the condition?		Go to Step 14	Go to Step 10
9	Inspect for poor connections at the harness connector of the driver outside rearview mirror. Refer to Testing for Intermittent Conditions and Poor Connections and Connector Repairs in Wiring Systems. Did you find or correct the condition?	-	Go to Step 14	Go to Step 12
10	Inspect for poor connections at the harness connector of the inside rearview mirror. Refer to Testing for Intermittent Conditions and Poor Connections and Connector Repairs in Wiring Systems. Did you find or correct the condition?	-	Go to Step 14	Go to Step 13
11	IMPORTANT: A short to voltage in the signal circuit of the driver outside rearview mirror element will cause permanent damage to both the driver outside rearview mirror element and the inside rearview mirror. Repair the short to voltage in the signal circuit of the driver outside rearview mirror element. Refer to Wiring Repairs in Wiring Systems. Did you complete the repair?	-	Go to Step 14	-
12	Replace the driver outside rearview mirror. Refer to Mirror Replacement . Did you complete the replacement?	-	Go to Step 14	-
13	IMPORTANT: Perform the setup procedure for the inside rearview mirror with compass. Refer to Compass Calibration and Variance Procedure in Stationary Windows. Replace the inside rearview mirror. Refer to Rearview Mirror Replacement in Stationary Windows. Did you complete the replacement?	-	Go to Step 14	-
14	Operate the system in order to verify the repair. Did you correct the condition?	-	System OK	Go to Step 2

HEATED MIRRORS INOPERATIVE

Heated Mirrors Inoperative

Step	Action	Yes	No
------	--------	-----	----

Schematic Reference: Outside Mirror Schematics

1	Did you perform the Door Systems Diagnostic System Check?	Go to Step 2	Go to <u>Diagnostic System Check - Door Systems</u>
2	Verify the heated mirrors inoperative fault is present. Do the heated mirrors operate normally?	Go to <u>Testing for Intermittent Conditions and Poor Connections</u> in Wiring Systems	Go to Step 3
3	Does the rear window defogger operate properly?	Go to Step 4	Go to <u>Defogger Inoperative - Rear Window</u> in Stationary Windows
4	<ol style="list-style-type: none"> 1. Disconnect the appropriate mirror. 2. Start the engine. 3. Connect a test lamp between the mirror heater control and the mirror heater ground circuit pins of the appropriate door module. 4. Activate the rear window defogger switch. <p>Does the test lamp illuminate?</p>	Go to Step 5	Go to Step 6
5	Inspect for poor connections at the harness connector of the outside rearview mirror. Refer to <u>Testing for Intermittent Conditions and Poor Connections</u> and <u>Connector Repairs</u> in Wiring Systems. Did you find and correct the condition?	Go to Step 9	Go to Step 7
6	Inspect for poor connections at the harness connector of the appropriate door module. Refer to <u>Testing for Intermittent Conditions and Poor Connections</u> and <u>Connector Repairs</u> in Wiring Systems. Did you find and correct the condition?	Go to Step 9	Go to Step 8
7	Replace the appropriate outside rearview mirror face. Did you complete the replacement?	Go to Step 9	-
8	<p>IMPORTANT: Perform the set up procedure for the appropriate door module. Refer to <u>Service Programming System (SPS)</u> in Programming.</p> <p>Replace the appropriate door module. Refer to <u>Switch Replacement - Door Lock and Side Window - Driver</u> or <u>Switch Replacement - Door Lock and Side Window - Passenger</u> .Did you complete the replacement?</p>	Go to Step 9	-

9

Operate the system in order to verify the repair.
Did you correct the condition?

System OK

Go to **Step 2**

REPAIR INSTRUCTIONS

POWER WINDOW SWITCH REPLACEMENT - REAR DOOR

Removal Procedure

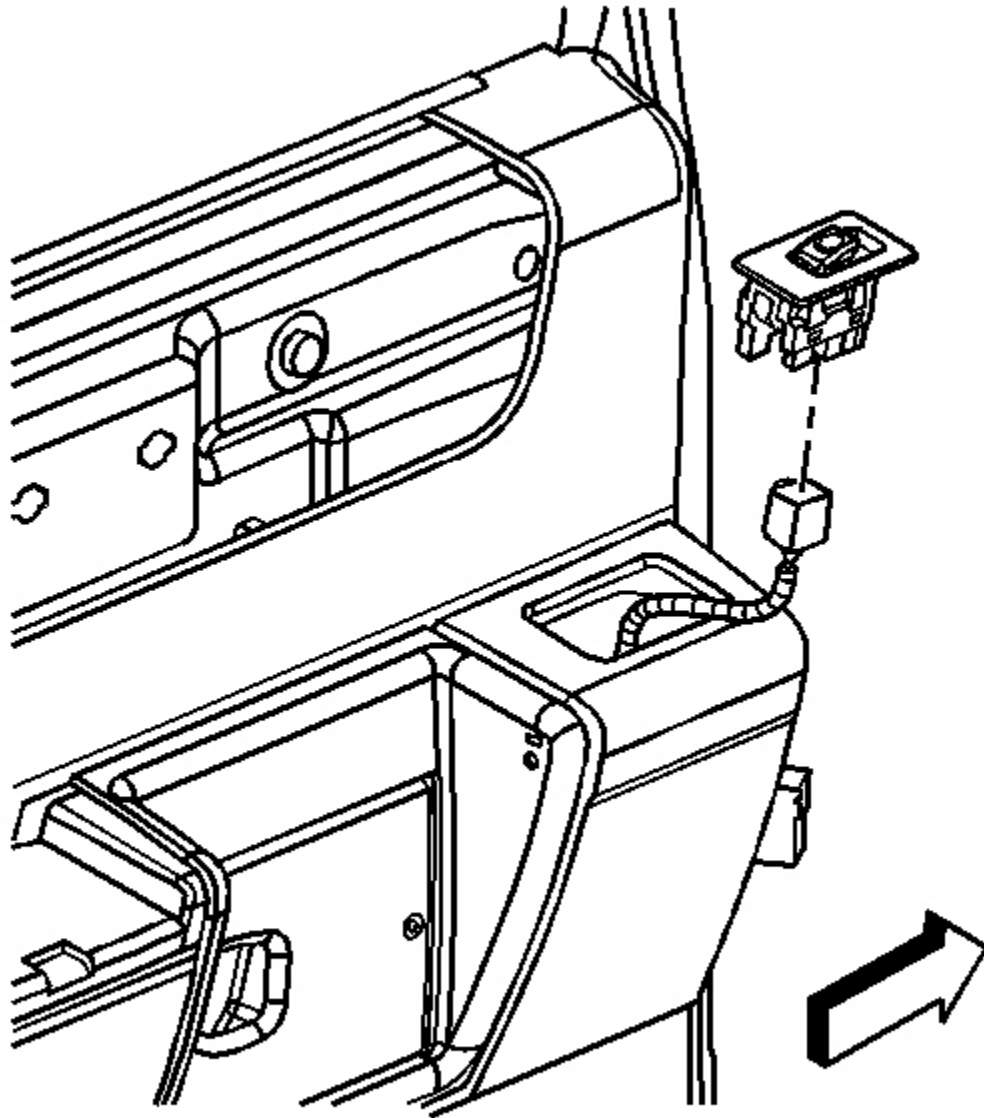

Fig. 14: Rear Door Power Window Switch
Courtesy of GENERAL MOTORS CORP.

1. Use a suitable flat bladed tool to remove the power window switch from the door panel.
2. Remove the power window switch from the connector.

Installation Procedure

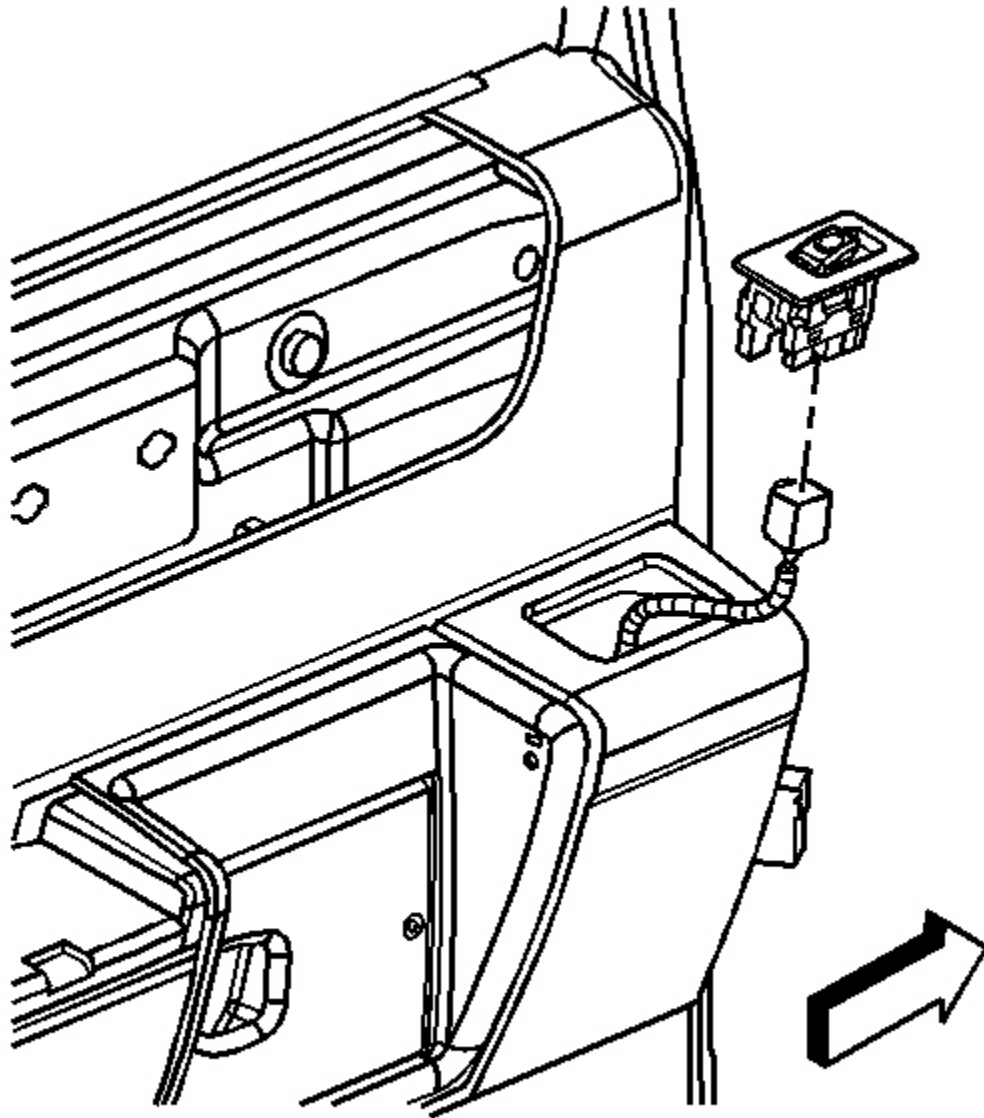

Fig. 15: Rear Door Power Window Switch
Courtesy of GENERAL MOTORS CORP.

1. Install the power window switch to the connector.
2. Align the power window switch with the opening in the door panel and press to seat the switch.

SWITCH REPLACEMENT - DOOR LOCK AND SIDE WINDOW - DRIVER

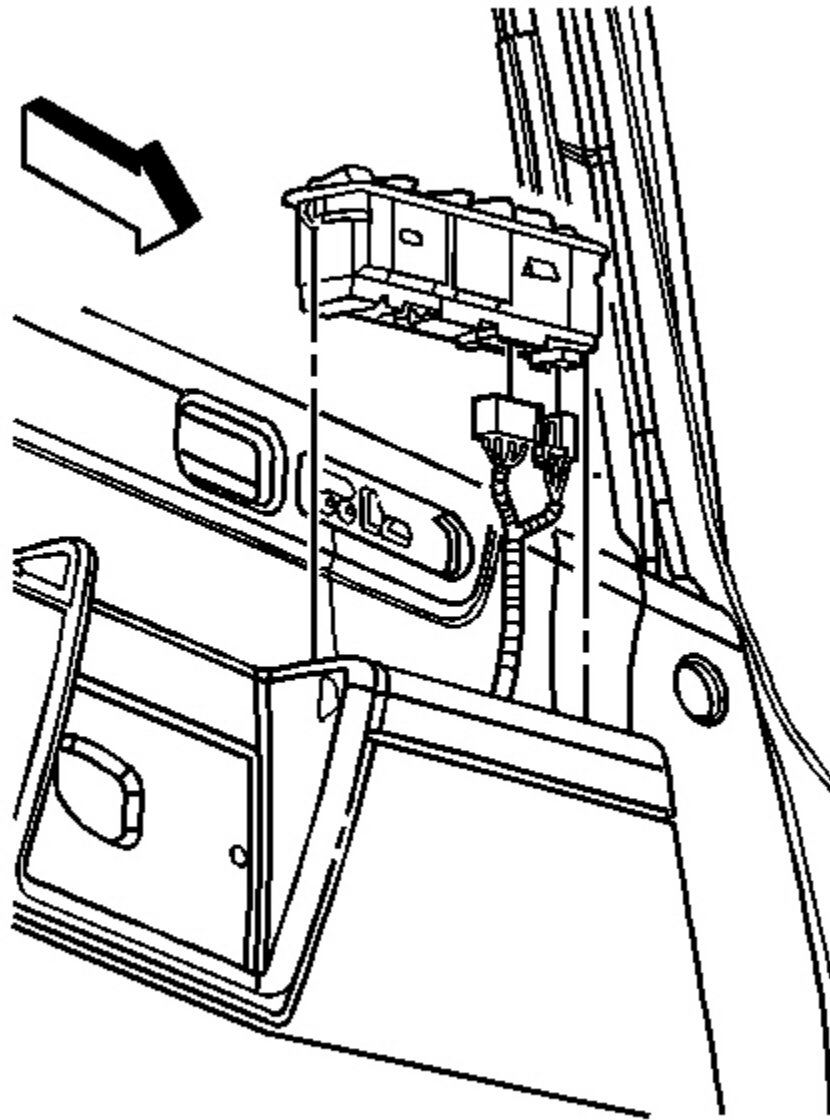

Fig. 16: Driver Door Lock & Side Window Switch
Courtesy of GENERAL MOTORS CORP.

1. Use a suitable flat bladed tool to remove the driver door lock and side window switch from the door trim panel.

2. Remove the driver door lock and side window switch from the connector.

Installation Procedure

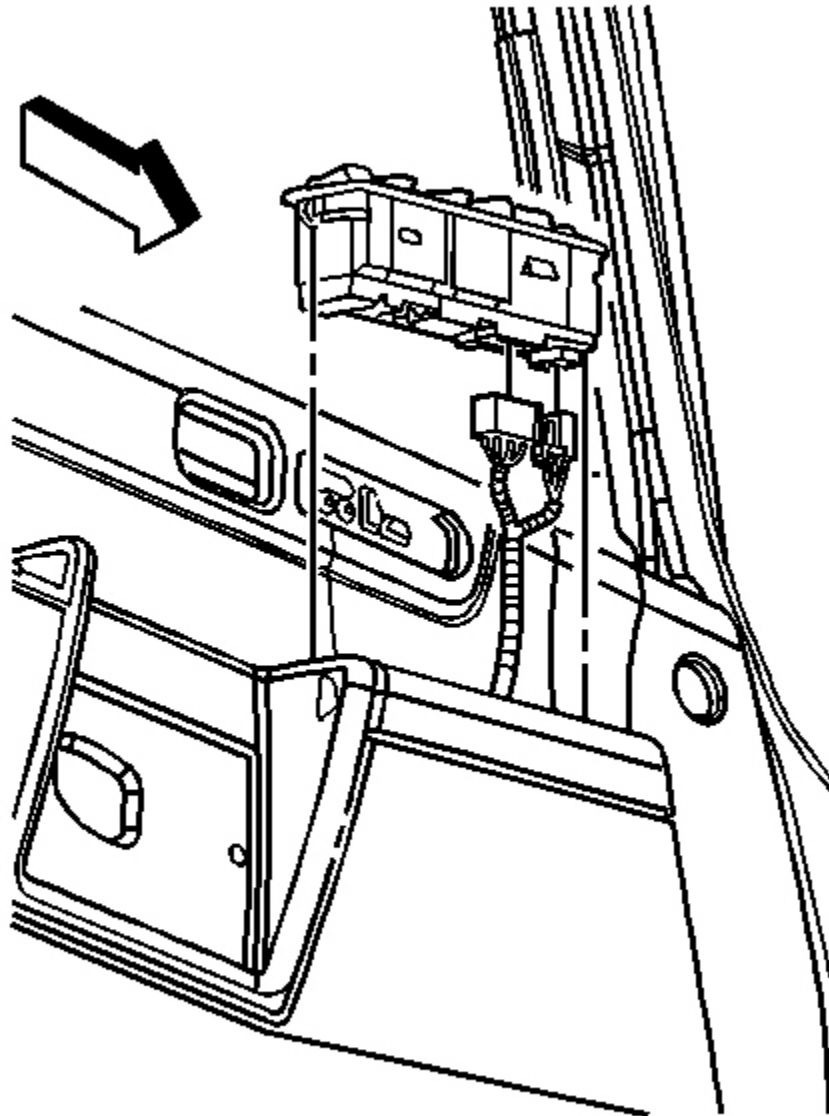

Fig. 17: Driver Door Lock & Side Window Switch
Courtesy of GENERAL MOTORS CORP.

1. Install the driver door lock and side window switch to the connector.
2. Align the driver door lock and side window switch with the opening in the door panel and press to seat the switch.

SWITCH REPLACEMENT - DOOR LOCK AND SIDE WINDOW - PASSENGER

Removal Procedure

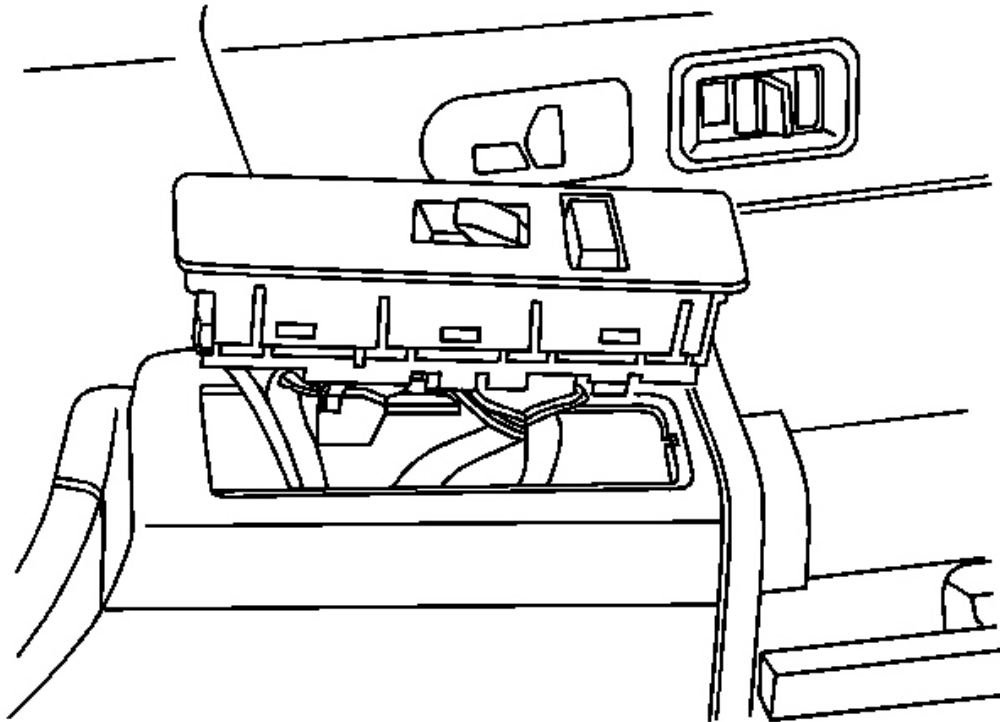

Fig. 18: Passenger Door Lock & Side Window Switch
Courtesy of GENERAL MOTORS CORP.

1. Use a suitable flat-bladed tool to remove the door lock and side window switch from the door panel.
2. Disconnect the electrical connector from the switch.

Installation Procedure

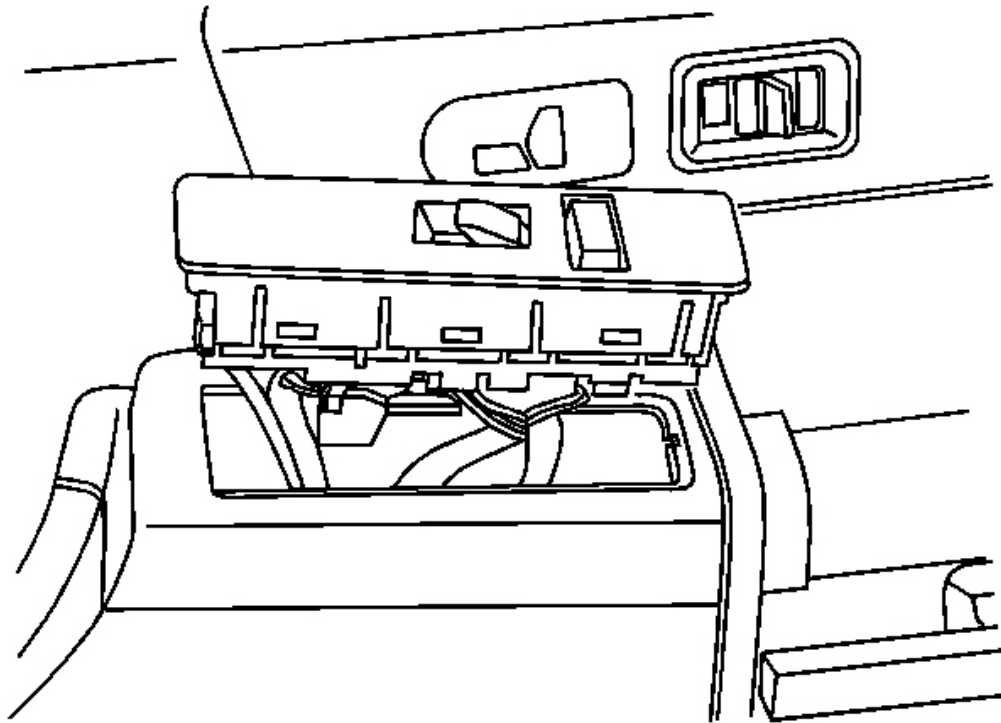

Fig. 19: Passenger Door Lock & Side Window Switch
Courtesy of GENERAL MOTORS CORP.

1. Connect the electrical connector to the door lock and side window switch.
2. Align the switch with the opening in the door panel. Press to seat the switch.
3. Program the keyless entry transmitters if the module has been replaced. Refer to **Transmitter Programming** in Keyless Entry.

HANDLE BEZEL REPLACEMENT - INSIDE

Removal Procedure

1. Remove the door trim panel. Refer to **Trim Panel Replacement - Side Front Door** or **Trim Panel Replacement - Side Rear Door** .
2. Place the door trim panel, back-side up, on a clean prepared non-abrasive surface.

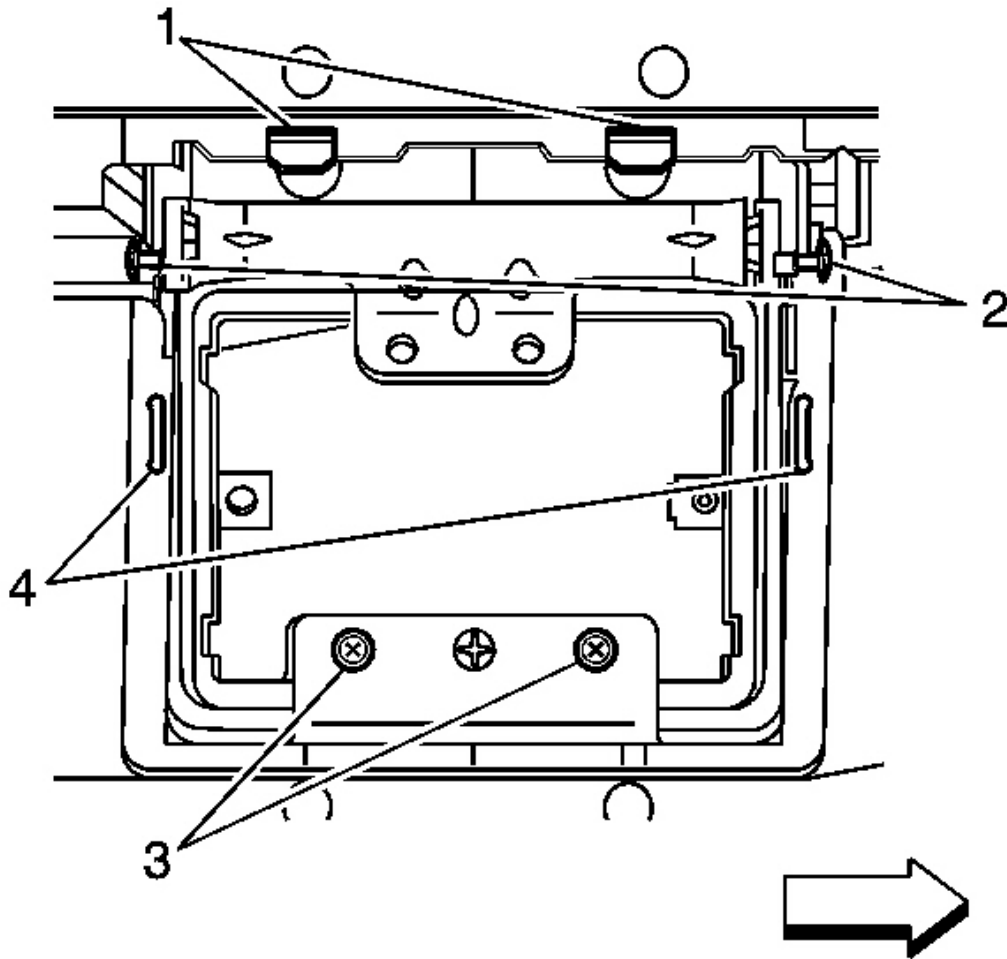

Fig. 20: Inside Pull Handle Bezel Assembly
Courtesy of GENERAL MOTORS CORP.

3. Locate the 2 lower heat-stakes holding the pull handle bezel assembly to the door panel (3).

IMPORTANT: If the heat-stake is beaded, grin off the bead. Do not remove any door trim material.

4. Using a 8 mm (5/16 in) drill bit, drill through the round heat-staked studs (3).

Drill into the heat-staked stud just enough to cause the stud material to separate from the door panel.

5. Using a Dremel tool or equivalent, remove any heat-stake material that may be left in the door panel holes or on the door panel.
6. Grind off the heat-stake material (4).
7. Remove the screws (2).
8. Using pliers, straighten the pull handle bezel tabs (1). Grind any remaining material if necessary.
9. Remove the pull handle bezel assembly from the door panel.

Installation Procedure

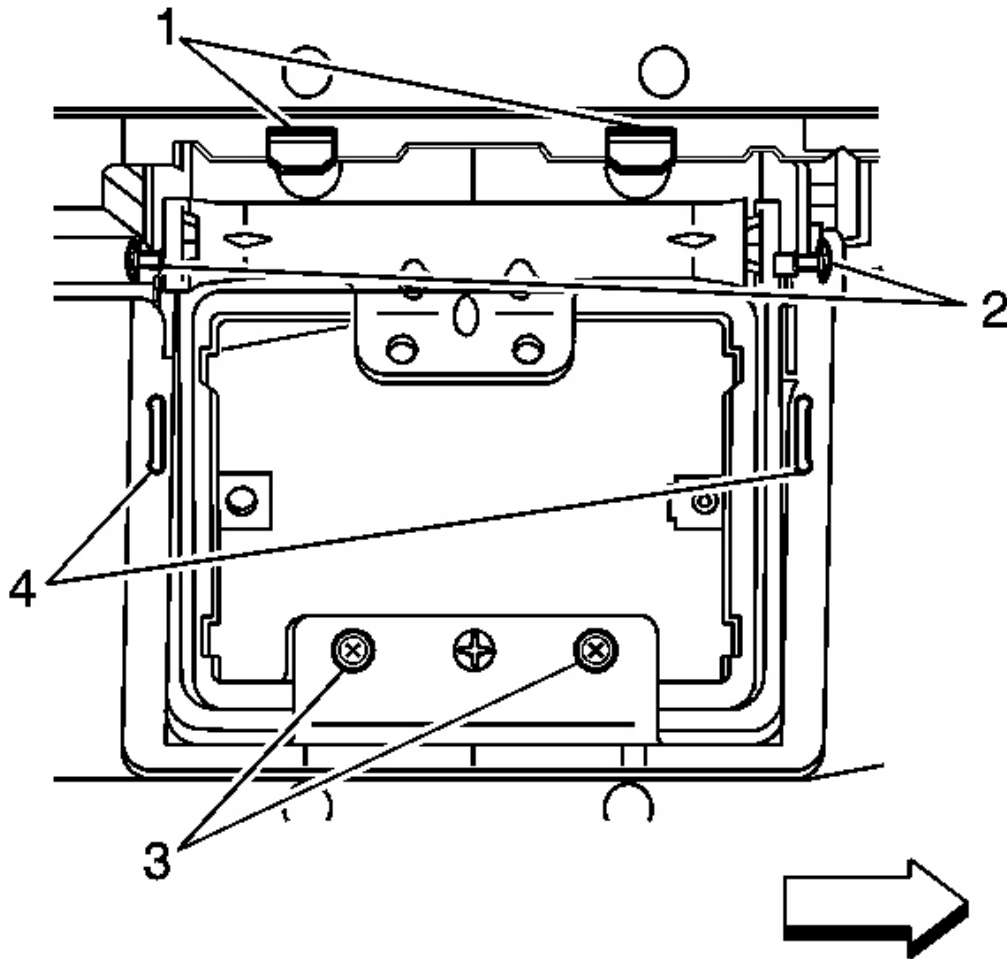

Fig. 21: Inside Pull Handle Bezel Assembly
Courtesy of GENERAL MOTORS CORP.

1. Position the replacement pull handle bezel assembly to the door trim panel.
2. Place the door trim panel, back-side up, on a clean prepared non-abrasive surface.

NOTE: Refer to Fastener Notice in Cautions and Notices.

3. Install the 2 screws (2).

Tighten: Tighten the screws to 2.8 N.m (25 lb in).

4. Use clamps to temporarily secure handle bezel to door trim panel.
5. Using a Weller model 8200 soldering gun, or equivalent, equipped with a flat tip, heat and bend the tabs (1) securing the handle bezel to the door panel.
6. Heat the tabs (4) securing the handle bezel to the door panel.

IMPORTANT: A desirable round heat-stake weld should have an approximate diameter of 13 mm (1/2 in) and height 2 mm (3/32 in).

7. Use a soldering gun equipped with a flat tip. Using a circular motion, apply firm steady pressure to spread the heat-stake (3) material into the door trim panel to achieve a proper weld.
8. Allow for heat-stakes to cool and remove clamps.
9. Verify that the pull handle bezel is securely heat-staked to the door trim panel.
10. Install the door trim panel. Refer to **Trim Panel Replacement - Side Front Door** or **Trim Panel Replacement - Side Rear Door** .

HANDLE BEZEL REPLACEMENT - INSIDE - FRONT

Removal Procedure

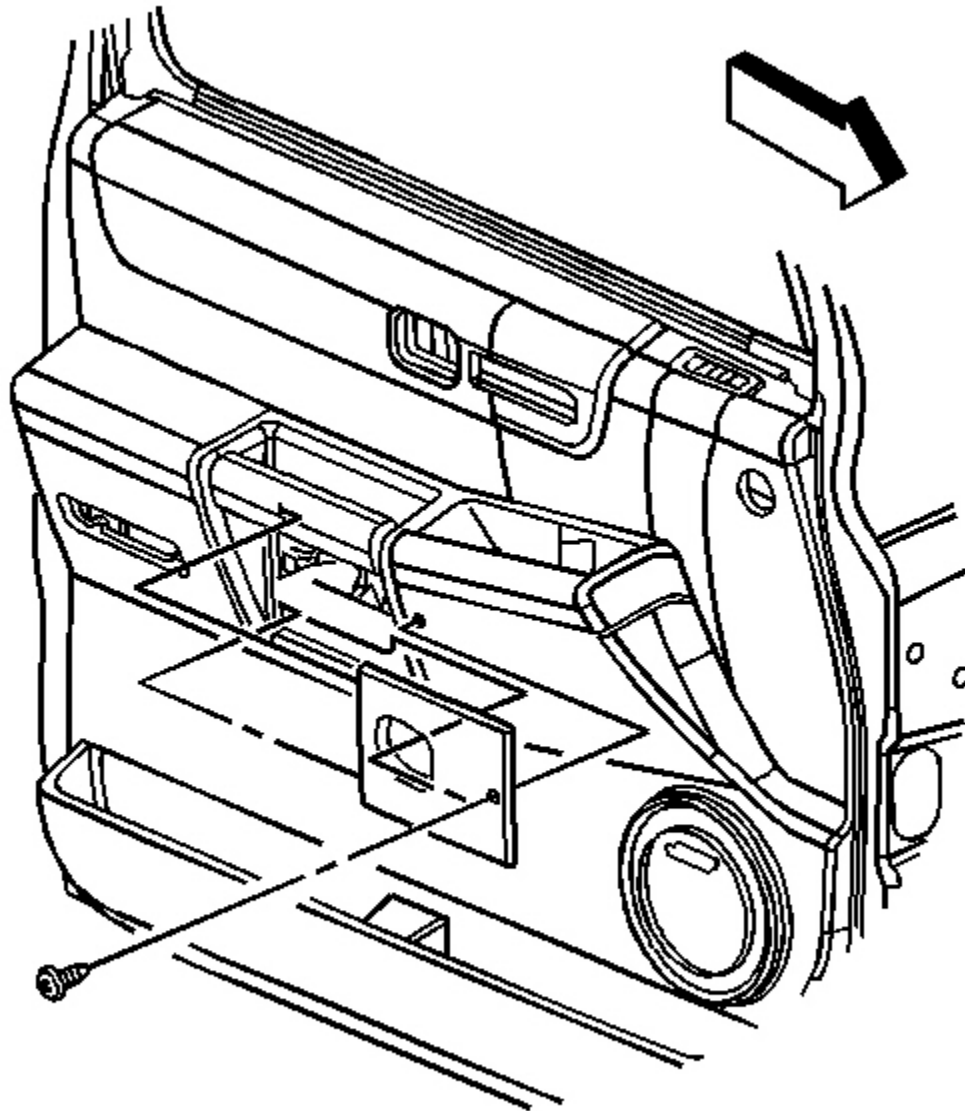

Fig. 22: Inside Front Handle Bezel
Courtesy of GENERAL MOTORS CORP.

1. Remove the screw that retains the front inside handle bezel to the door panel.
2. Remove the bezel from around the door handle,
3. Remove the bezel from the vehicle.

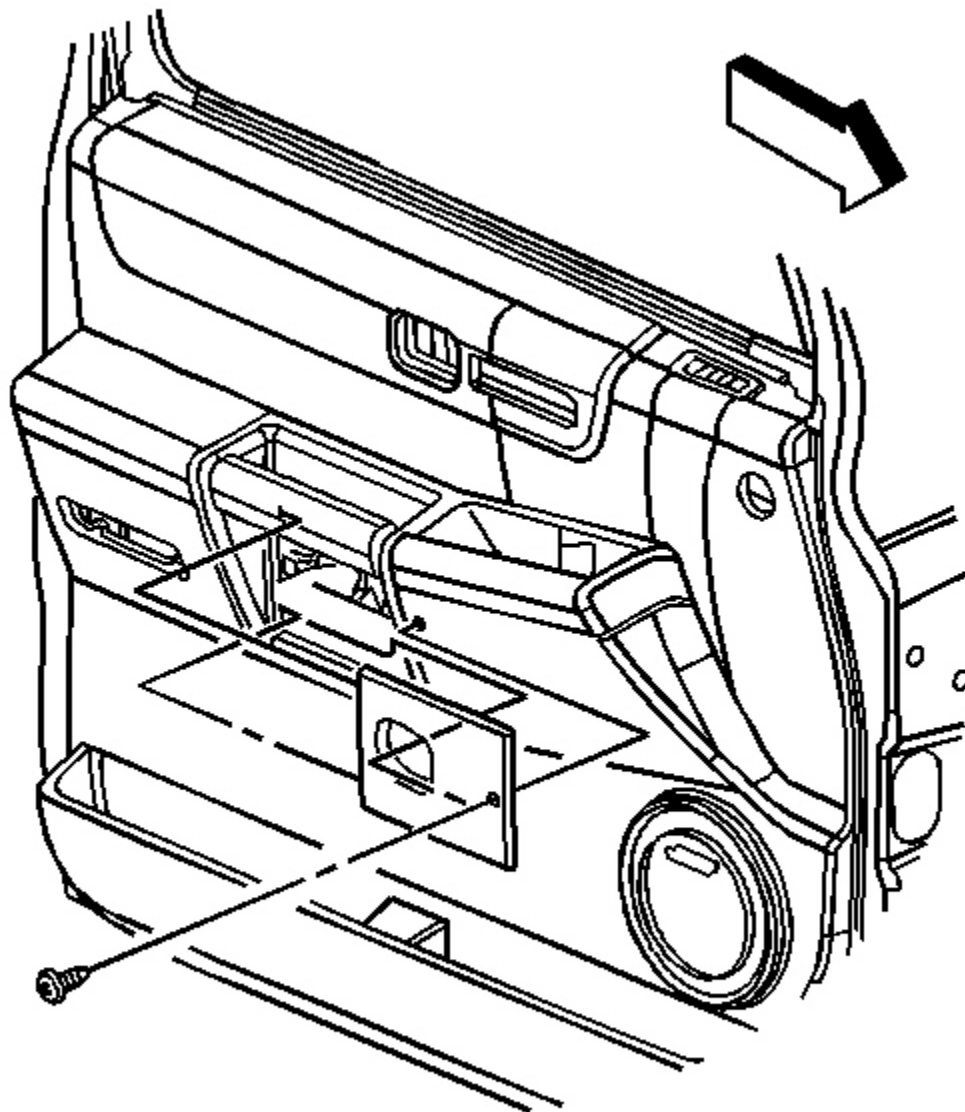

Fig. 23: Inside Front Handle Bezel
Courtesy of GENERAL MOTORS CORP.

1. Install the bezel to the vehicle.
2. Install the bezel around the door handle.

3. Install the screw that retains the handle bezel to the door panel.

HANDLE BEZEL REPLACEMENT - INSIDE - REAR

Removal Procedure

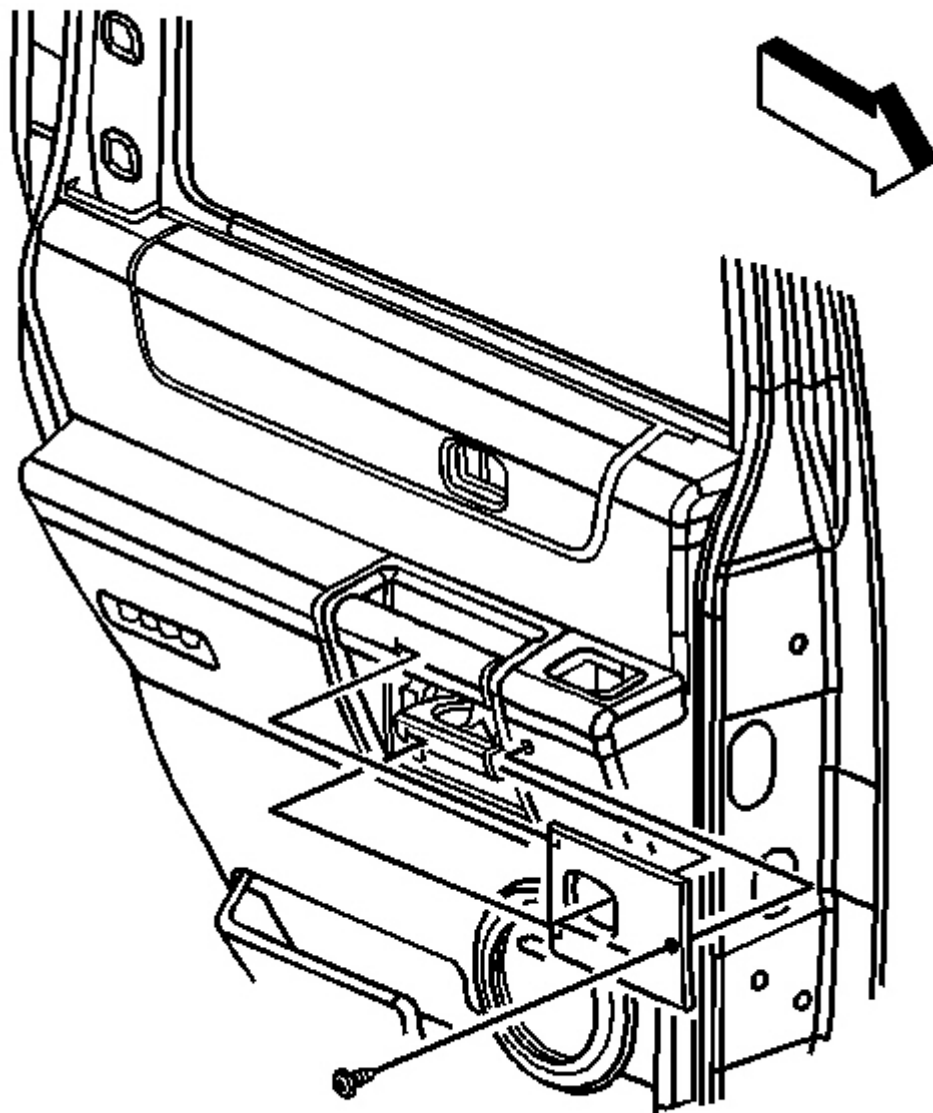

Fig. 24: Inside Rear Handle Bezel
Courtesy of GENERAL MOTORS CORP.

1. Remove the screw that retains the rear inside handle bezel to the door panel.
2. Remove the bezel from around the door handle.
3. Remove the bezel from the vehicle.

Installation Procedure

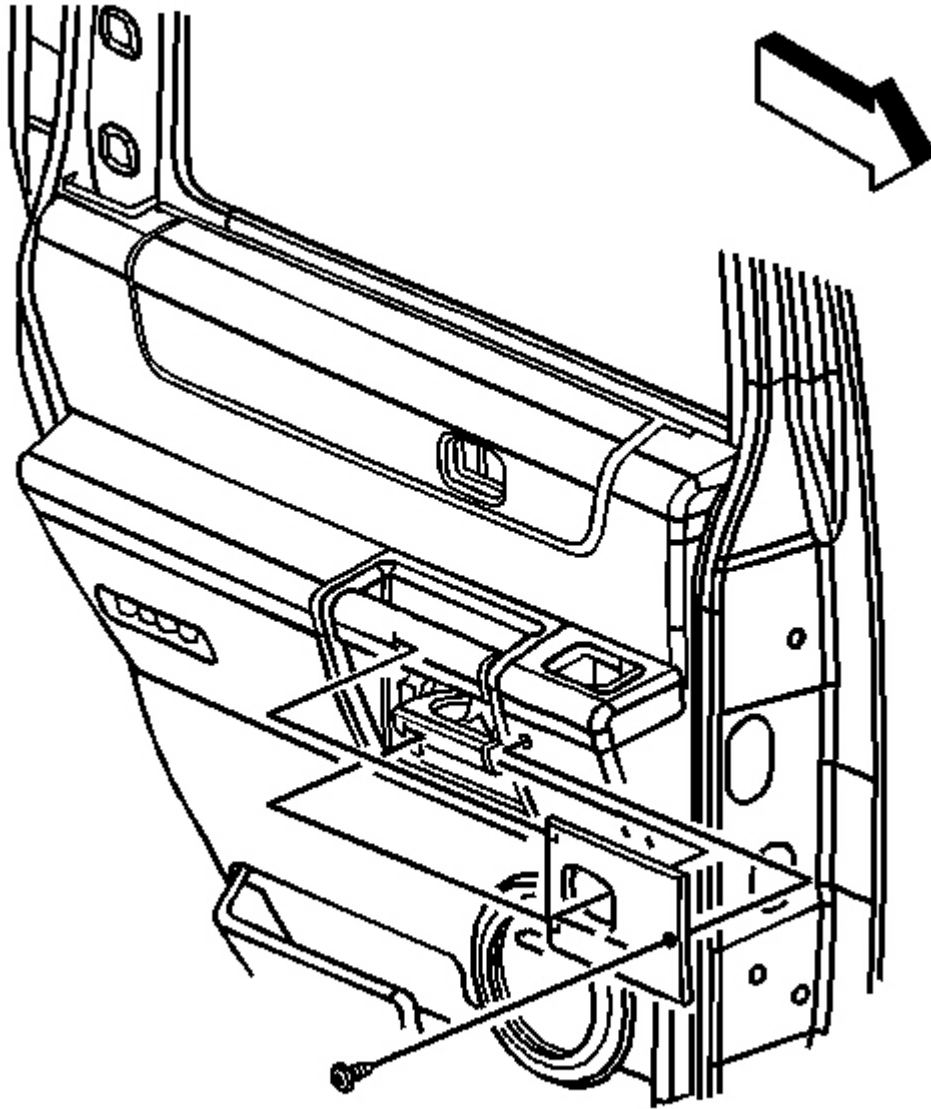

Fig. 25: Inside Rear Handle Bezel

Courtesy of GENERAL MOTORS CORP.

1. Install the bezel to the vehicle.
2. Install the bezel around the door handle.
3. Install the screw that retains the handle bezel to the door panel.

TRIM PANEL REPLACEMENT - UPPER EXTENSION

Removal Procedure

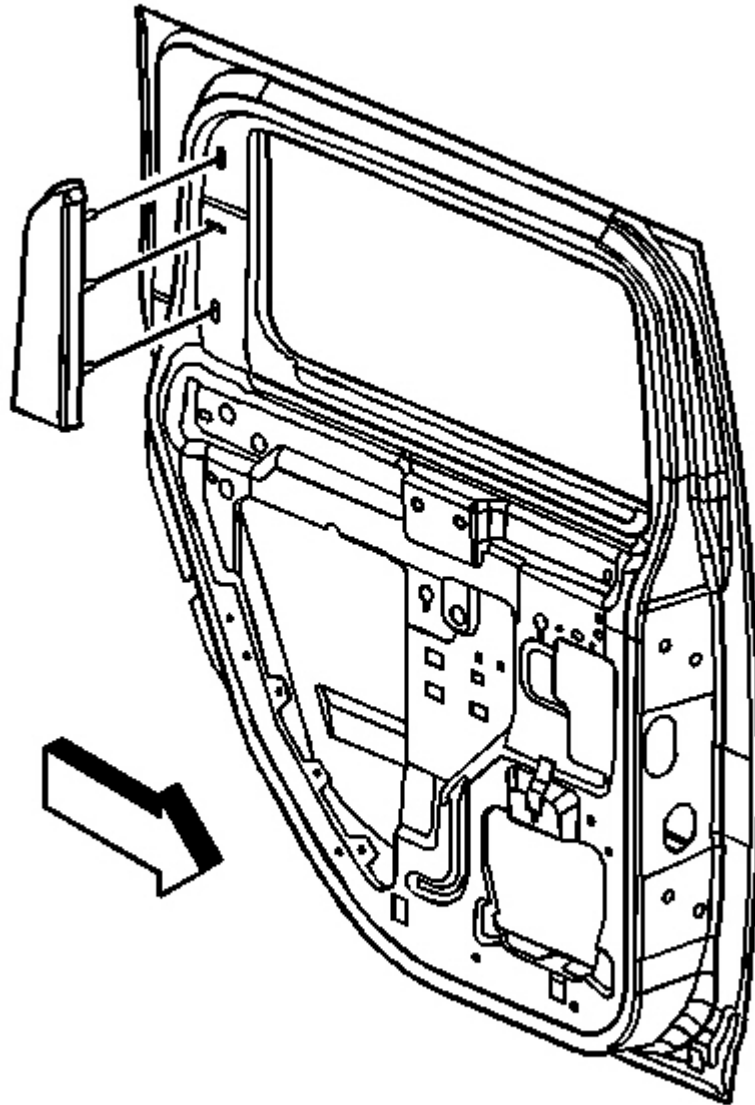

Fig. 26: Upper Extension Trim Panel
Courtesy of GENERAL MOTORS CORP.

1. Firmly grasp and gently pull to disengage the retaining clips.
2. Inspect for broke or missing retaining clips and replace as necessary.

Installation Procedure

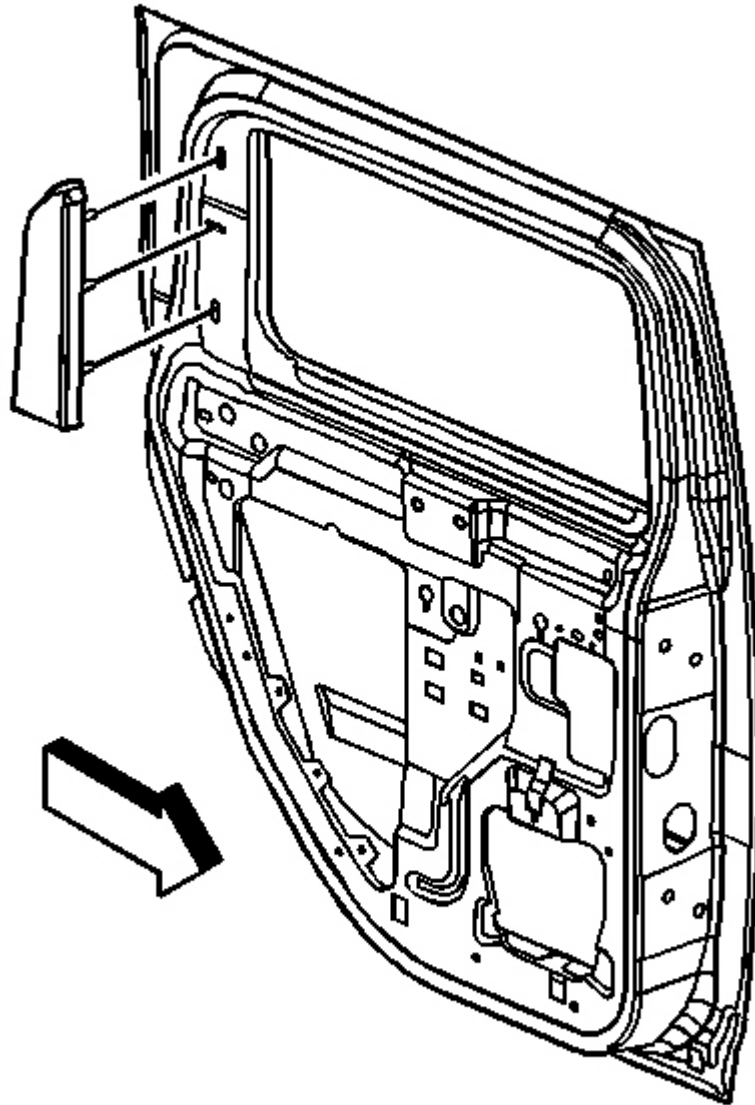

Fig. 27: Upper Extension Trim Panel
Courtesy of GENERAL MOTORS CORP.

1. Align the retaining clips with the openings in the body.
2. Press to fully seat the retaining clips.

TRIM PANEL REPLACEMENT - SIDE FRONT DOOR

Tools Required

J 38778 Door Trim Pad Clip Remover. See Special Tools and Equipment .

Removal Procedure

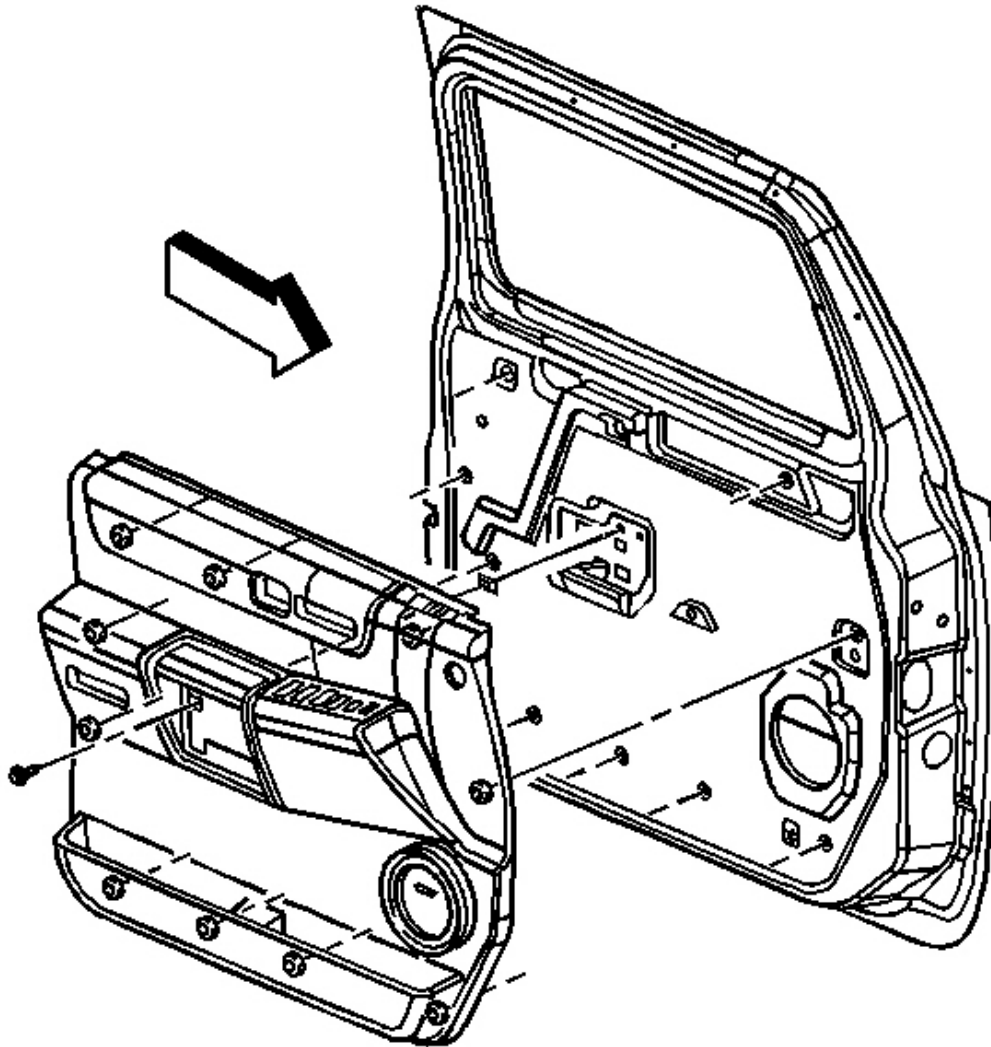

Fig. 28: Side Front Door Trim Panel
Courtesy of GENERAL MOTORS CORP.

1. Remove the door handle bezel. Refer to **Handle Bezel Replacement - Inside - Front**

2. Remove the door panel retaining screw located in the handle bezel opening.
3. Remove the door window switch. Refer to **Switch Replacement - Door Lock and Side Window - Driver** or **Switch Replacement - Door Lock and Side Window - Passenger** .
4. Use special tool **J 38778** to release the door trim panel retaining clips. See **Special Tools and Equipment** .
5. Disconnect the electrical wiring harness connectors.
6. Remove the door trim panel from the vehicle.

Installation Procedure

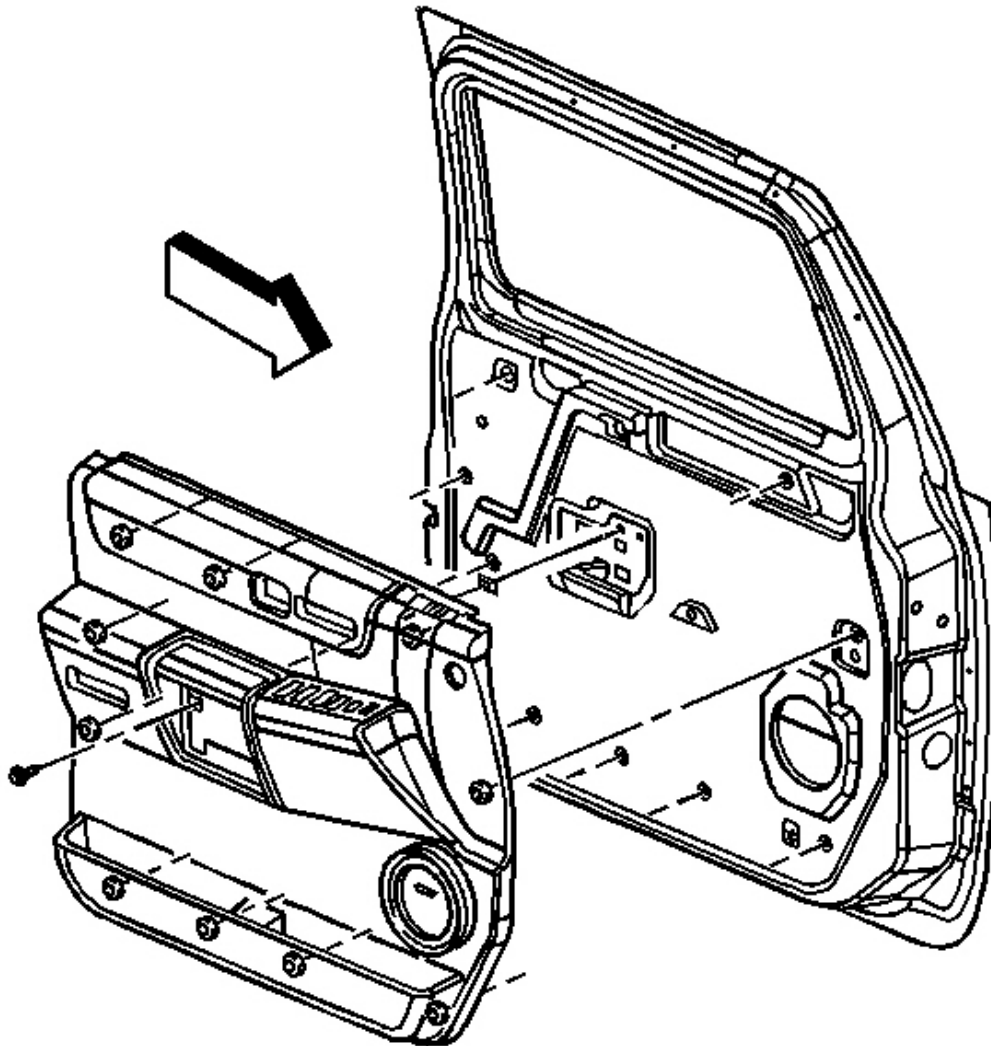

Fig. 29: Side Front Door Trim Panel
Courtesy of GENERAL MOTORS CORP.

1. Connect the electrical wiring harness connectors.
2. Install the door trim panel to the vehicle.
 1. Align the door trim panel retaining clips with the openings in the door.
 2. Push inward on the door trim panel to engage the fasteners.
3. Install the door window switch. Refer to **Switch Replacement - Door Lock and Side Window - Driver** or **Switch Replacement - Door Lock and Side Window - Passenger** .

4. Install the door panel retaining screw within the handle bezel opening.
5. Install the door handle bezel. Refer to **Handle Bezel Replacement - Inside - Front** .

TRIM PANEL REPLACEMENT - SIDE REAR DOOR

Tools Required

J 38778 Door Trim Pad Clip Remover. See **Special Tools and Equipment** .

Removal Procedure

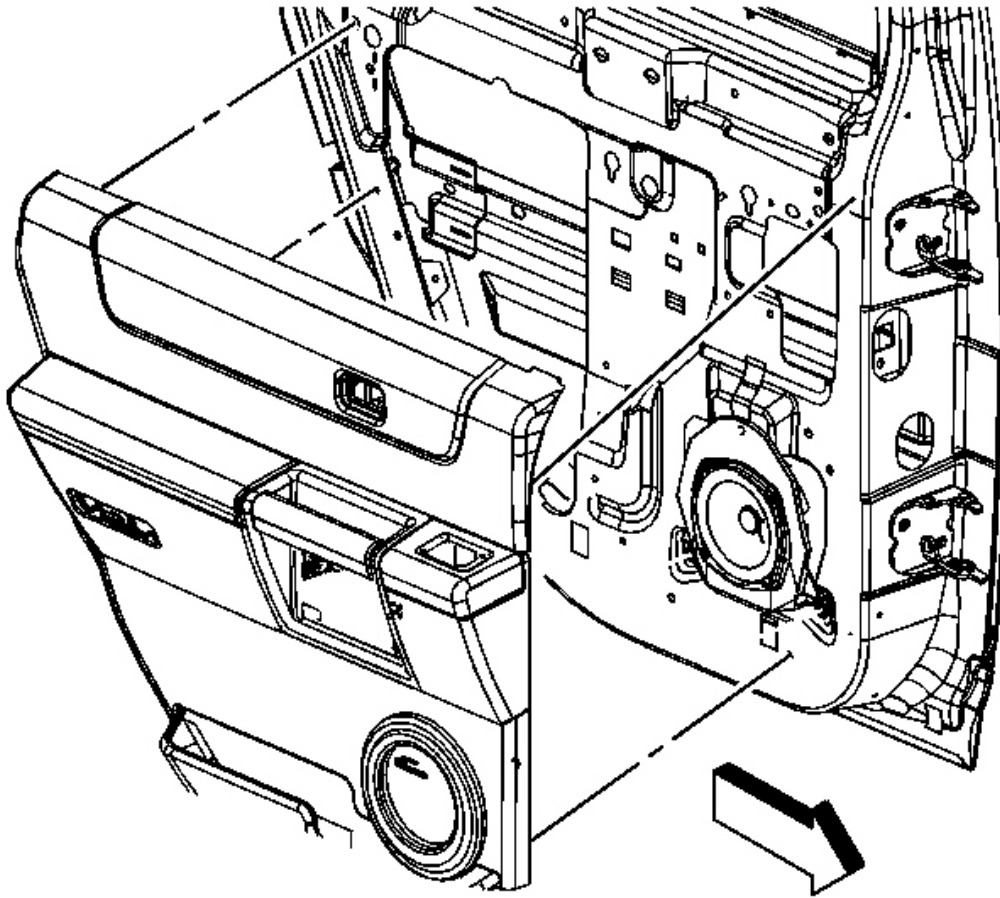

Fig. 30: Side Rear Door Trim Panel
Courtesy of GENERAL MOTORS CORP.

1. Remove the upper door trim panel. Refer to **Trim Panel Replacement - Upper Extension** .

2. Remove the rear door handle bezel. Refer to **Handle Bezel Replacement - Inside - Rear**
3. Remove the door panel retaining screw located in the handle bezel opening.
4. Use **J 38778** to release the retaining clips from the door trim panel. See **Special Tools and Equipment** .
5. Disconnect the electrical wiring harness connectors.
6. Remove the door trim panel from the vehicle.
7. Inspect for missing or broken retaining fasteners. Replace the fasteners as necessary.

Installation Procedure

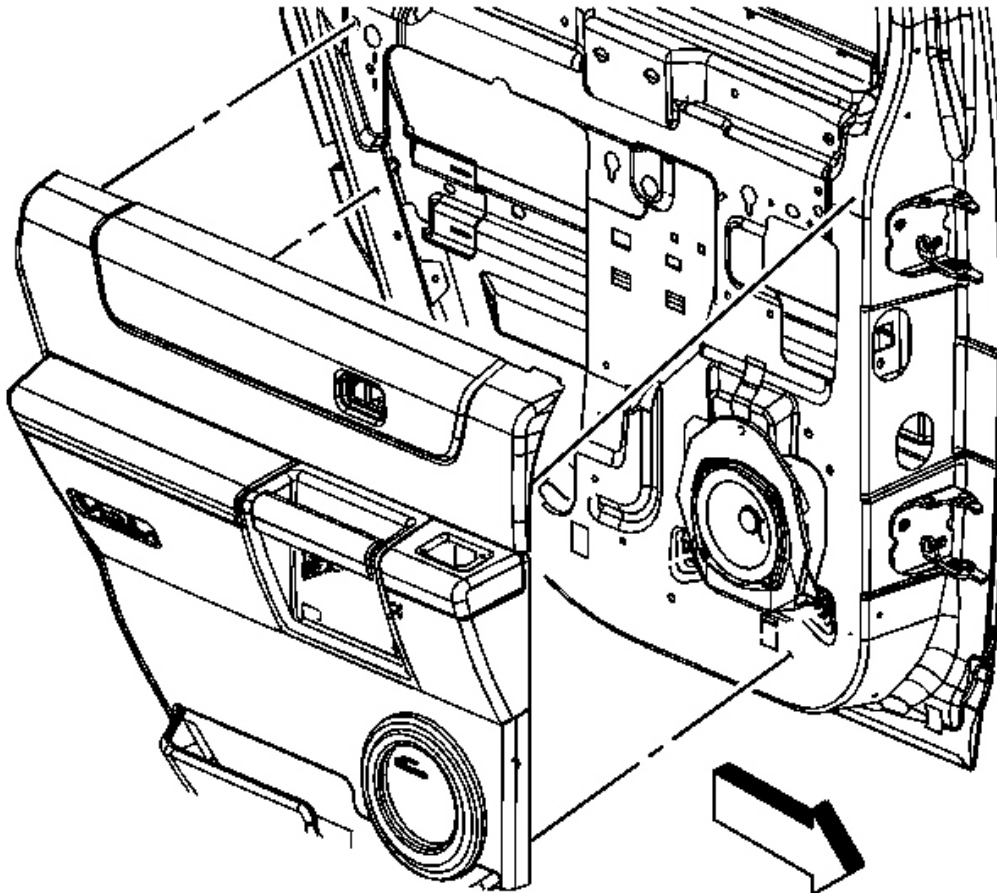

Fig. 31: Side Rear Door Trim Panel
Courtesy of GENERAL MOTORS CORP.

1. Connect the electrical wiring harness connectors.

2. Install the door trim panel to the vehicle.
 1. Align the door trim panel retaining clips with the openings in the door.
 2. Push inward on the door trim panel to engage the fasteners.
3. Install the door panel retaining screw.
4. Install the rear door handle bezel. Refer to **Handle Bezel Replacement - Inside - Rear** .
5. Install the upper door trim panel. Refer to **Trim Panel Replacement - Upper Extension** .

WATER DEFLECTOR REPLACEMENT - FRONT DOOR

Removal Procedure

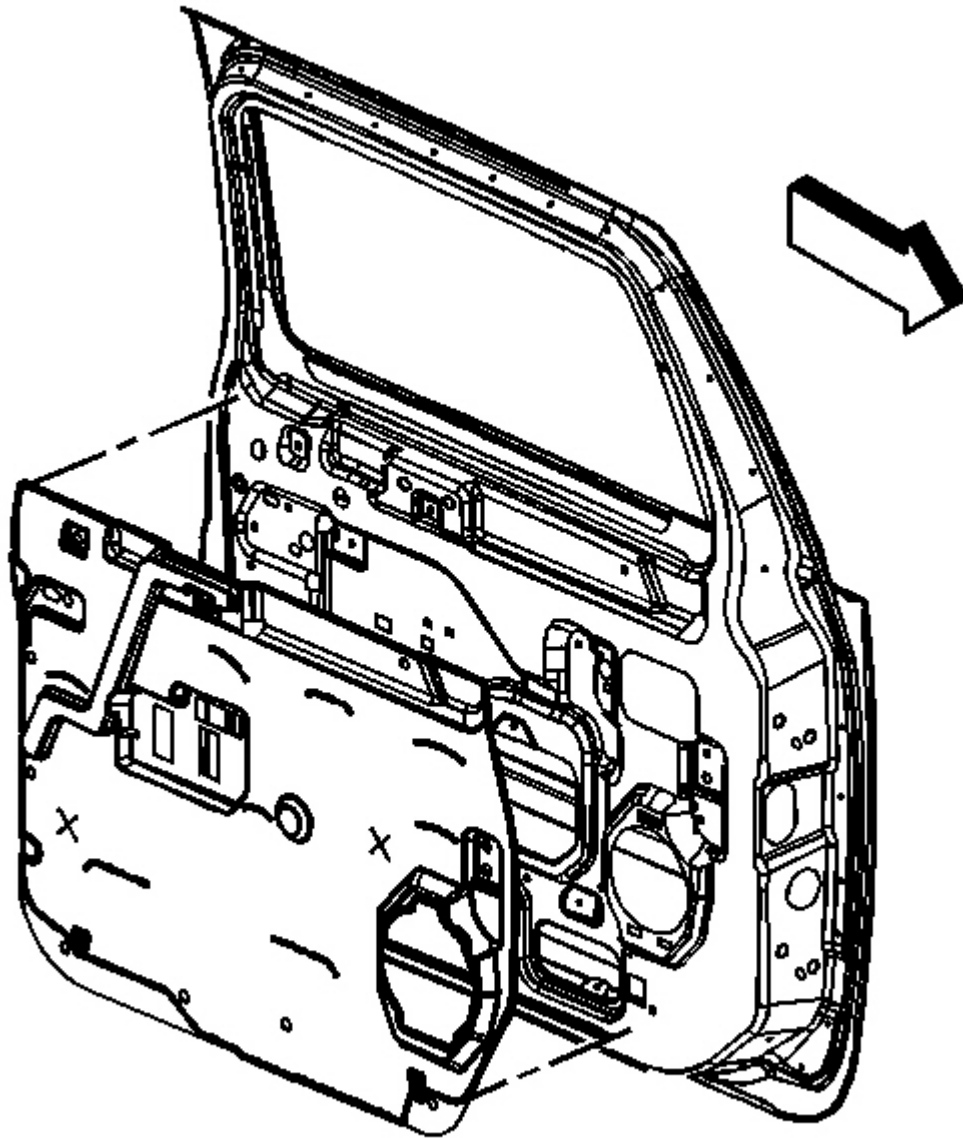

Fig. 32: Front Door Water Deflector
Courtesy of GENERAL MOTORS CORP.

IMPORTANT: Water deflectors seal the inner panel, preventing water from entering the door. A piece of adhesive between the deflector and the door secures the deflector.

1. Remove the trim panel. Refer to **Trim Panel Replacement - Side Front Door** .
2. Remove the inside door handle. Refer to **Door Handle Replacement - Front Inside** .
3. Using a flat-bladed tool, break the bond between the sealer and the door.
4. Remove the water deflector.

Installation Procedure

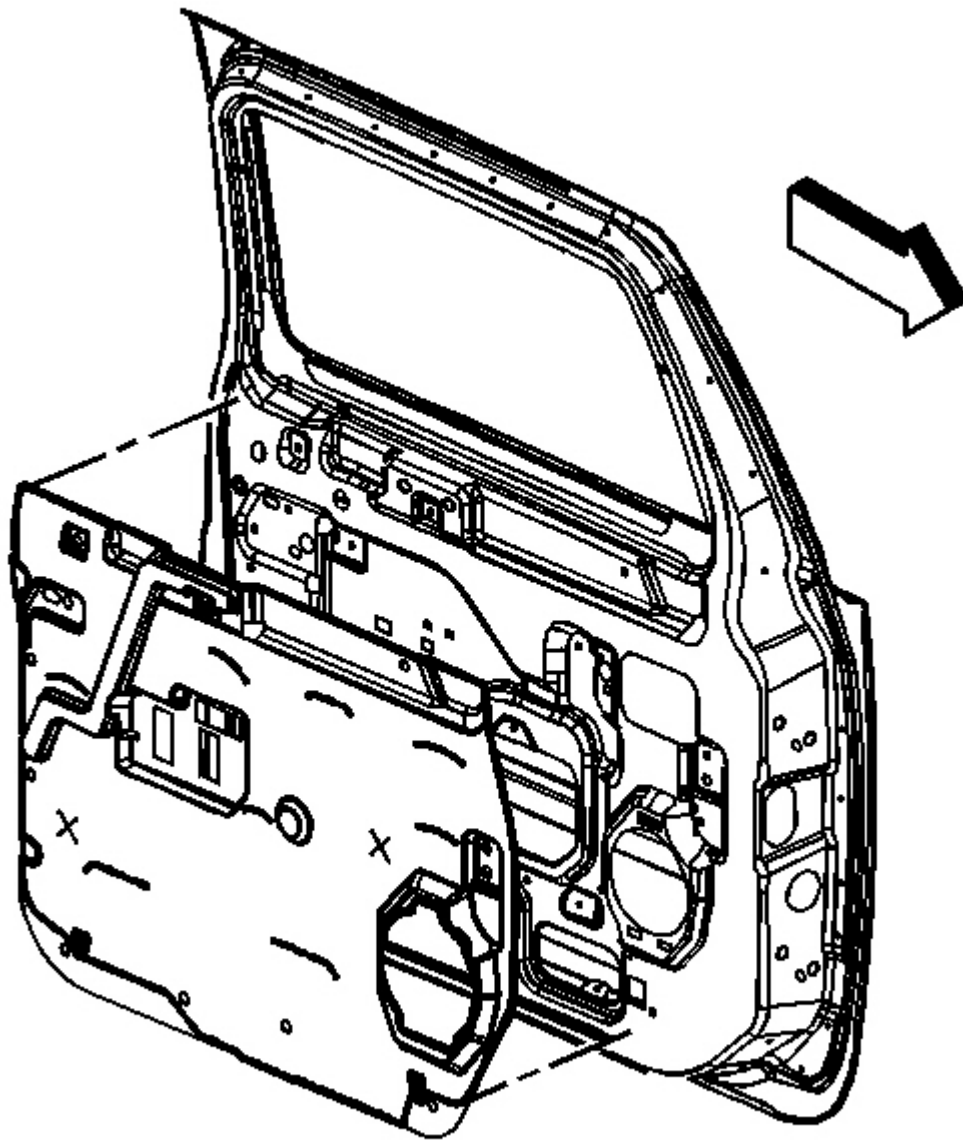

Fig. 33: Front Door Water Deflector
Courtesy of GENERAL MOTORS CORP.

1. Using a butyl style strip caulk sealer (3M P/N 051135-08578) or equivalent to seal the water deflector to the door, install the water deflector to the door.
2. Install the inside door handle. Refer to **Door Handle Replacement - Front Inside** .

3. Install the trim panel. Refer to **Trim Panel Replacement - Side Front Door** .

WATER DEFLECTOR REPLACEMENT - REAR DOOR

Removal Procedure

IMPORTANT: Water deflectors seal the inner panel, preventing water from entering the door. A piece of adhesive between the deflector and the door secures the deflector.

1. Remove the trim panel. Refer to **Trim Panel Replacement - Side Rear Door** .
2. Remove the inside door handle. Refer to **Door Handle Replacement - Rear Inside** .

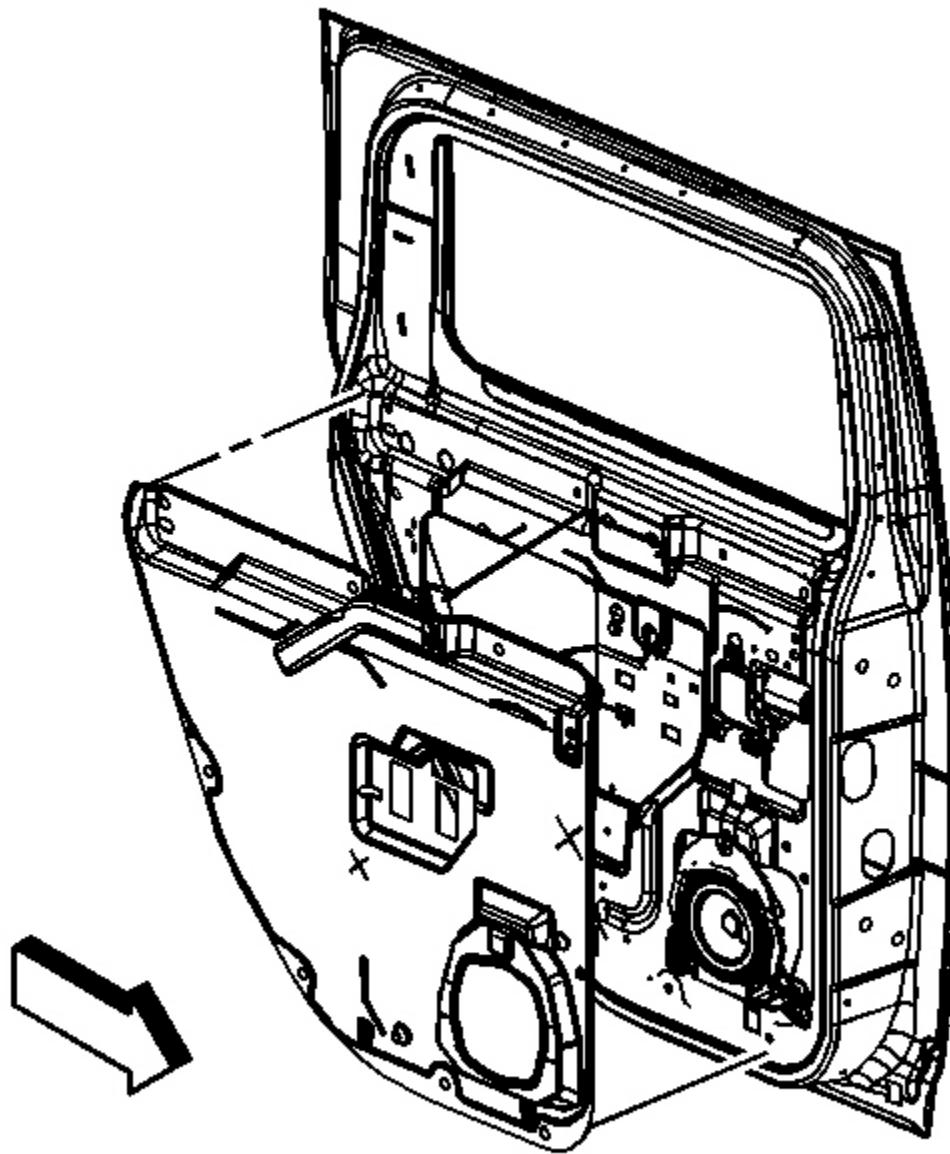

Fig. 34: Rear Door Water Deflector
Courtesy of GENERAL MOTORS CORP.

3. Using a flat-bladed tool, break the bond between the sealer and the door.
4. Remove the water deflector.

Installation Procedure

1. Install the inside door handle. Refer to Door Handle Replacement - Rear Inside .

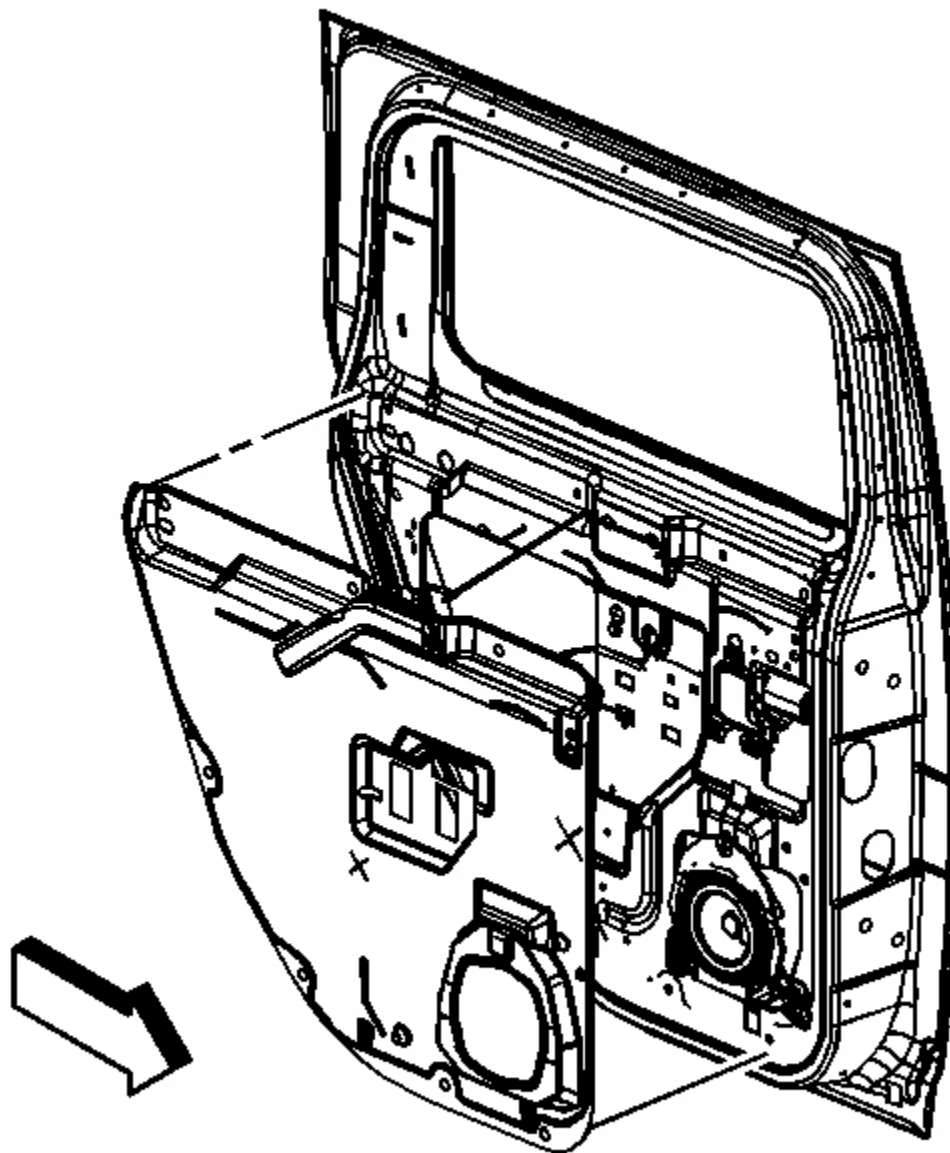

Fig. 35: Rear Door Water Deflector
Courtesy of GENERAL MOTORS CORP.

2. Using a butyl style strip caulk sealer (3M P/N 051135-08578) or equivalent, install the water deflector to the door.
3. Install the trim panel. Refer to **Trim Panel Replacement - Side Rear Door** .

DOOR ADJUSTMENT - FRONT

1. Loosen the door hinge bolts and adjust by moving the door:
 - Upward and downward
 - Forward and rearward
 - Inward or outward

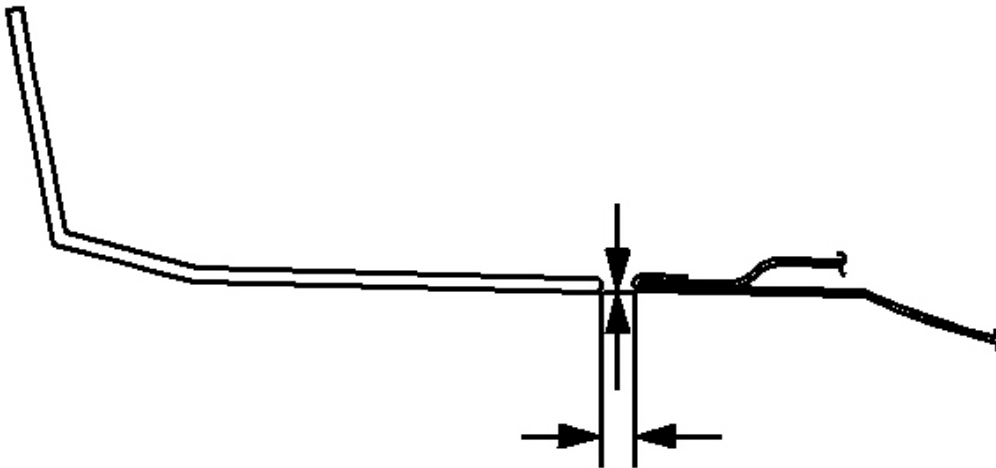

Fig. 36: Adjusting Front Door To Fender Gap
Courtesy of GENERAL MOTORS CORP.

2. Adjust the front door to fender gap to 5 mm (0.2 in).

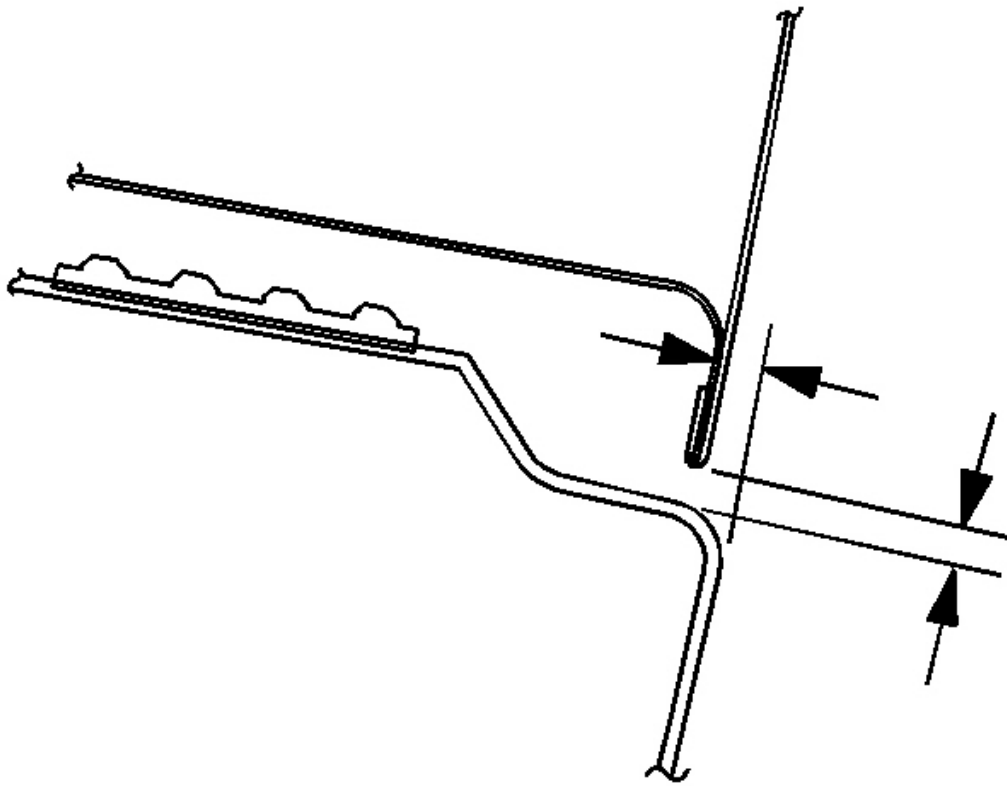

Fig. 38: Adjusting Front Door To Rocker Panel Gap
Courtesy of GENERAL MOTORS CORP.

4. Adjust the front door to rocker panel gap to 5 mm (0.2 in).

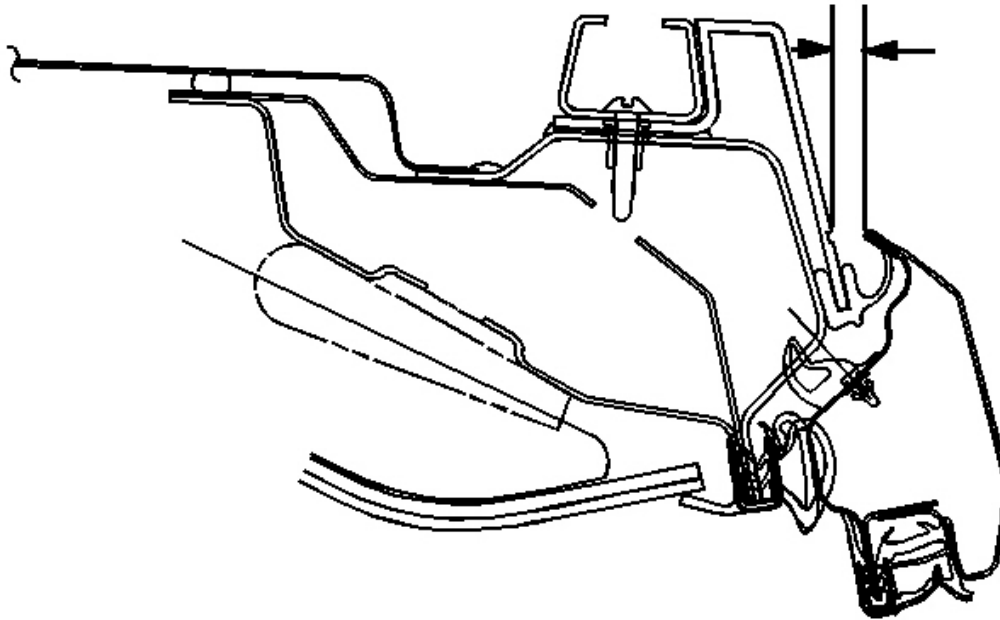

Fig. 39: Adjusting Front Door To Roof Gap
Courtesy of GENERAL MOTORS CORP.

5. Adjust the front door to roof gap to 8.6 mm (0.33 in).

NOTE: Refer to Fastener Notice in Cautions and Notices.

6. When proper adjustment specifications are set:

Tighten: Tighten the hinge bolts to 25 N.m (18 lb ft).

DOOR REPLACEMENT - FRONT

Removal Procedure

1. Remove the door trim panel. Refer to Trim Panel Replacement - Side Front Door .
2. Remove the water deflector. Refer to Water Deflector Replacement - Front Door .
3. Remove the wiring harness. Refer to Wiring Harness Replacement - Front Door .
4. Remove the fasteners retaining the door check link to the body. Refer to Door Check Link Replacement .

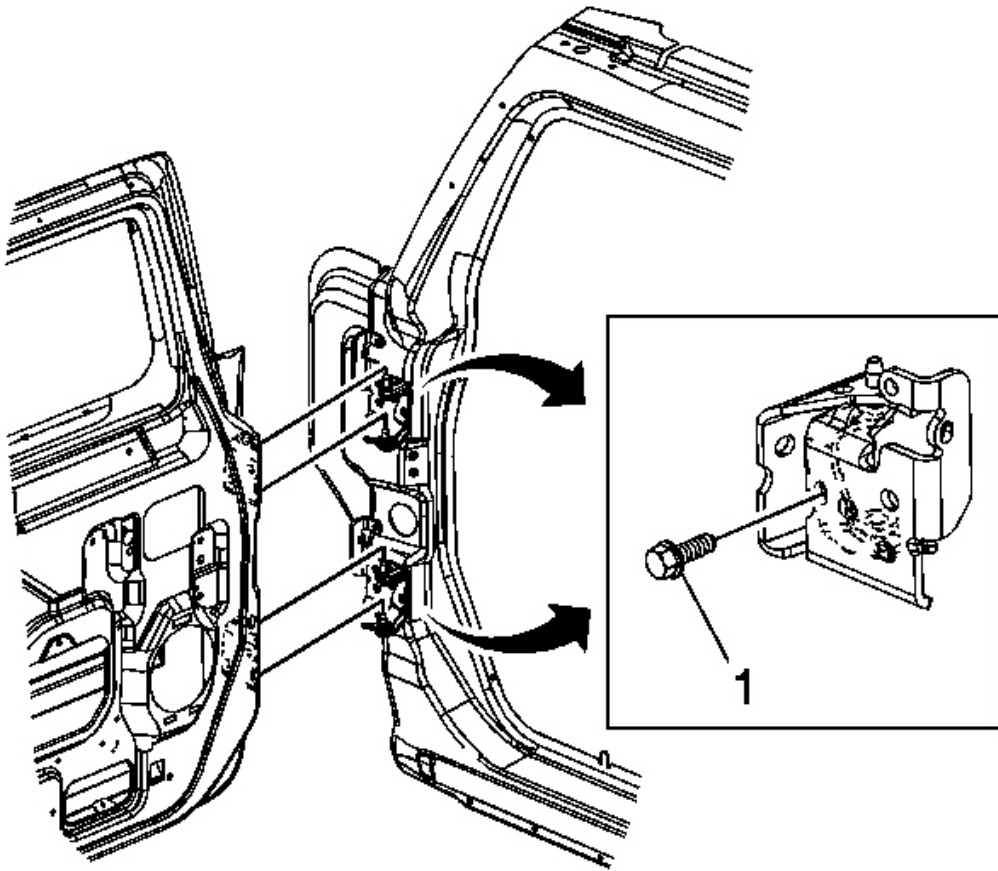

Fig. 40: Front Door Fastener
Courtesy of GENERAL MOTORS CORP.

5. Remove the fastener (1) retaining the door hinge halves together.
6. With an assistant, lift up on the door and remove the door from the vehicle.

Installation Procedure

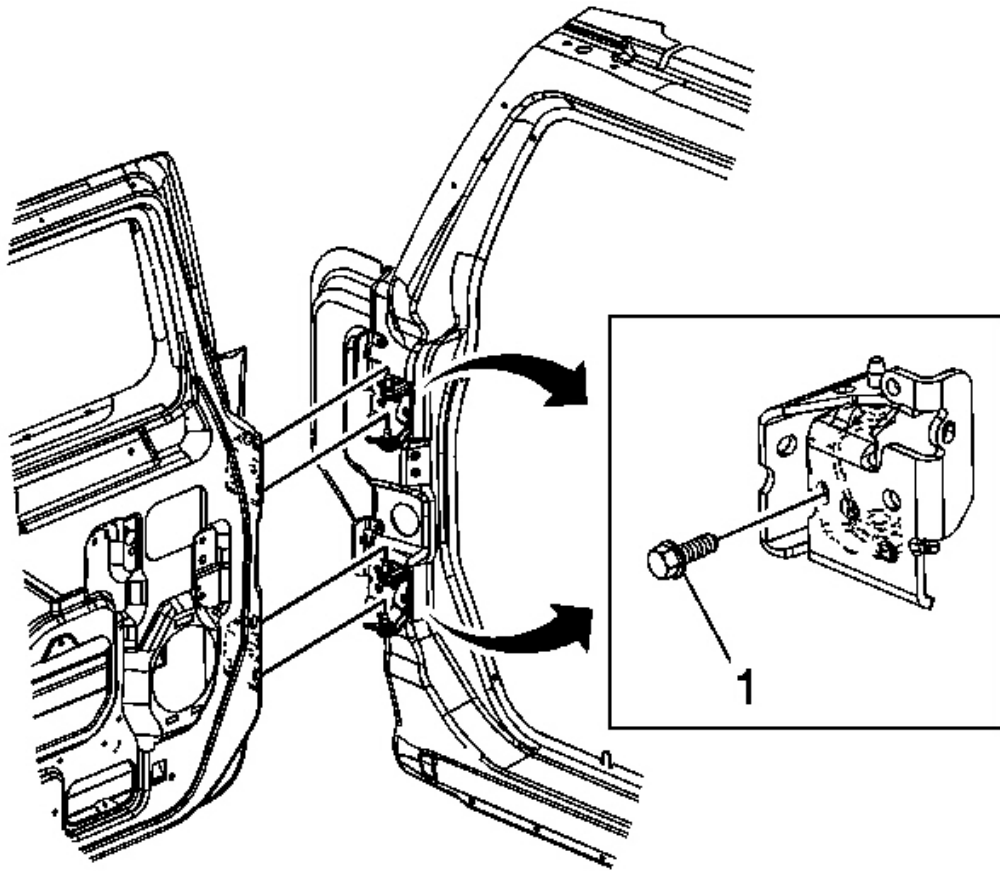

Fig. 41: Front Door Fastener
Courtesy of GENERAL MOTORS CORP.

NOTE: Refer to Fastener Notice in Cautions and Notices.

1. With an assistant, align the door to the vehicle and install the fastener (1) that retains the door hinge halves together.

Tighten: Tighten the fastener to 9 N.m (7 lb ft).

2. Transfer components as necessary.
3. Install the fasteners that retain the door check link to the body. Refer to Door Check Link Replacement.
4. Install the wiring harness. Refer to Wiring Harness Replacement - Front Door.

5. Install the water deflector. Refer to **Water Deflector Replacement - Front Door** .
6. Install the door trim panel. Refer to **Trim Panel Replacement - Side Front Door** .

DOOR ADJUSTMENT - REAR

1. Loosen the door hinge bolts and adjust the door by moving the door:
 - Upward or downward
 - Forward or rearward
 - Inward or outward

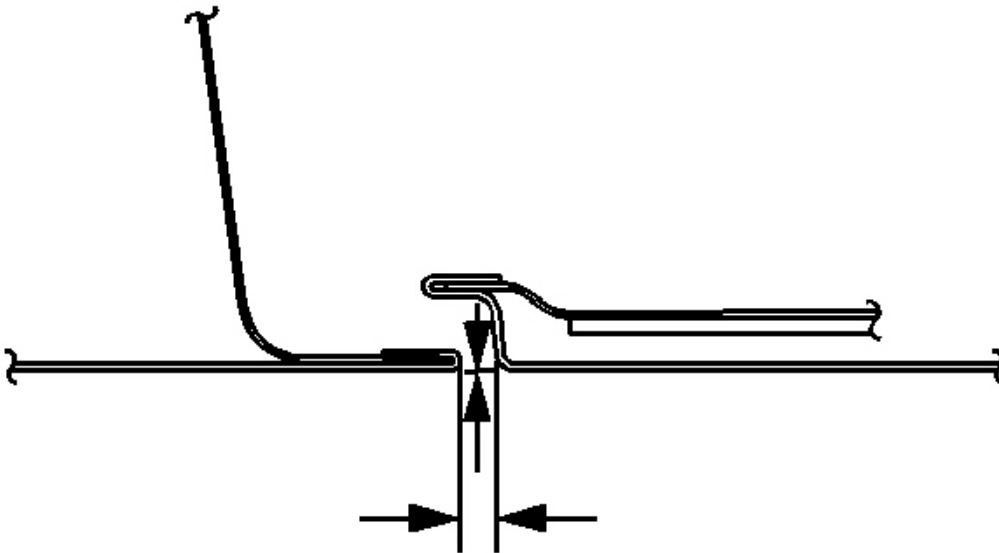

Fig. 42: Adjusting Rear Door To Front Door Gap
Courtesy of GENERAL MOTORS CORP.

2. Adjust the rear door to front door gap to 5 mm (0.2 in).

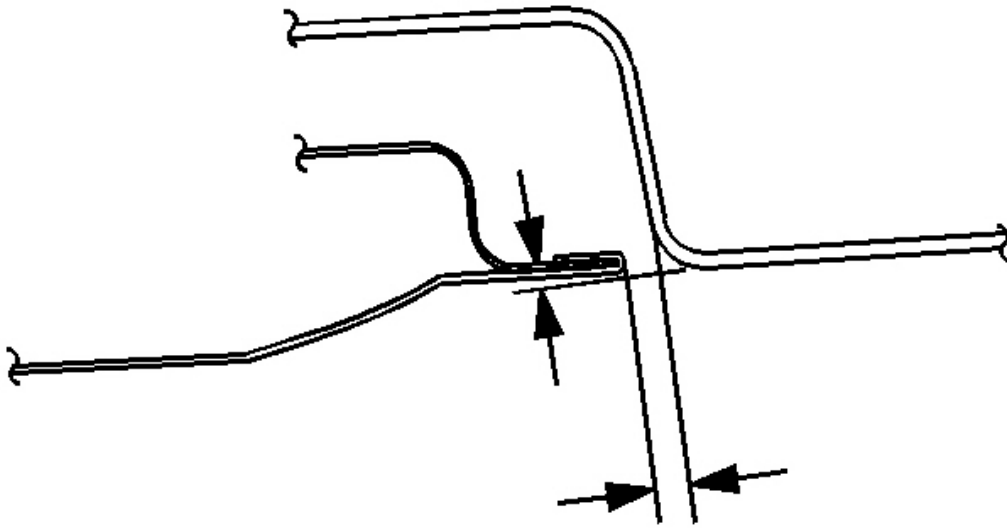

Fig. 43: Adjusting Rear Door To Body Side Panel
Courtesy of GENERAL MOTORS CORP.

3. Adjust the rear door to body side panel 5 mm (0.2 in).

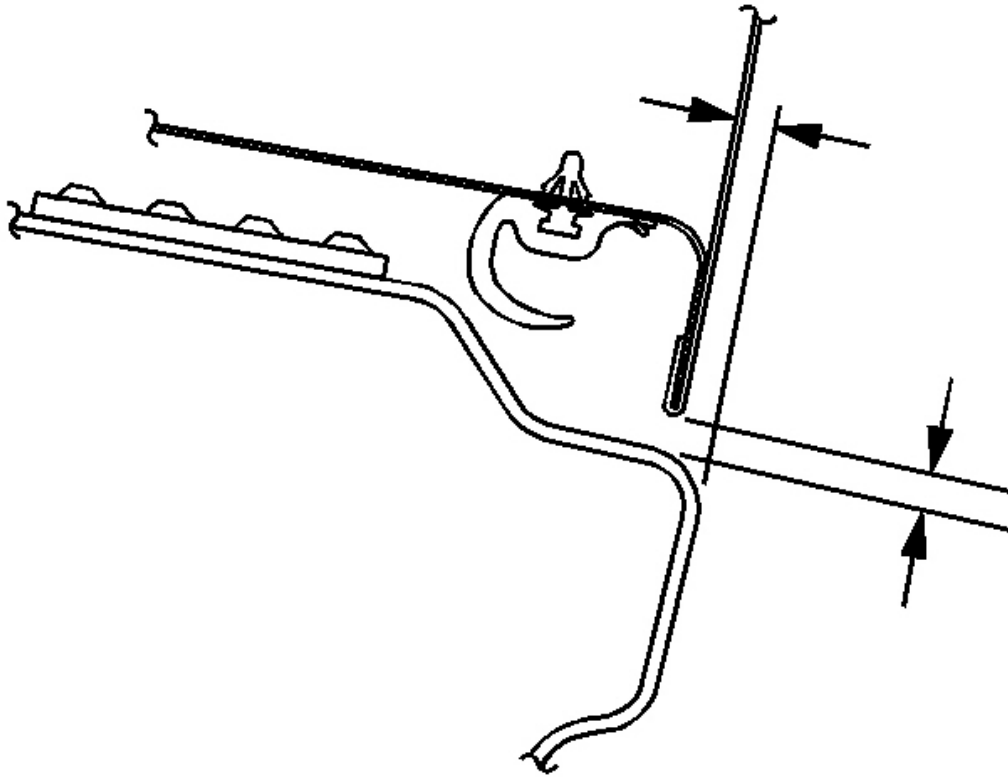

Fig. 44: Adjusting Rear Door To Rocker Panel Gap
Courtesy of GENERAL MOTORS CORP.

4. Adjust the rear door to rocker panel gap to 5 mm (0.2 in).

NOTE: Refer to Fastener Notice in Cautions and Notices.

5. When proper adjustment specifications are set,

Tighten: Tighten the hinge bolts to 25 N.m (18 lb ft).

DOOR REPLACEMENT - REAR

Removal Procedure

1. Remove the door trim panel. Refer to Trim Panel Replacement - Side Rear Door.
2. Remove the water deflector. Refer to Water Deflector Replacement - Rear Door.

3. Remove the wiring harness. Refer to **Wiring Harness Replacement - Rear Door** .
4. Remove the fasteners retaining the door check link to the body. Refer to **Door Check Link Replacement** .

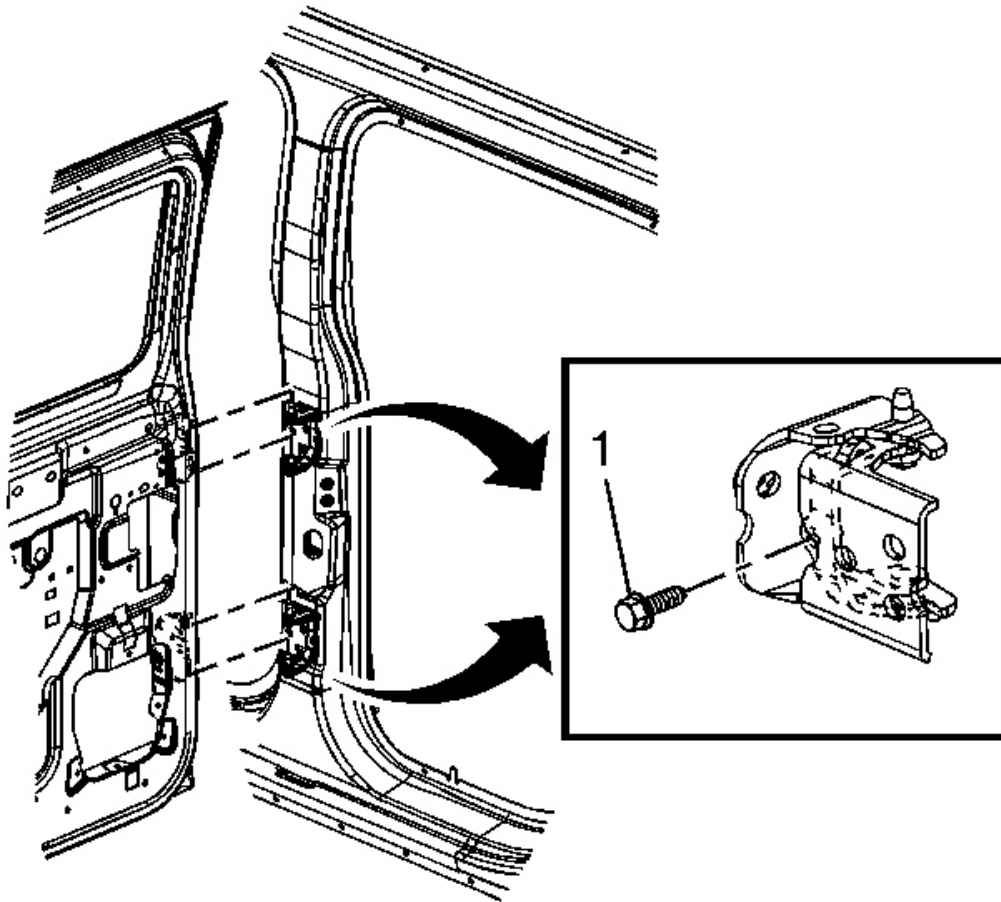

Fig. 45: Rear Door Fasteners
Courtesy of GENERAL MOTORS CORP.

5. Remove the fasteners (1) retaining the door hinge halves together.
6. With an assistant, lift up on the door and remove the door from the vehicle.

Installation Procedure

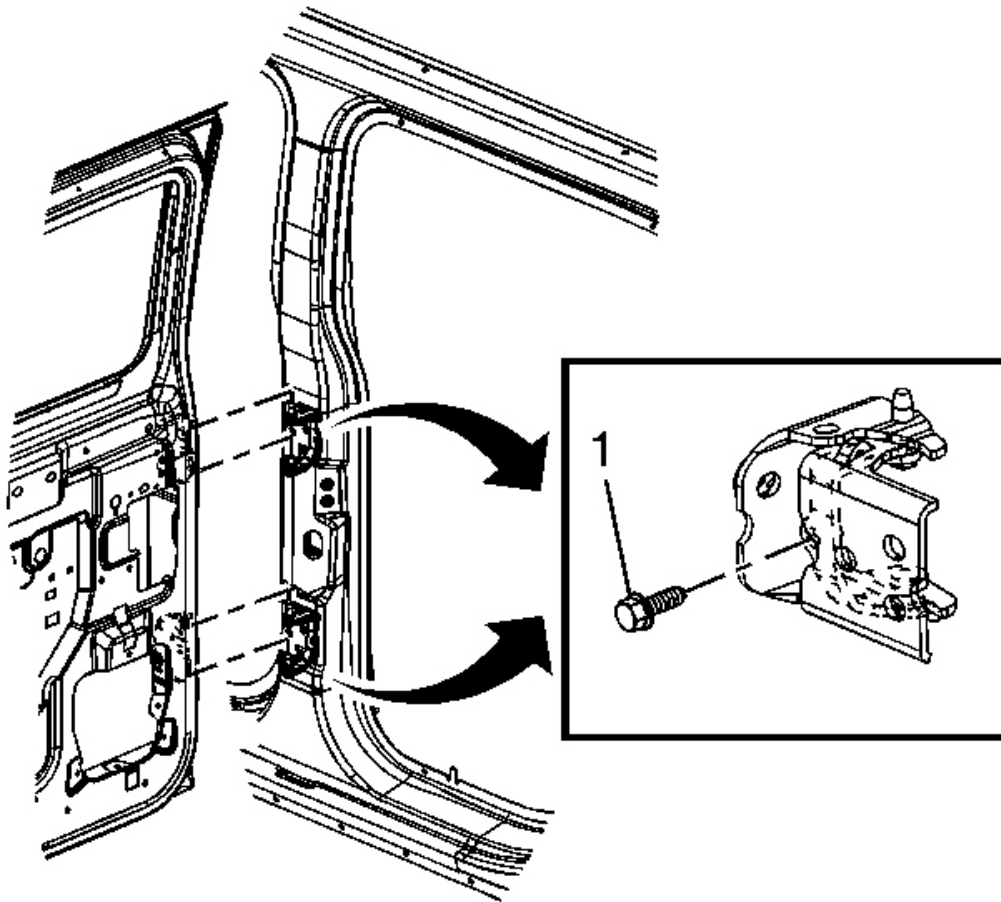

Fig. 46: Rear Door Fasteners
Courtesy of GENERAL MOTORS CORP.

1. With an assistant, align the door to the vehicle and install the fasteners (1) that retain the door hinge halves together.

NOTE: Refer to Fastener Notice in Cautions and Notices

2. Install the fasteners that retain the door check link to the body. Refer to Door Check Link Replacement .

Tighten: Tighten the fasteners to 9 N.m (7 lb ft)

3. Install the wiring harness. Refer to Wiring Harness Replacement - Rear Door .

4. Transfer components as necessary.
5. Install the water deflector. Refer to Water Deflector Replacement - Rear Door .
6. Install the door trim panel. Refer to Trim Panel Replacement - Side Rear Door .

HINGE REPLACEMENT - FRONT DOOR

Removal Procedure

IMPORTANT: To retain proper alignment, properly support the door and replace the hinges one at a time if possible.

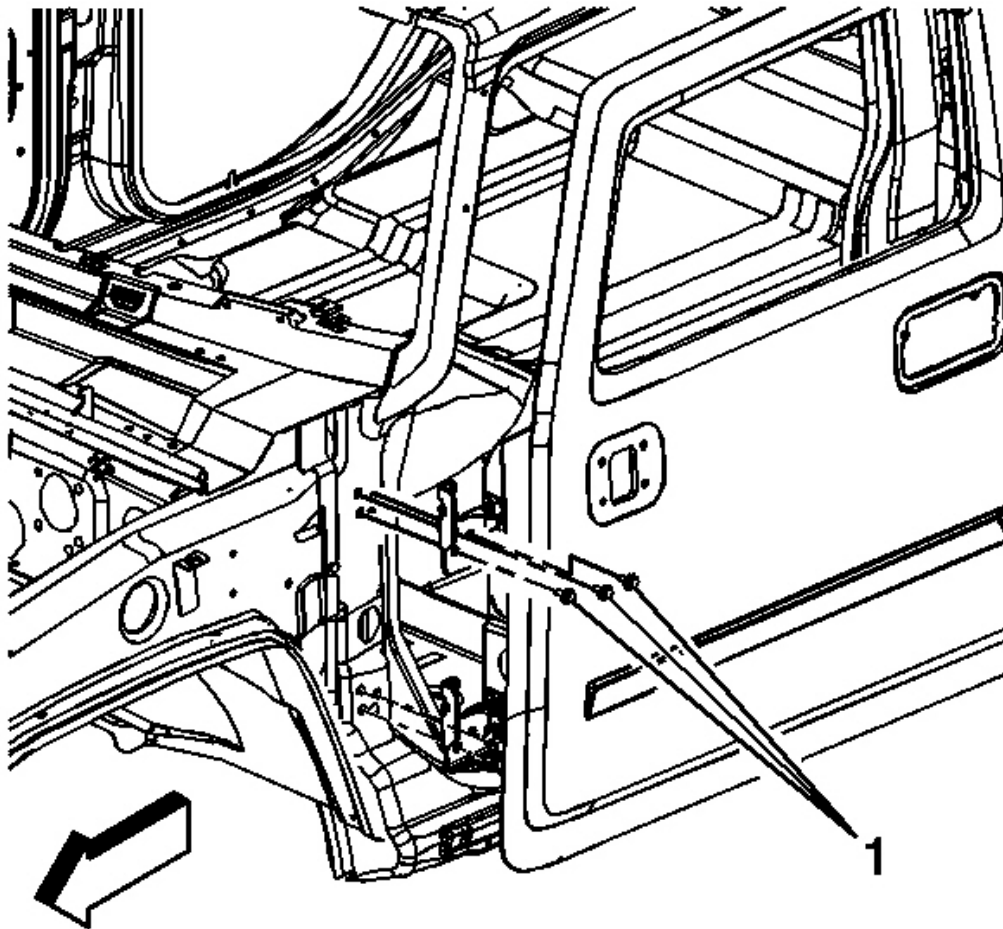

Fig. 47: Vehicle Fasteners
Courtesy of GENERAL MOTORS CORP.

1. Open the door.
2. Mark the hinge location with a grease pencil prior to removal.
3. Remove the 3 fasteners (1) retaining the hinge to the vehicle.

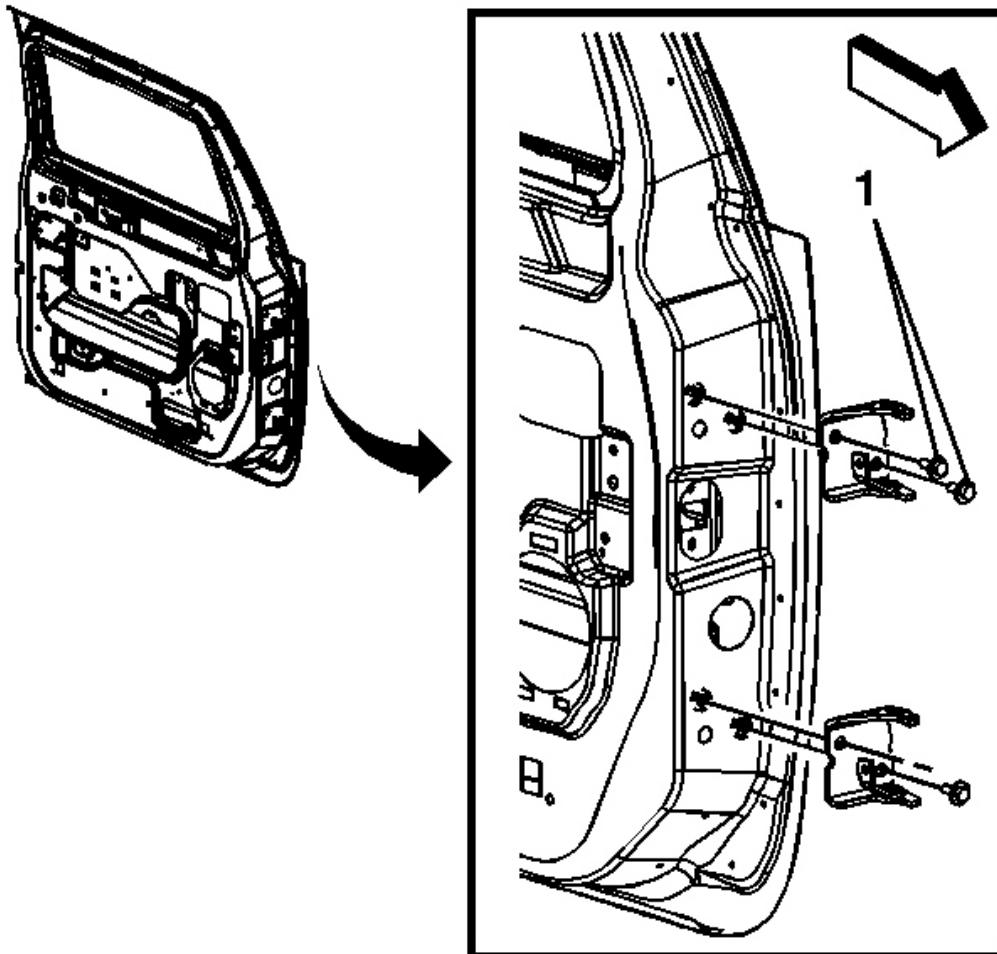

Fig. 48: Front Door Hinge Fasteners
Courtesy of GENERAL MOTORS CORP.

4. Remove the 2 fasteners (1) retaining the hinge to the door.
5. Remove the hinge.

1. With an assistant, align the hinge to the alignment marks made with the grease pencil.

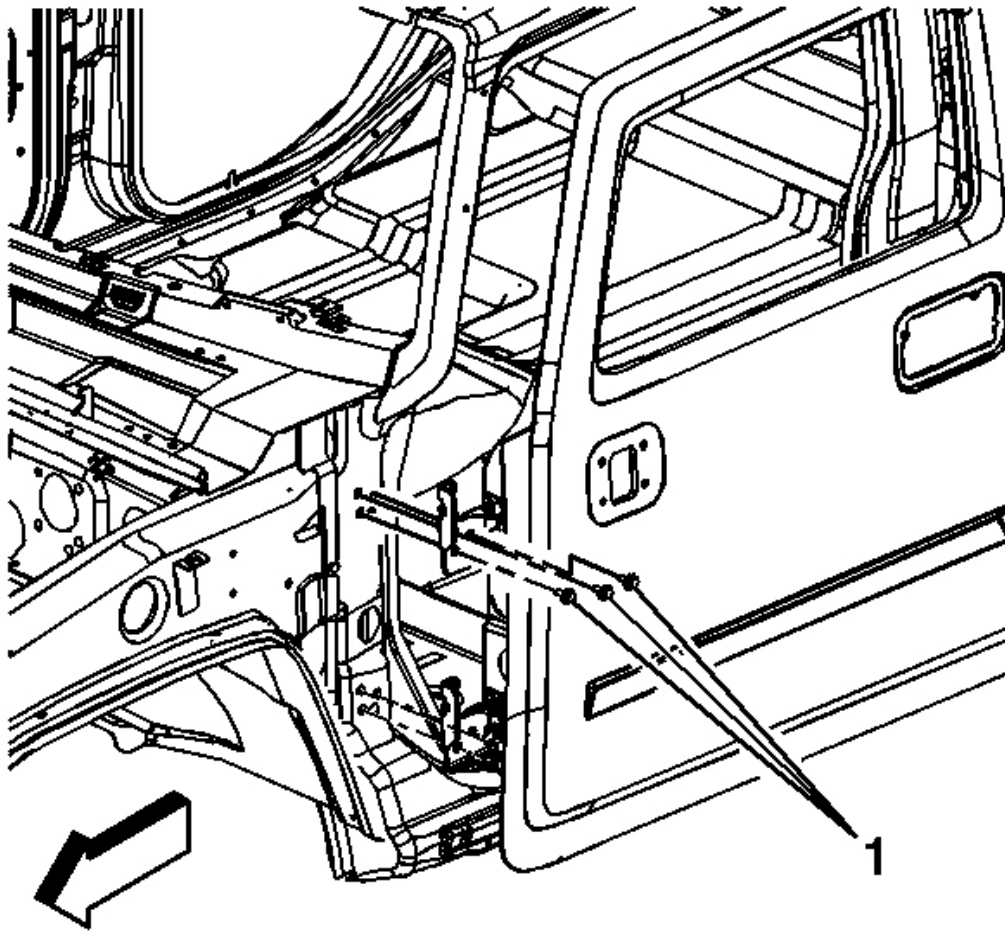

Fig. 49: Vehicle Hinge Fasteners
Courtesy of GENERAL MOTORS CORP.

NOTE: Refer to **Fastener Notice** in **Cautions and Notices**.

2. Install the fasteners (1) retaining the hinge to the vehicle.

Tighten: Tighten the fasteners to 25 N.m (18 lb ft).

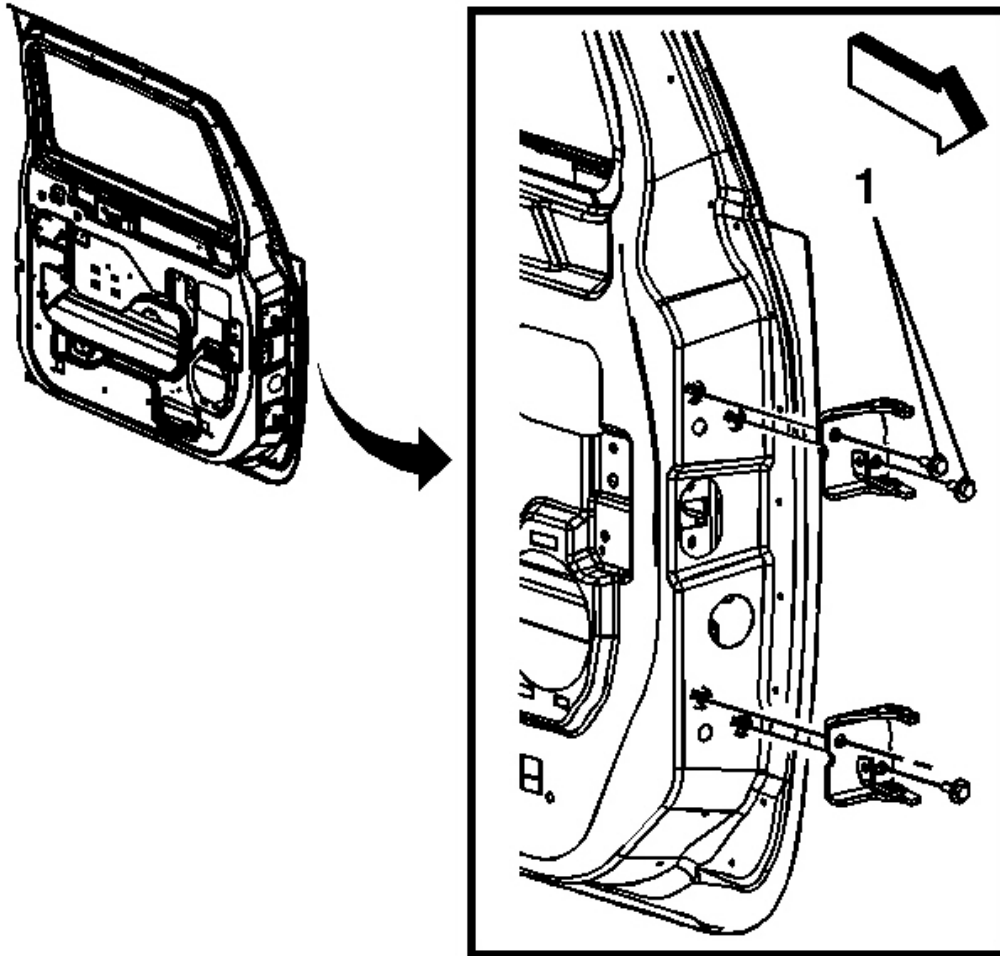

Fig. 50: Front Door Hinge Fasteners
Courtesy of GENERAL MOTORS CORP.

3. Install the fasteners (1) retaining the hinge to the door.

Tighten: Tighten the fasteners to 25 N.m (18 lb ft).

4. Adjust the door if necessary. Refer to **Door Adjustment - Front** .

HINGE REPLACEMENT - REAR DOOR

Removal Procedure

IMPORTANT: To retain proper alignment, properly support the door and replace the hinges one at a time if possible.

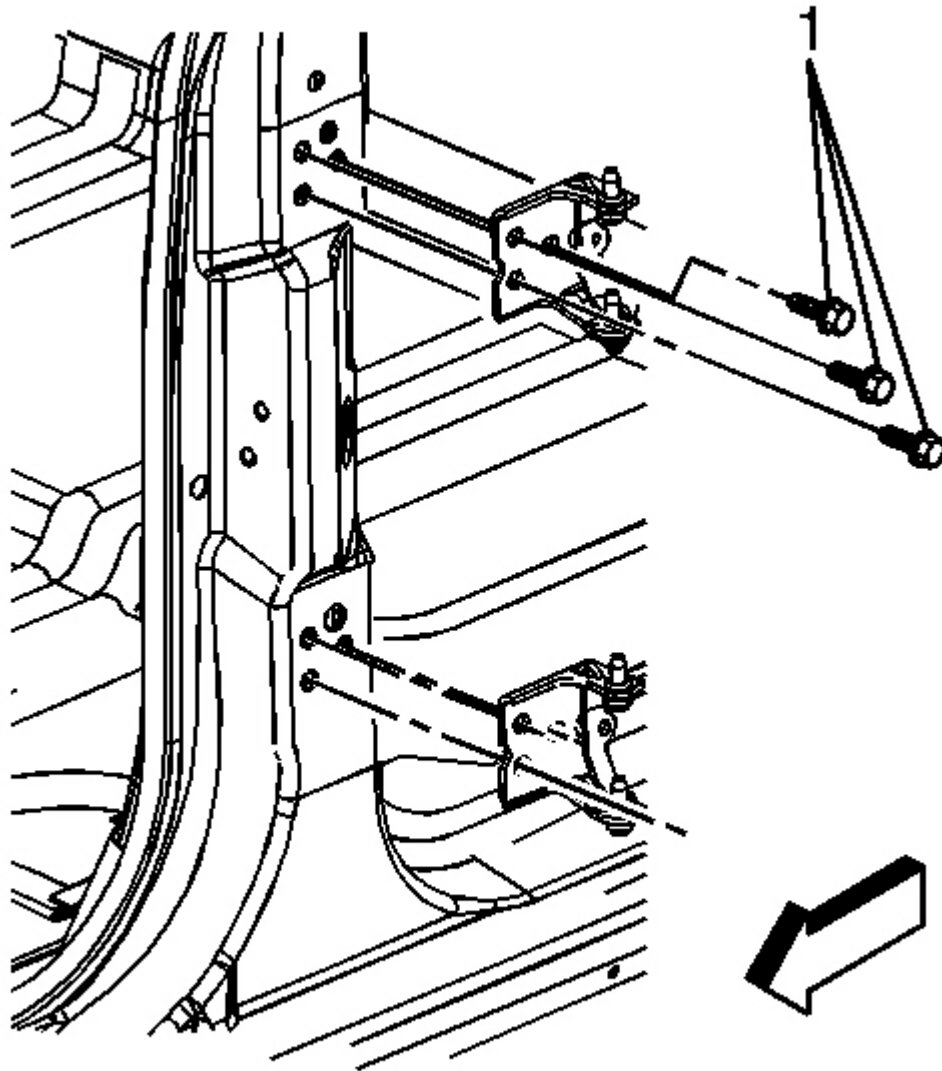

Fig. 51: Vehicle Hinge Fasteners
Courtesy of GENERAL MOTORS CORP.

1. Open the door.
2. Mark the hinge location with a grease pencil prior to removal.

3. Remove the 3 fasteners (1) retaining the hinge to the vehicle.

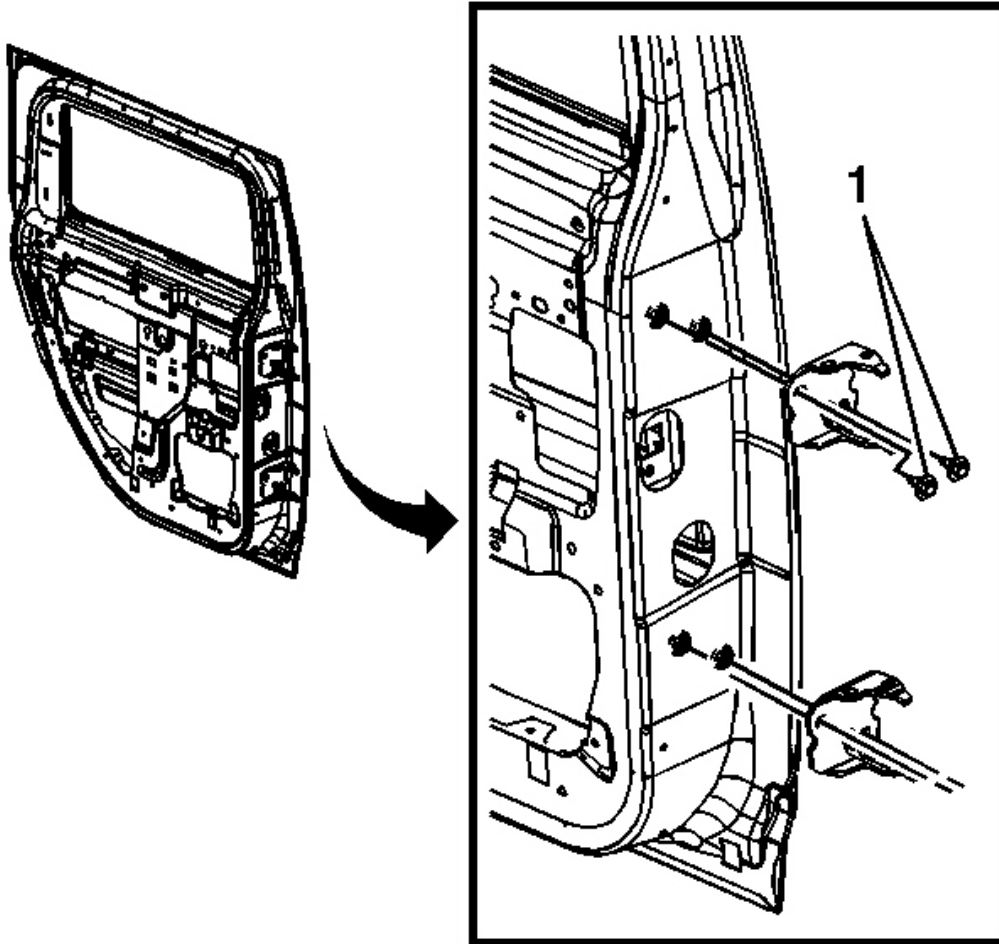

Fig. 52: Rear Door Hinge Fasteners
Courtesy of GENERAL MOTORS CORP.

4. Remove the 2 fasteners (1) retaining the hinge to the door.
5. Remove the hinge.

Installation Procedure

1. With an assistant, align the hinge to the alignment marks made with the grease pencil.

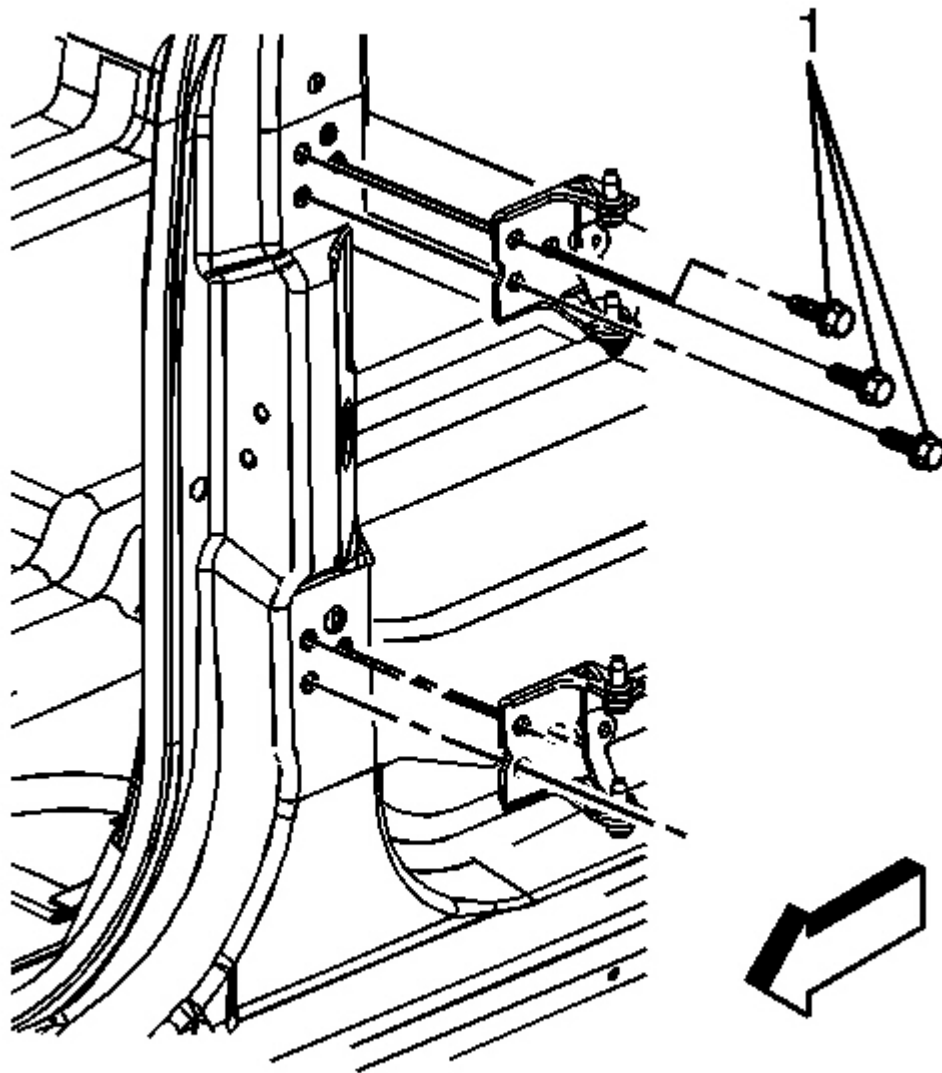

Fig. 53: Vehicle Hinge Fasteners
Courtesy of GENERAL MOTORS CORP.

NOTE: Refer to Fastener Notice in Cautions and Notices.

2. Install the fasteners (1) retaining the hinge to the vehicle.

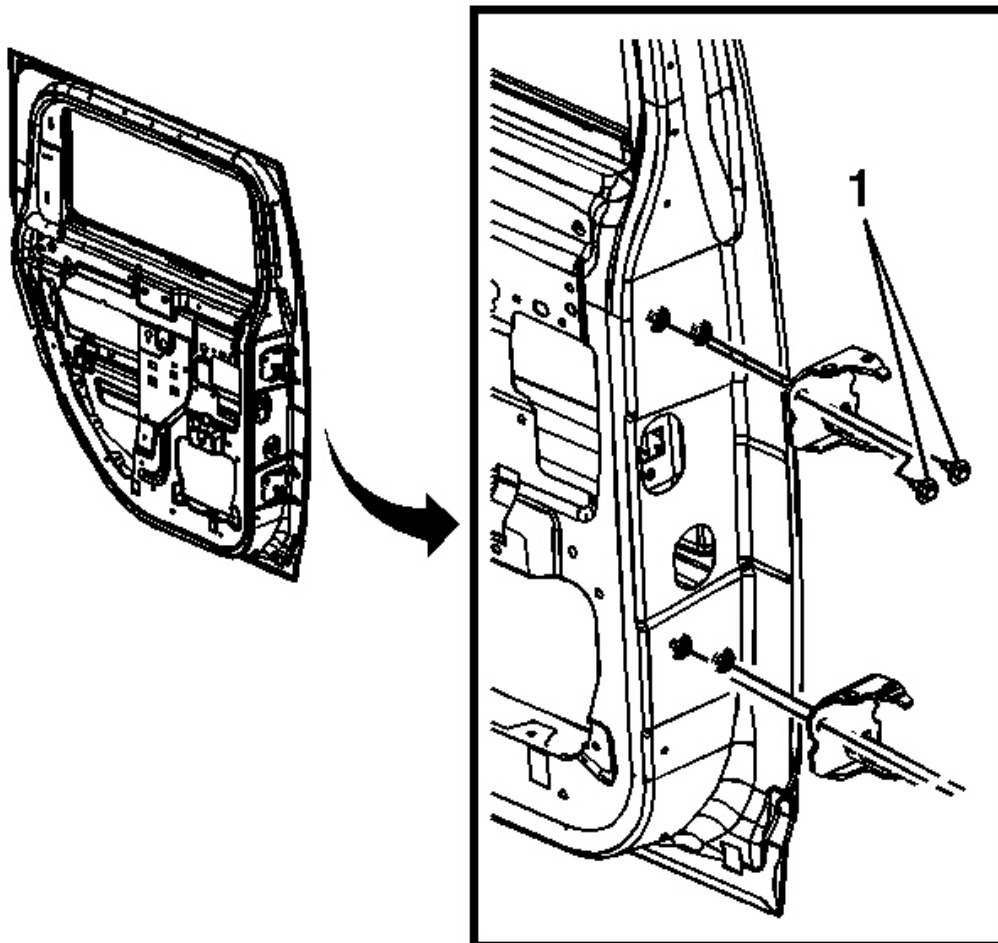

Fig. 54: Rear Door Hinge Fasteners
Courtesy of GENERAL MOTORS CORP.

3. Install the fasteners (1) retaining the hinge to the door.

Tighten: Tighten the fasteners to 25 N.m (18 lb ft).

4. Adjust the door if necessary. Refer to **Door Adjustment - Rear** .

DOOR CHECK LINK REPLACEMENT

Removal Procedure

1. Open the door.
2. Remove the door trim panel. Refer to Trim Panel Replacement - Side Front Door or Trim Panel Replacement - Side Rear Door .
3. Remove the water deflector. Refer to Water Deflector Replacement - Front Door or Water Deflector Replacement - Rear Door .

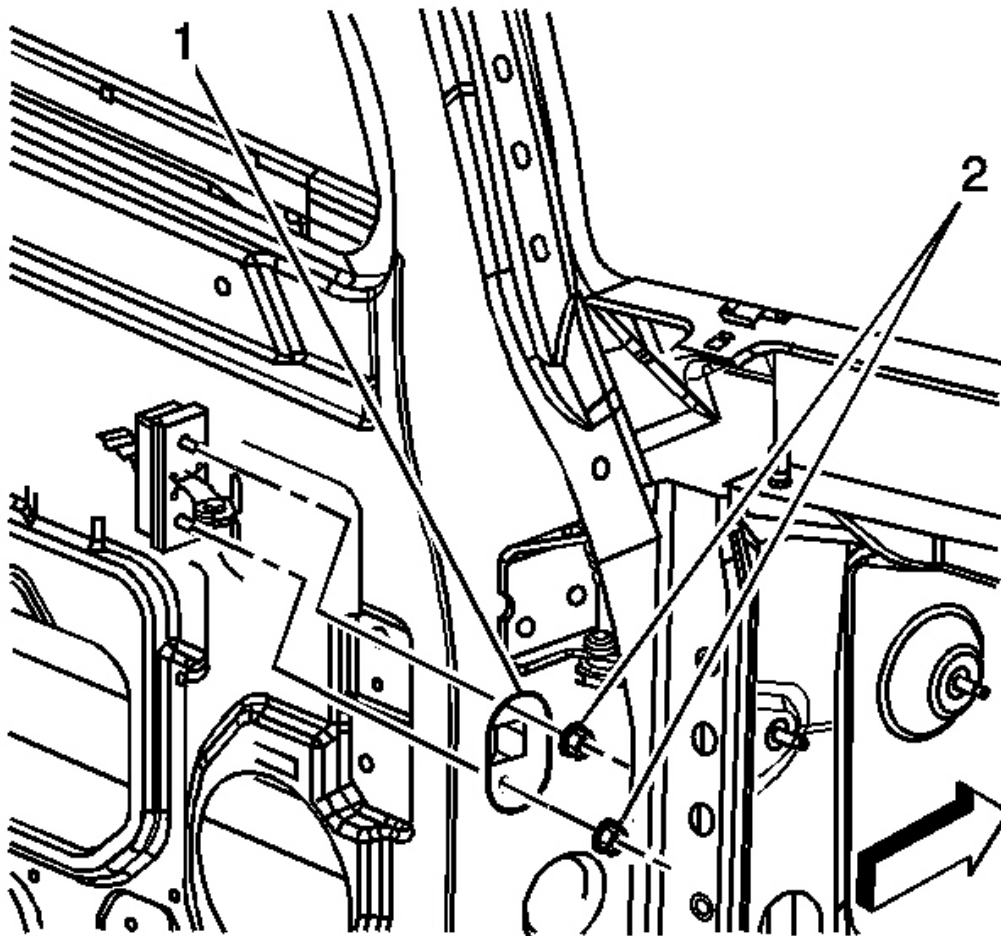

Fig. 55: Rubber Grommet & Front Door Check Link Opening
Courtesy of GENERAL MOTORS CORP.

4. Remove the rubber grommet in the door check link opening (1).
5. Remove the 2 nuts (2) retaining the check link to the door.

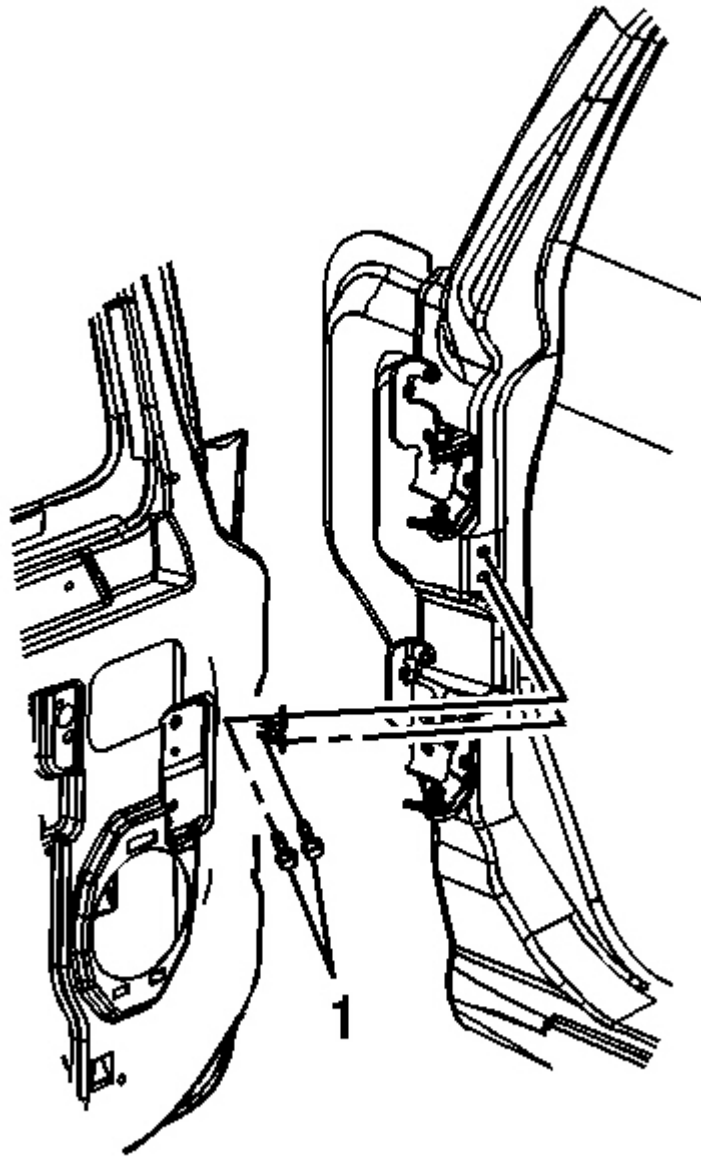

Fig. 56: Front Door Check Link Fasteners
Courtesy of GENERAL MOTORS CORP.

6. Remove the 2 fasteners (1) retaining the check link to the vehicle.
7. Remove the check link.

Installation Procedure

1. Place the check link in position in the door.

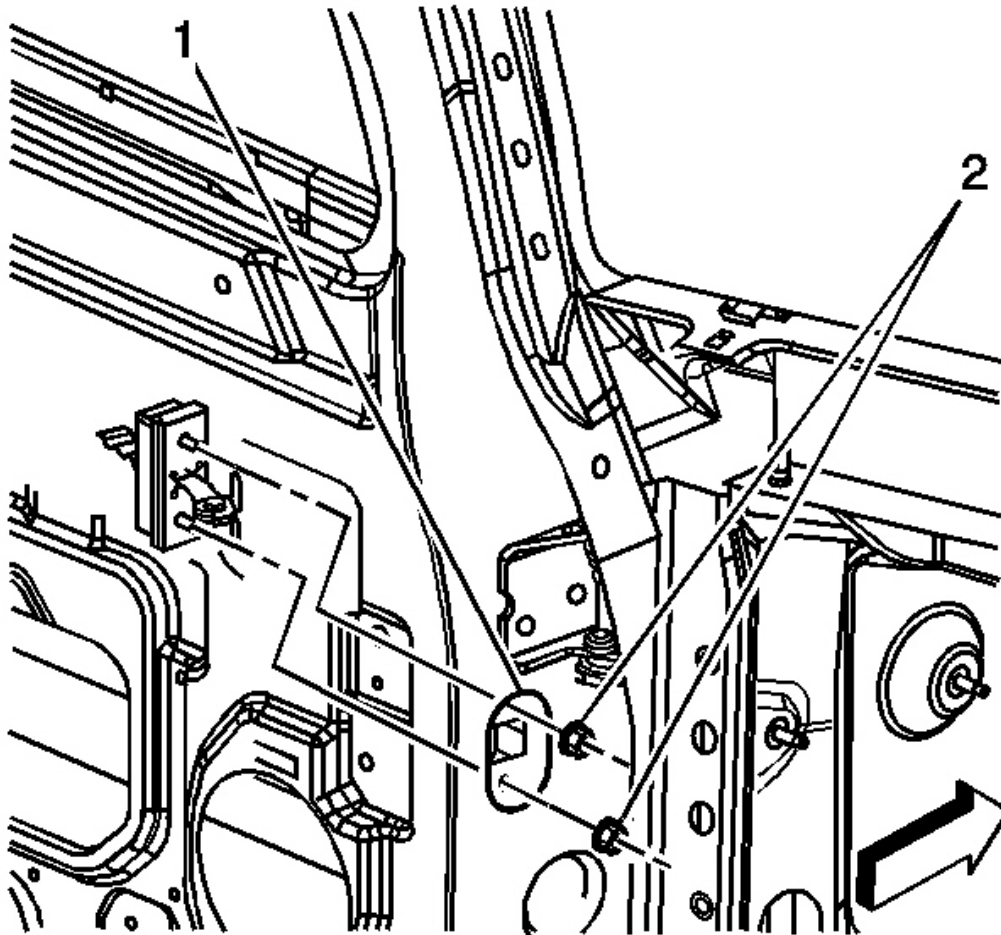

Fig. 57: Rubber Grommet & Front Door Check Link Opening
Courtesy of GENERAL MOTORS CORP.

NOTE: Refer to Fastener Notice in Cautions and Notices.

2. Install the nuts (2) that retain the check link to the door.

Tighten: Tighten the nuts to 9 N.m (7 lb ft).

3. Replace the rubber grommet in the door check link opening (1).

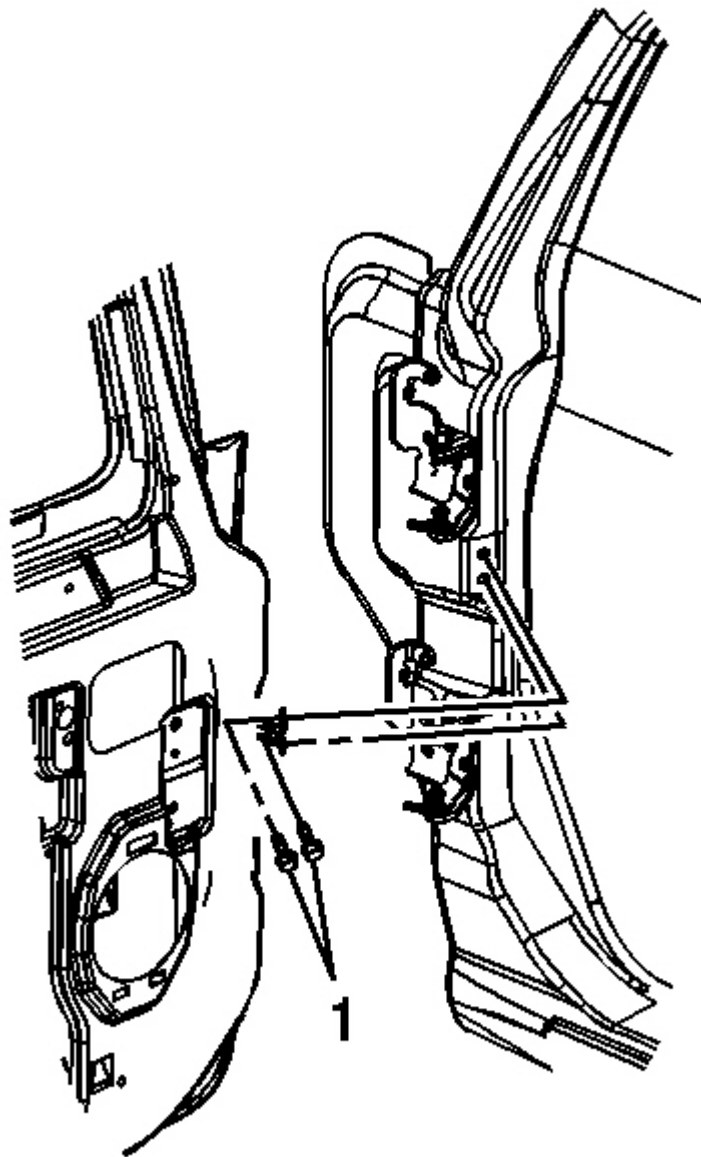

Fig. 58: Front Door Check Link Fasteners
Courtesy of GENERAL MOTORS CORP.

4. Install the fasteners (1) that retain the check link to the vehicle.

Tighten: Tighten the fasteners to 9 N.m (7 lb ft).

5. Install the water deflector. Refer to **Water Deflector Replacement - Front Door** or **Water Deflector Replacement - Rear Door** .
6. Install door trim panel. Refer to **Trim Panel Replacement - Side Front Door** or **Trim Panel Replacement - Side Rear Door** .

DOOR HANDLE REPLACEMENT - FRONT OUTSIDE

Removal Procedure

1. Remove the door trim panel. Refer to **Trim Panel Replacement - Side Front Door** .
2. Remove the water deflector. Refer to **Water Deflector Replacement - Front Door** .
3. Remove the window. Refer to **Window Replacement - Front Door** .

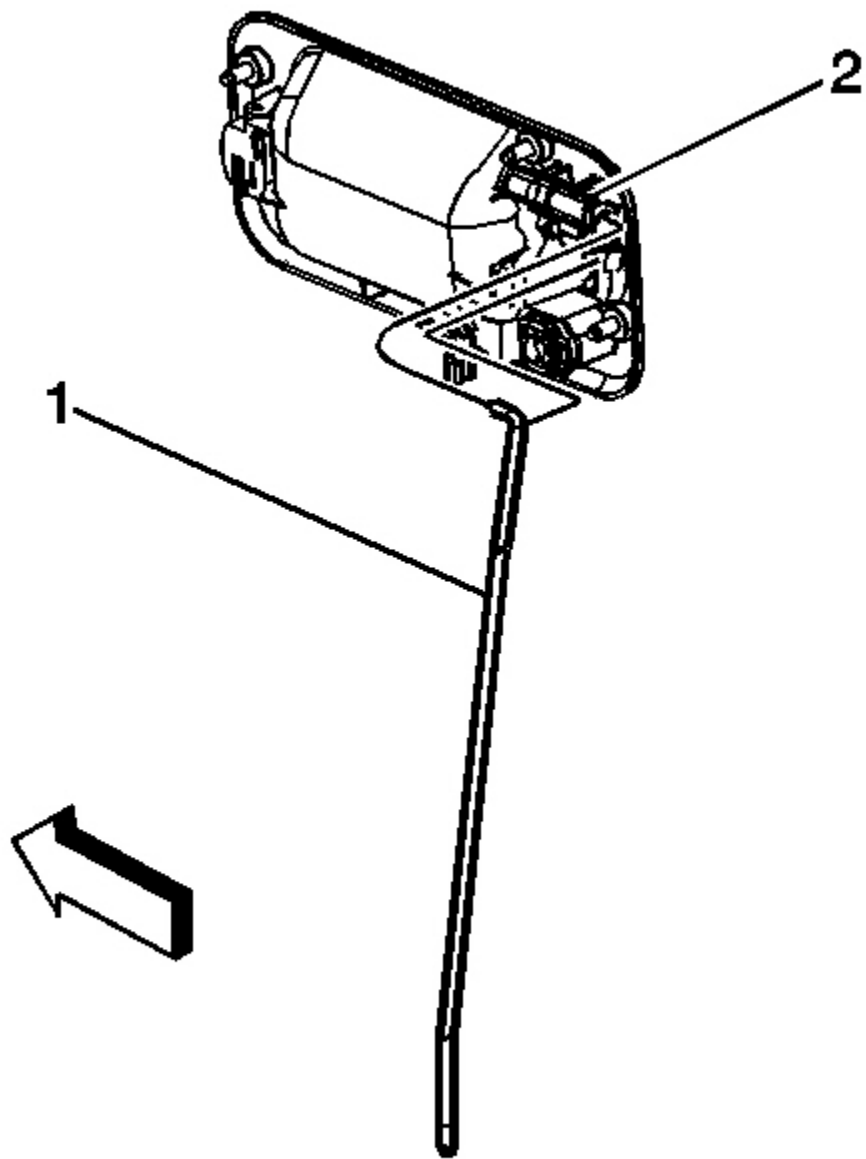

Fig. 59: Front Outside Door Handle Rod
Courtesy of GENERAL MOTORS CORP.

4. Disconnect the outside door handle rod (1) by releasing the retaining clip (2).

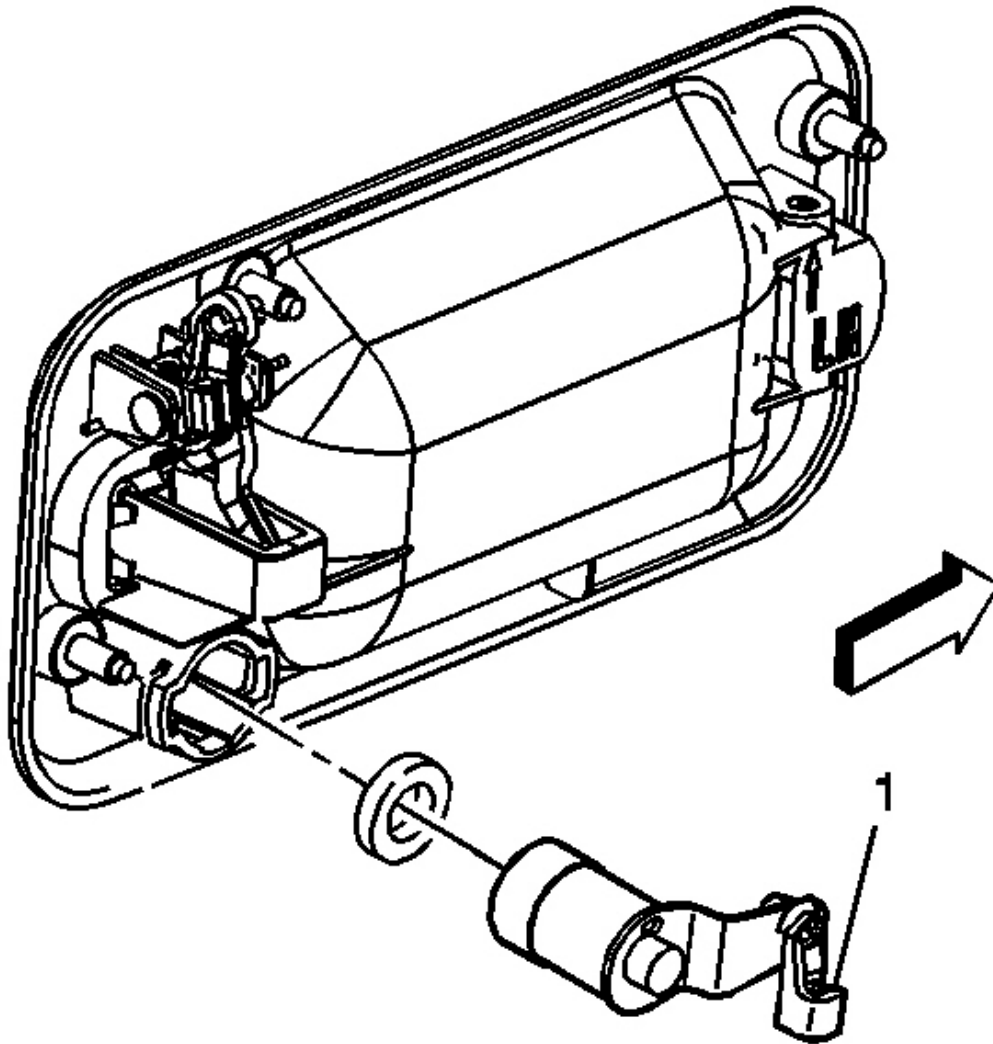

Fig. 60: Lock Cylinder Rod
Courtesy of GENERAL MOTORS CORP.

5. Disconnect the lock cylinder rod (1) by releasing the retainer clip.
6. Apply a piece of masking tape across the door handle, on the outside of the door, to secure the handle while removing the fasteners.

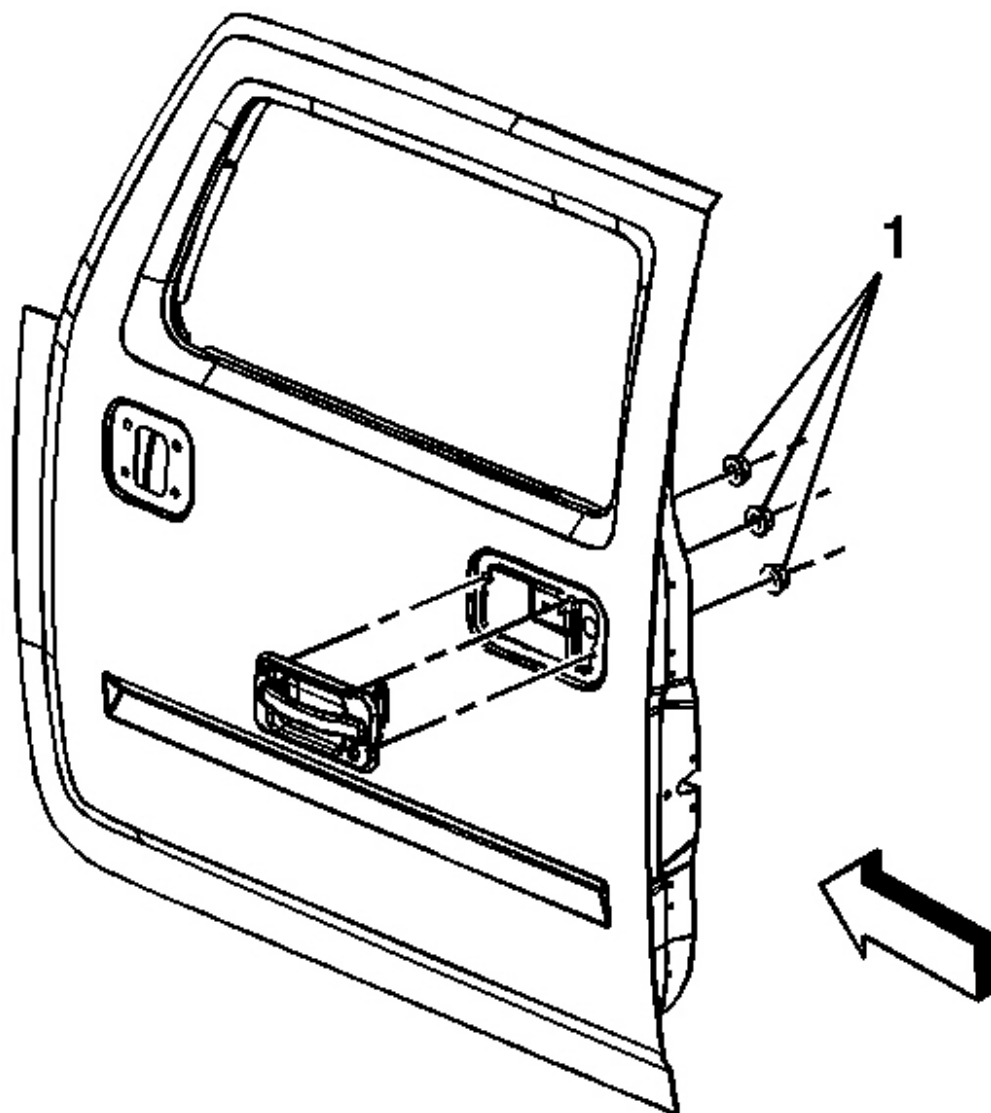

Fig. 61: Front Outside Door Handle
Courtesy of GENERAL MOTORS CORP.

7. Remove the 3 nuts (1) retaining the door handle.
8. Remove the door handle.

Installation Procedure

1. Position the door handle in place on the door.

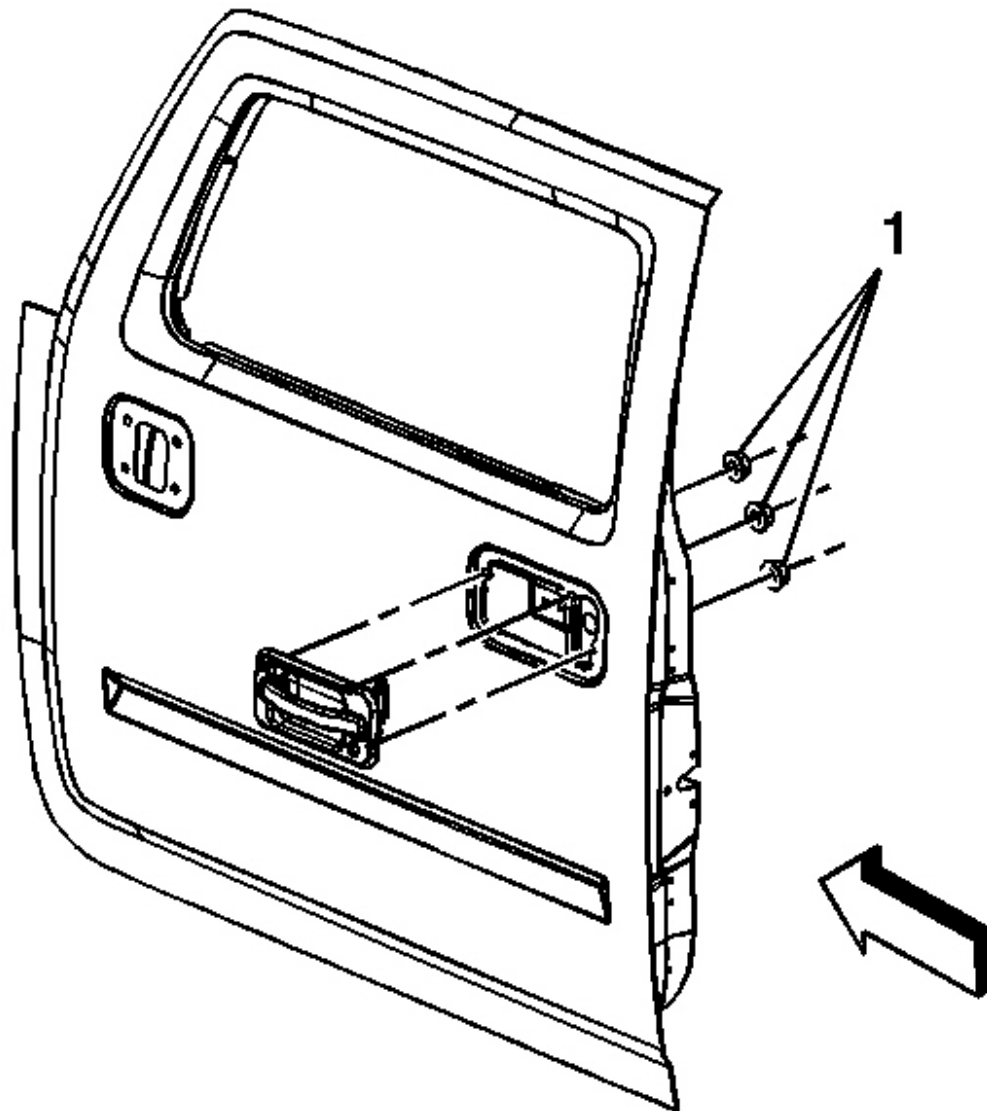

Fig. 62: Front Outside Door Handle
Courtesy of GENERAL MOTORS CORP.

NOTE: Refer to Fastener Notice in Cautions and Notices.

2. Install the 3 nuts (1) that retain the door handle to the door.

Tighten: Tighten the nuts to 9 N.m (7 lb ft).

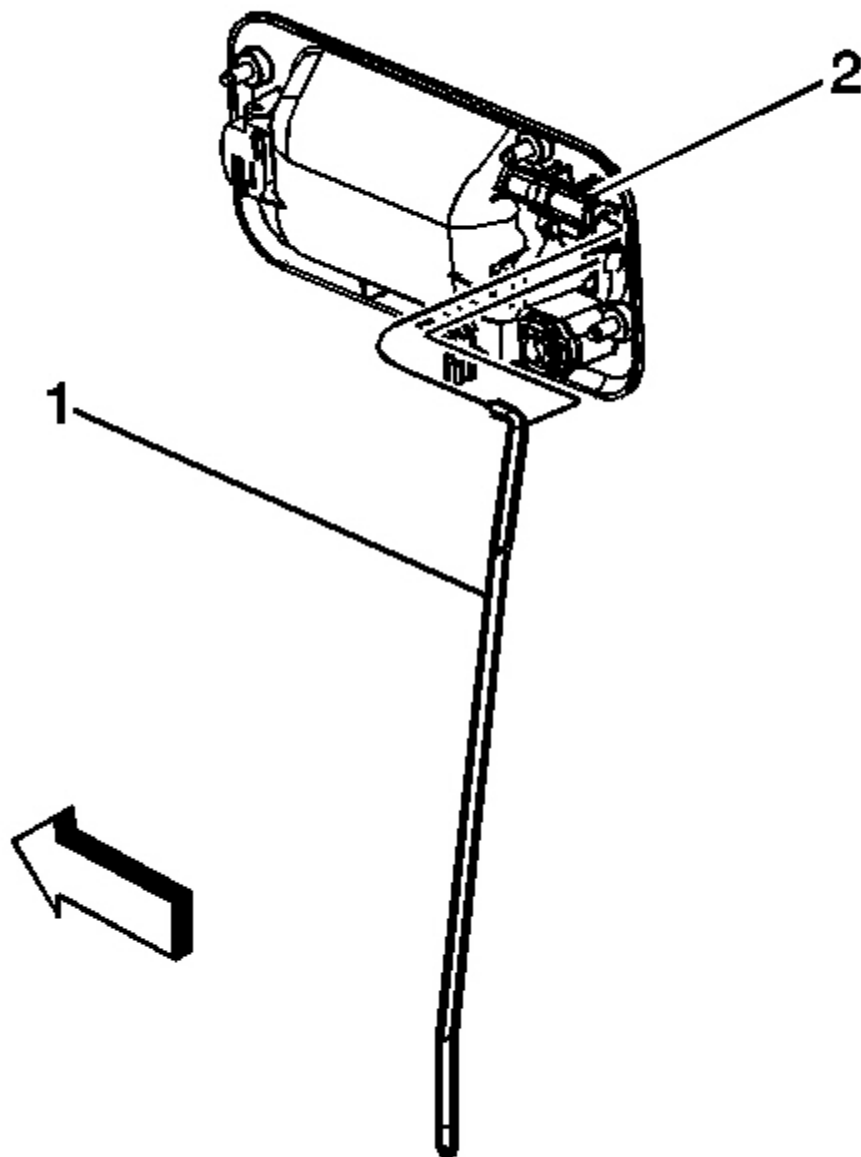

Fig. 63: Front Outside Door Handle Rod
Courtesy of GENERAL MOTORS CORP.

3. Connect the outside door handle rod (1) by securing the retention clip (2).

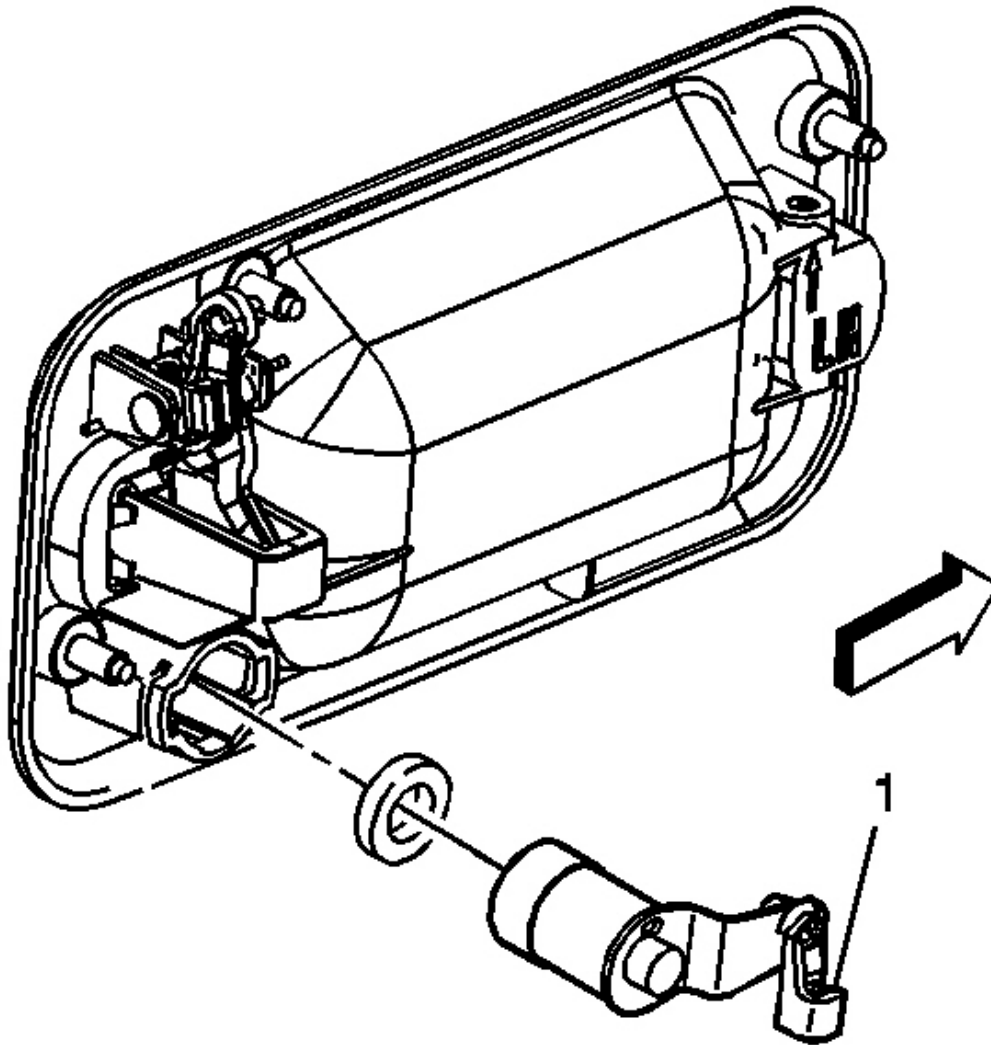

Fig. 64: Lock Cylinder Rod
Courtesy of GENERAL MOTORS CORP.

4. Connect the lock cylinder rod by securing the retainer clip (1).
5. Install the window. Refer to **Window Replacement - Front Door** .
6. Install the water deflector. Refer to **Water Deflector Replacement - Front Door** .
7. Install the door trim panel. Refer to **Trim Panel Replacement - Side Front Door** .

8. Operate the door handle to check for proper operation.

DOOR HANDLE REPLACEMENT - REAR OUTSIDE

Removal Procedure

1. Remove the door trim panel. Refer to **Trim Panel Replacement - Side Rear Door** .
2. Remove the water deflector. Refer to **Water Deflector Replacement - Rear Door** .
3. Apply a piece of masking tape across the door handle, on the outside of the door, to secure the door handle while removing the fasteners.

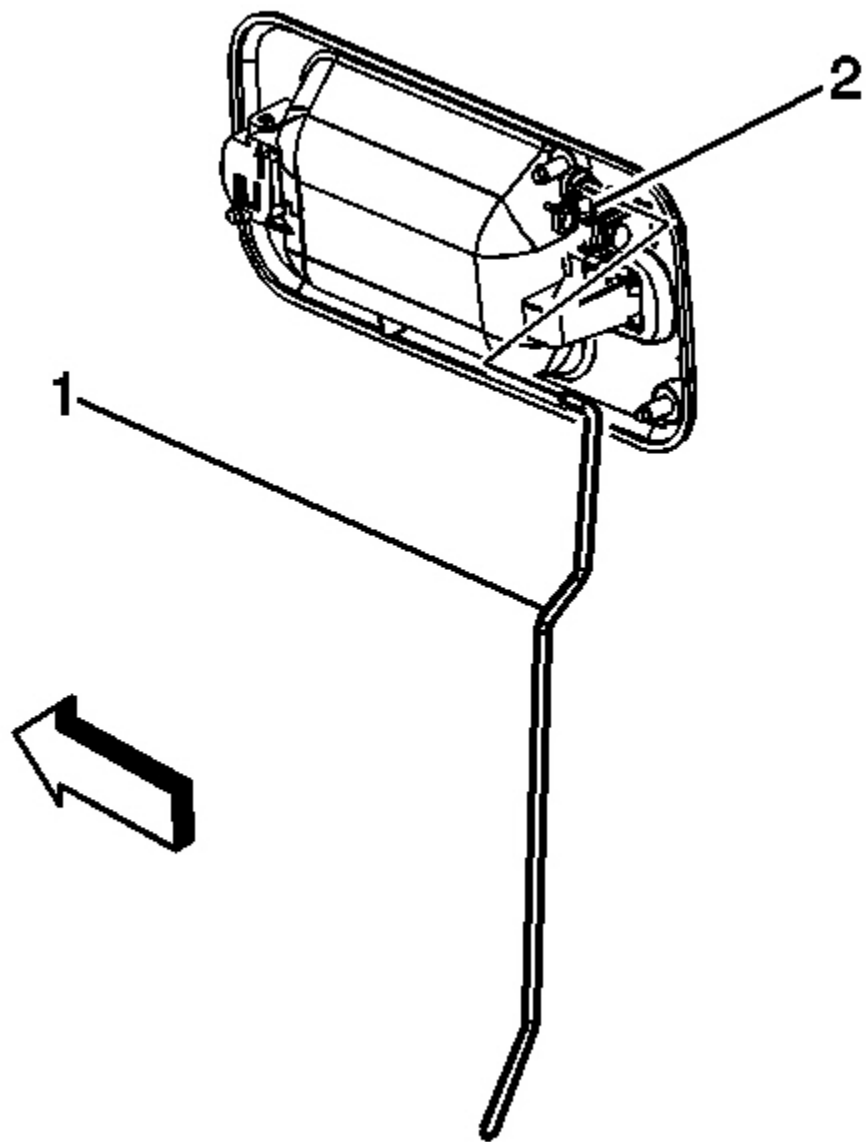

Fig. 65: Rear Outside Door Handle Rod
Courtesy of GENERAL MOTORS CORP.

4. Disconnect the outside door handle rod (1) by releasing the retaining clips (2).

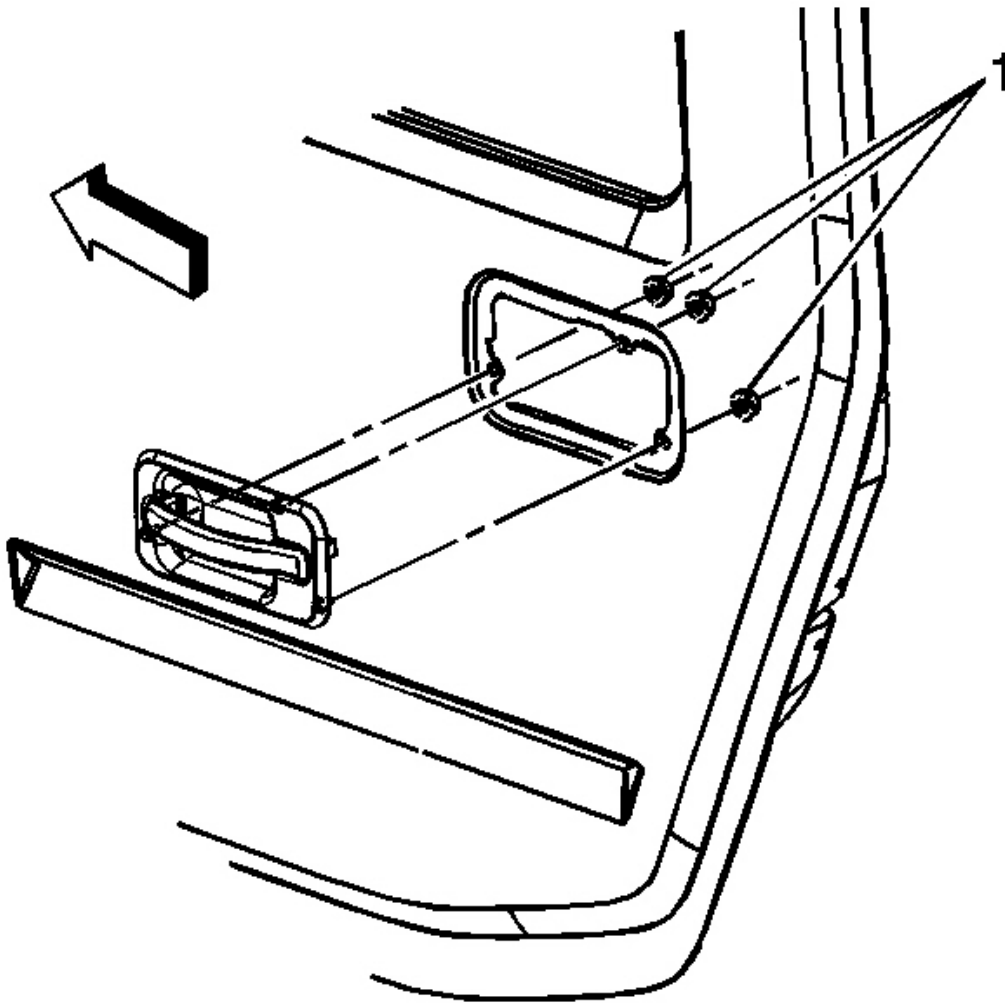

Fig. 66: Rear Outside Door Handle
Courtesy of GENERAL MOTORS CORP.

5. Remove the 3 nuts (1) retaining the door handle to the door.
6. Remove the door handle.

Installation Procedure

1. Position the door handle in place on the door.
2. Apply a piece of masking tape across the door handle on the outside of the door to secure the door handle while installing the fasteners.

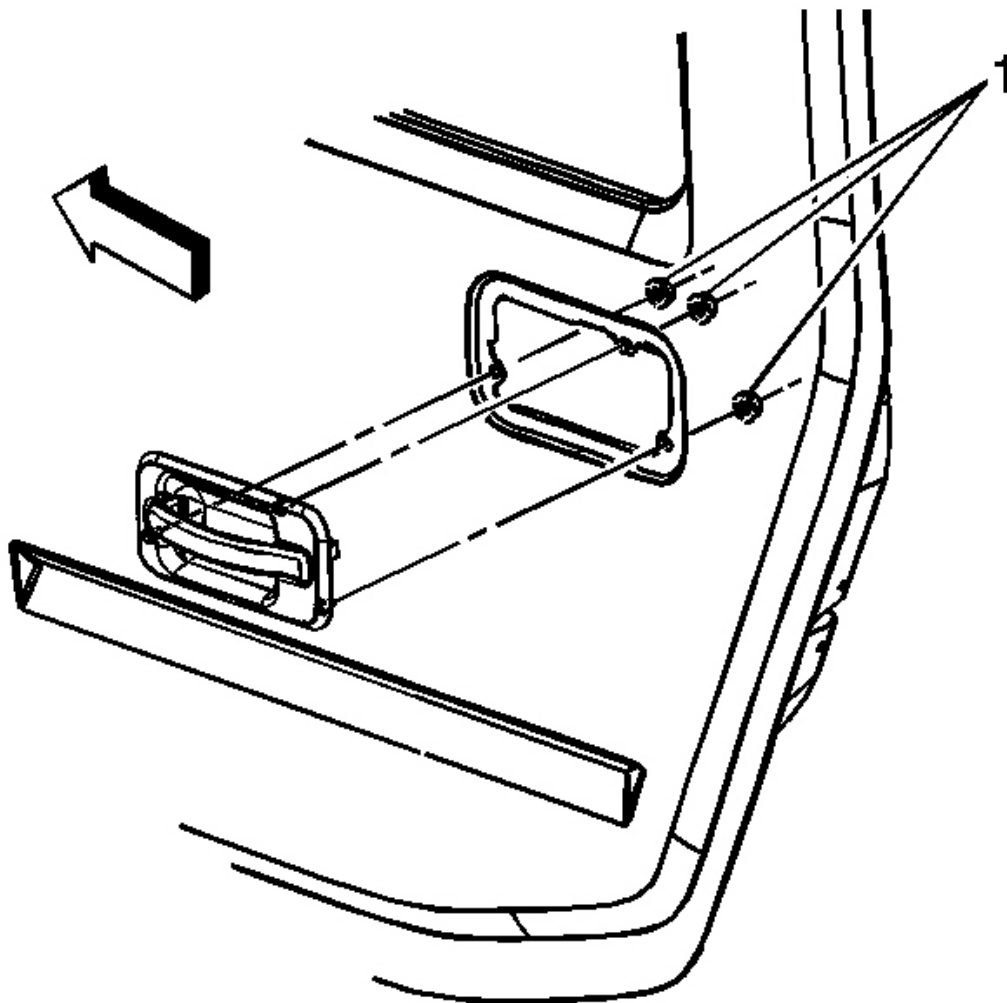

Fig. 67: Rear Outside Door Handle
Courtesy of GENERAL MOTORS CORP.

NOTE: Refer to Fastener Notice in Cautions and Notices.

3. Install the 3 nuts (1) that retain the door handle to the door.

Tighten: Tighten the nuts to 9 N.m (7 lb ft).

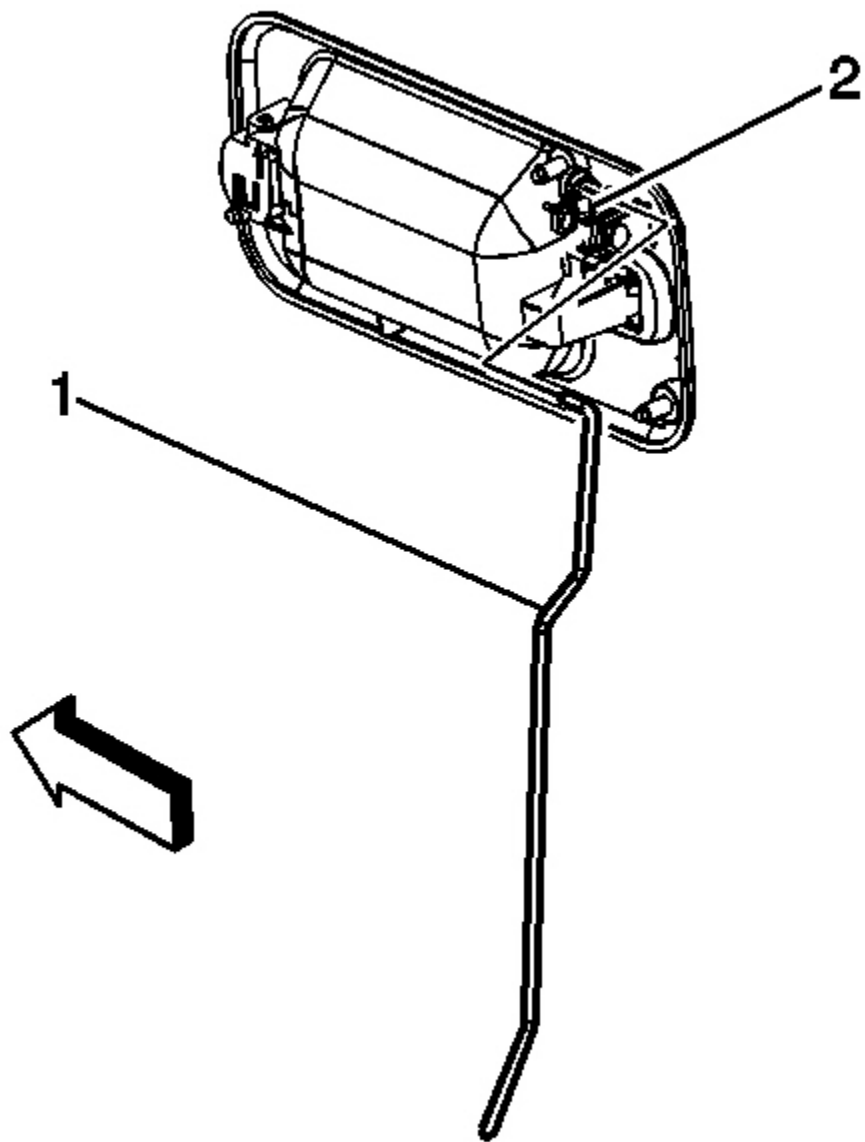

Fig. 68: Rear Outside Door Handle Rod
Courtesy of GENERAL MOTORS CORP.

4. Connect the outside door handle rod (1) by securing the retention clip (2).
5. Operate the door handle to ensure proper operation.
6. Install the water deflector. Refer to **Water Deflector Replacement - Rear Door** .

7. Install the door trim panel. Refer to **Trim Panel Replacement - Side Rear Door** .

DOOR HANDLE REPLACEMENT - FRONT INSIDE

Removal Procedure

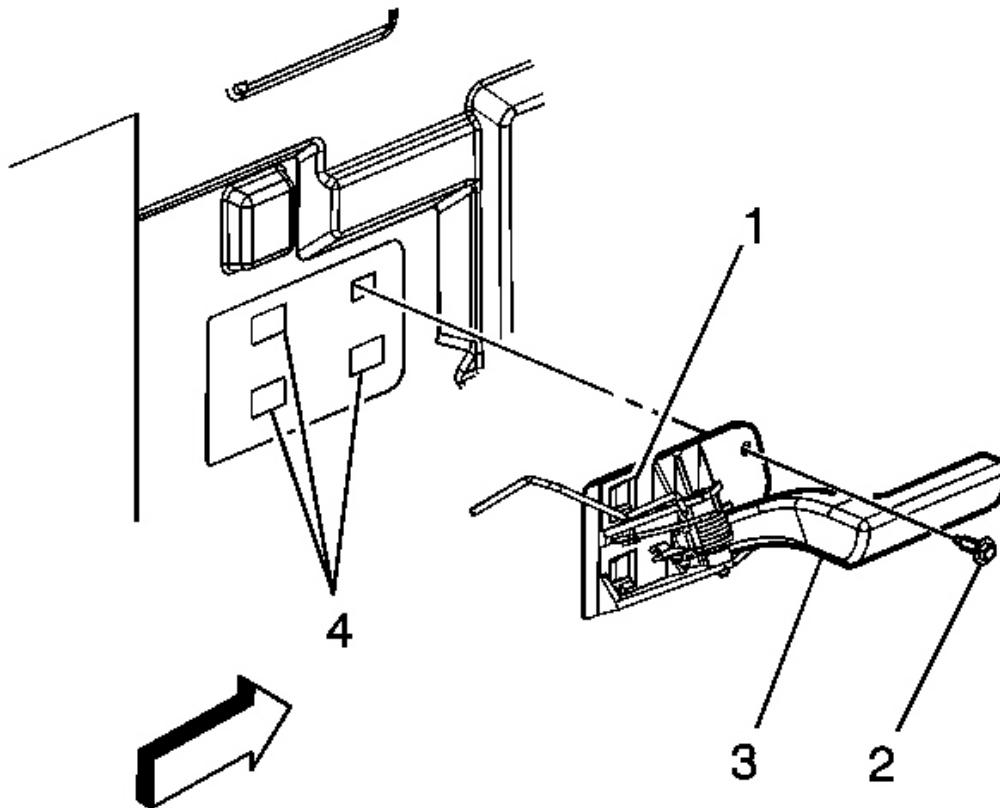

Fig. 69: Front Inside Door Handle
Courtesy of GENERAL MOTORS CORP.

1. Open the door.
2. Remove door trim panel. Refer to **Trim Panel Replacement - Side Front Door** .
3. Release the inside door handle rod retention clip (1).
4. Remove the fastener (2) retaining the door handle (3) to the door.
5. Remove the door handle by sliding the handle out of the retaining slots (4).

Installation Procedure

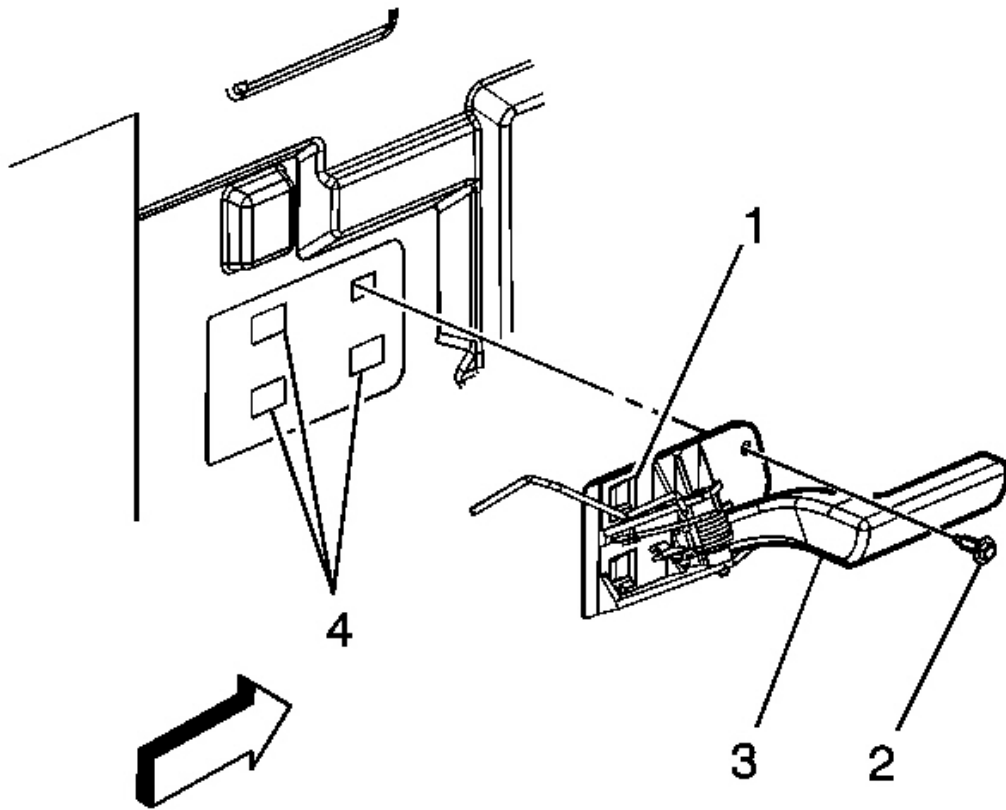

Fig. 70: Front Inside Door Handle
Courtesy of GENERAL MOTORS CORP.

1. Position the door handle in the retention slots.

NOTE: Refer to Fastener Notice in Cautions and Notices.

2. Install the fastener (2) retaining the door handle to the door.

Tighten: Tighten the fastener to 9 N.m (7 lb ft).

3. Attach the inside door handle rod retention clip (1).
4. Install the door trim panel. Refer to Trim Panel Replacement - Side Front Door .
5. Close the door.

Removal Procedure

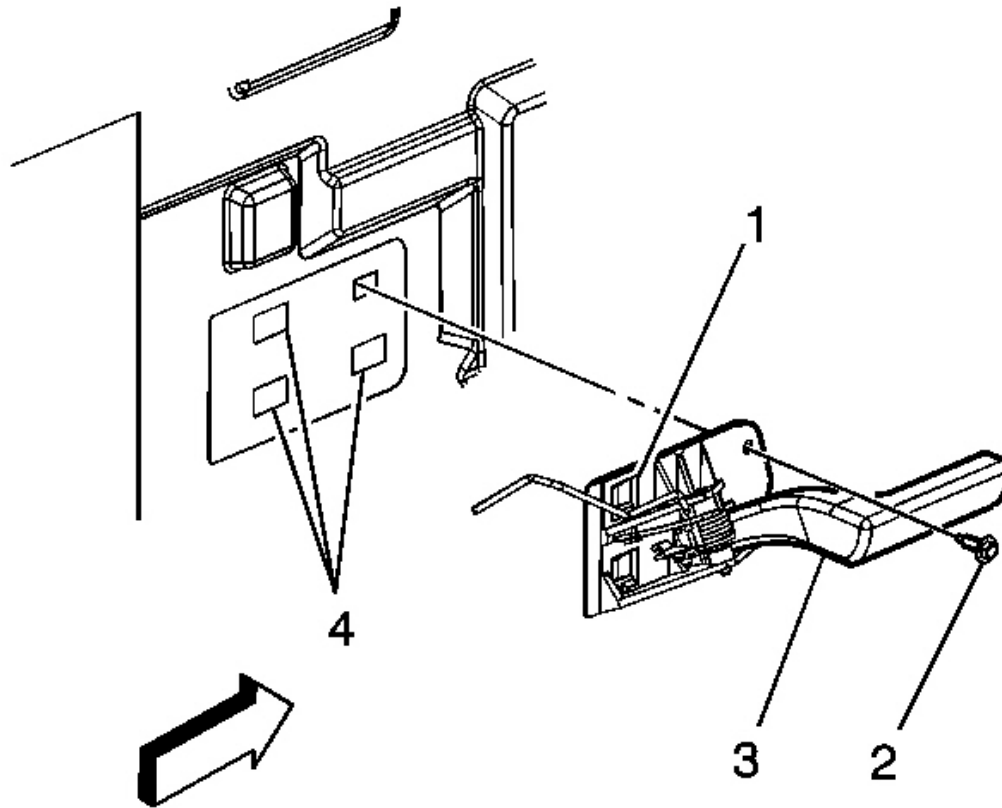

Fig. 71: Rear Inside Door Handle
Courtesy of GENERAL MOTORS CORP.

1. Open the door.
2. Remove door trim panel. Refer to **Trim Panel Replacement - Side Front Door** .
3. Release the inside door handle rod retention clip (1).
4. Remove the fastener (2) retaining the door handle (3) to the door.
5. Remove the door handle by sliding the handle out of the retention slots (4).

Installation Procedure

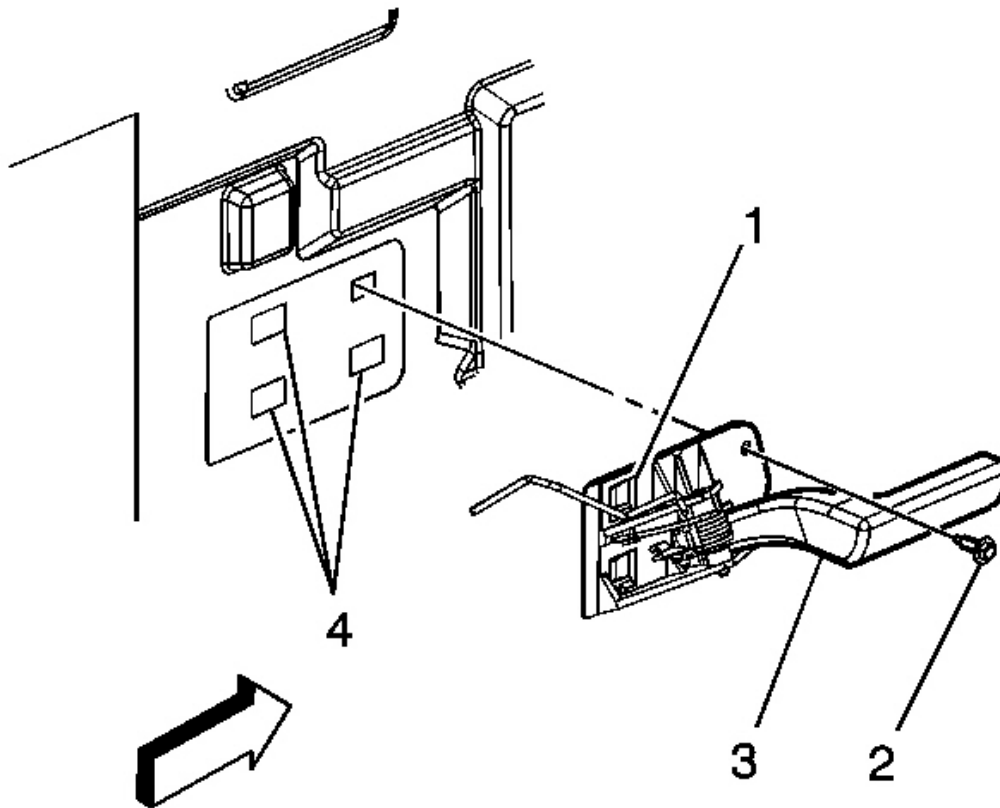

Fig. 72: Rear Inside Door Handle
Courtesy of GENERAL MOTORS CORP.

1. Position the door handle in the retention slots (4).

NOTE: Refer to Fastener Notice in Cautions and Notices.

2. Install the fastener (2) retaining the door handle to the door.

Tighten: Tighten the fasteners to 9 N.m (7 lb ft).

3. Attach the inside door handle rod retention clip (1).
4. Install the door trim panel. Refer to Trim Panel Replacement - Side Front Door.
5. Close the door.

Removal Procedure

1. Remove the outside door handle. Refer to Door Handle Replacement - Front Outside .

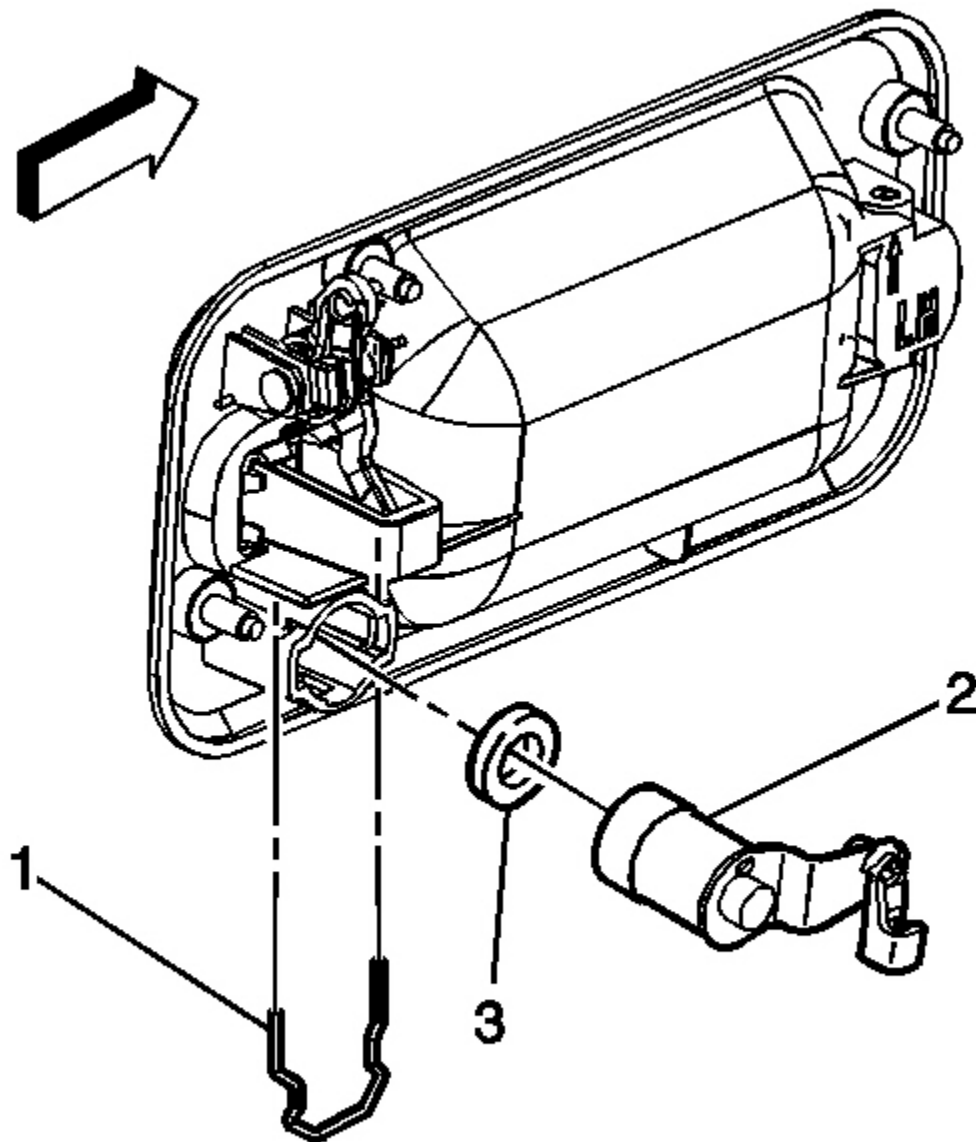

Fig. 73: Door Lock Cylinder
Courtesy of GENERAL MOTORS CORP.

2. Remove the lock cylinder retainer (1).
3. Remove the lock cylinder (2).

Installation Procedure

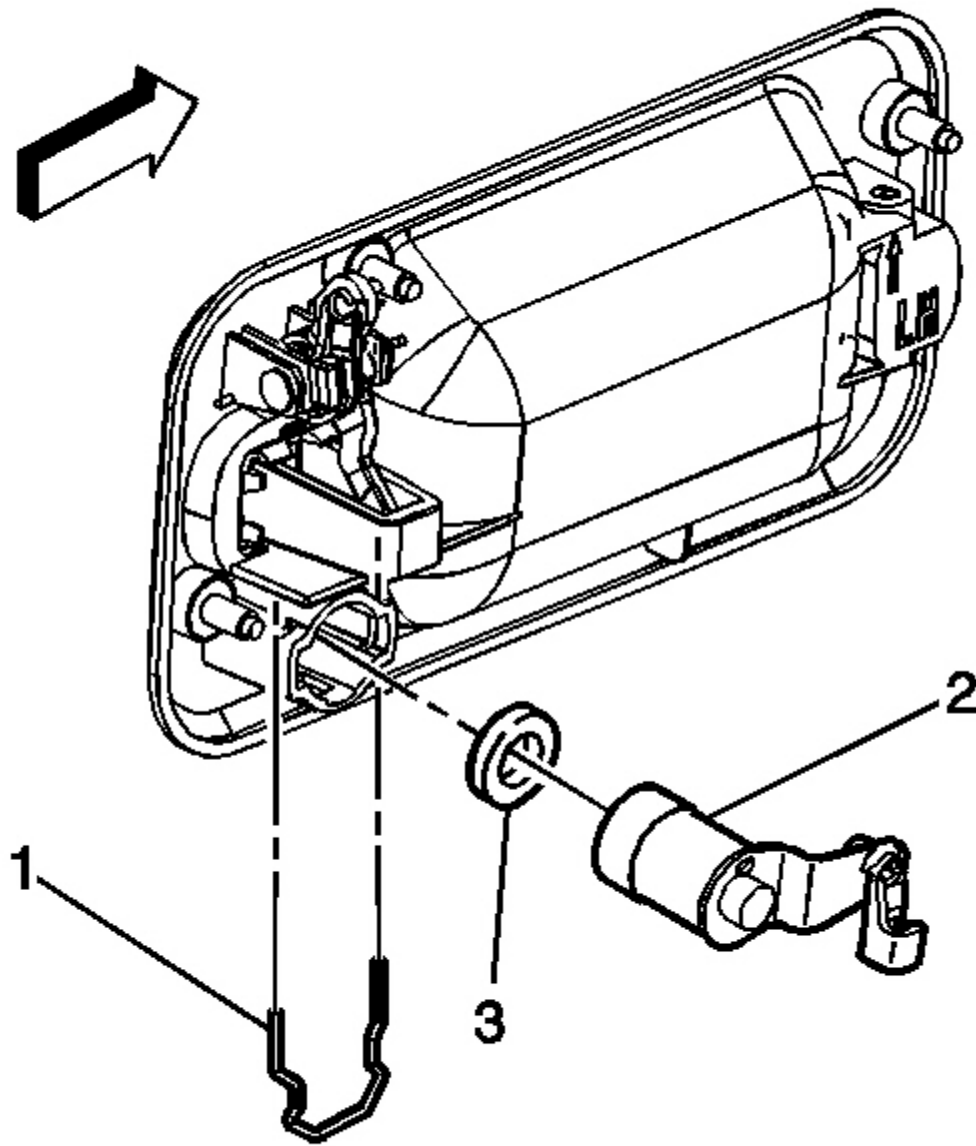

Fig. 74: Door Lock Cylinder

Courtesy of GENERAL MOTORS CORP.

1. Ensure that the lock cylinder gasket (3) is in place before lock cylinder installation.
2. Install the lock cylinder (2) into the door handle.
3. Install the lock cylinder retainer (2), ensuring that the retainer is fully seated.
4. Install the outside door handle. Refer to **Door Handle Replacement - Front Outside** .

BINDING LOCK CYLINDERS

In many cases, applying the proper lubrication can correct the following conditions:

- Binding or sticking door lock cylinders
- Difficulty in inserting and removing the keys

For lubricating the above components, use lubricant GM P/N 12346241 or equivalent

Do not use penetrating lubricants such as GM P/N 1052949 or WD-40(R). Penetrating lubricants wash out the original lubrication. Penetrating lubricants eventually evaporate, leaving little or no lubricating material. However, when using penetrating lubricants in order to thaw or in order to loosen the lock cylinder components, refer to steps 2-4 in the procedure below for the proper methods of lubrication.

Repair lock cylinders frozen in cold weather by using the following procedure:

1. While carefully avoiding damage to the painted surfaces, apply heat to the cylinder with a heat gun.
2. Using a paper clip or a similar item, hold the door shutter open.

Force air into the cylinders using compressed air through a blow gun attachment.

3. While holding the shutter door open, inject small amounts of a recommended lubricant into the cylinder.
4. Work the key into the cylinder repeatedly.

Wipe away any excess lubrication from the key.

LATCH REPLACEMENT - FRONT DOOR

Removal Procedure

1. Open the door.
2. Remove the door trim panel. Refer to **Trim Panel Replacement - Side Front Door** .
3. Remove the water deflector. Refer to **Water Deflector Replacement - Front Door** .
4. Remove the window run channel. Refer to **Window Run Channel Replacement - Front Door** .
5. Disconnect the lock actuator electrical connector.

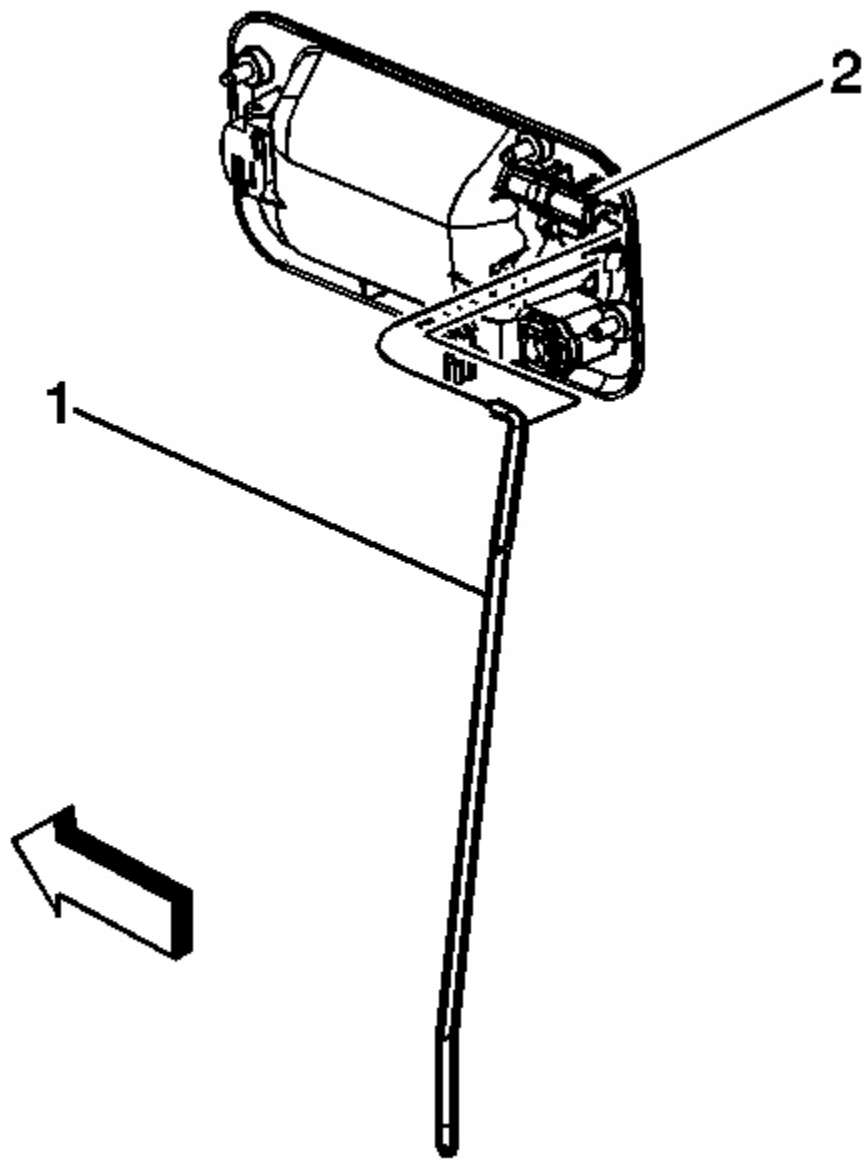

Fig. 75: Front Outside Door Handle Rod
Courtesy of GENERAL MOTORS CORP.

6. Disconnect the outside door handle rod (1) by releasing the retaining clip on the door latch.

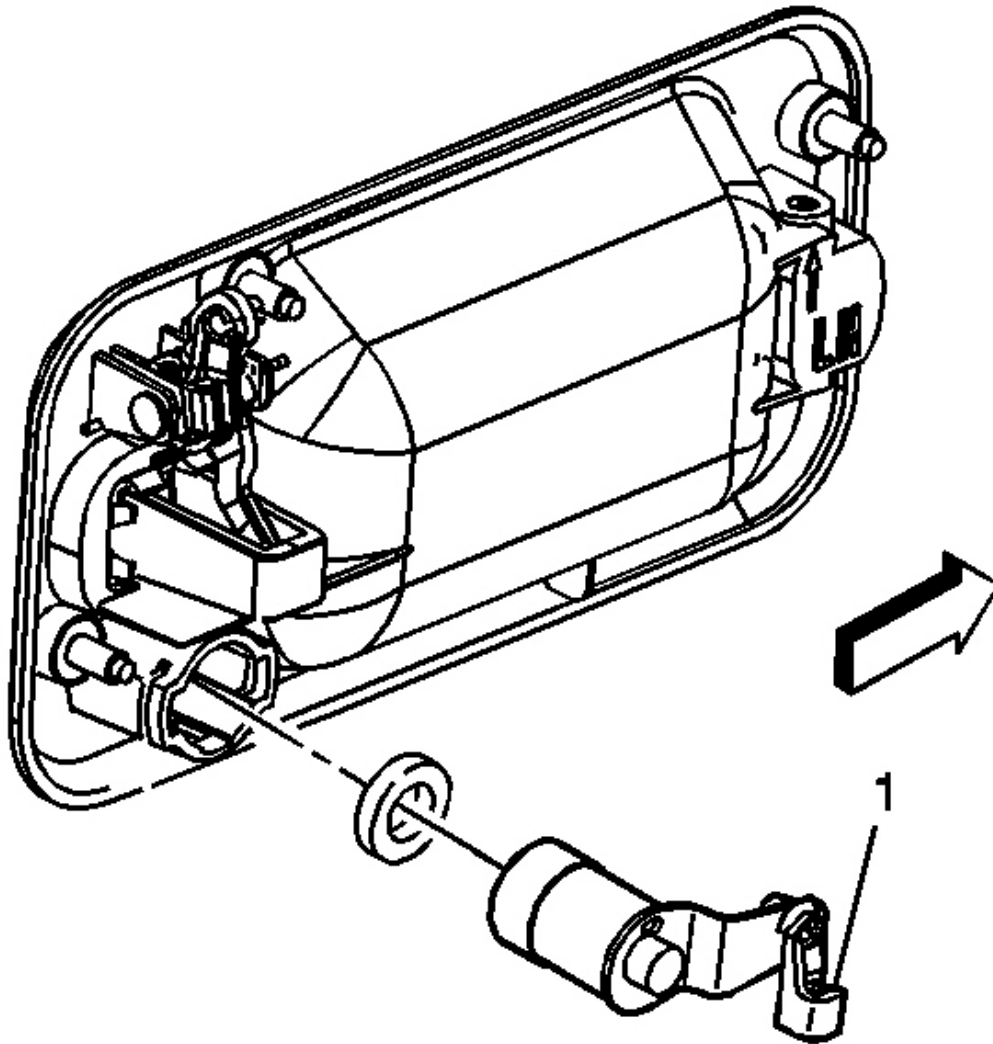

Fig. 76: Lock Cylinder Rod
Courtesy of GENERAL MOTORS CORP.

7. Disconnect the lock cylinder rod by releasing the retaining clip (1).
8. Remove the manual locking rod from the door by releasing the rod from the retainers.

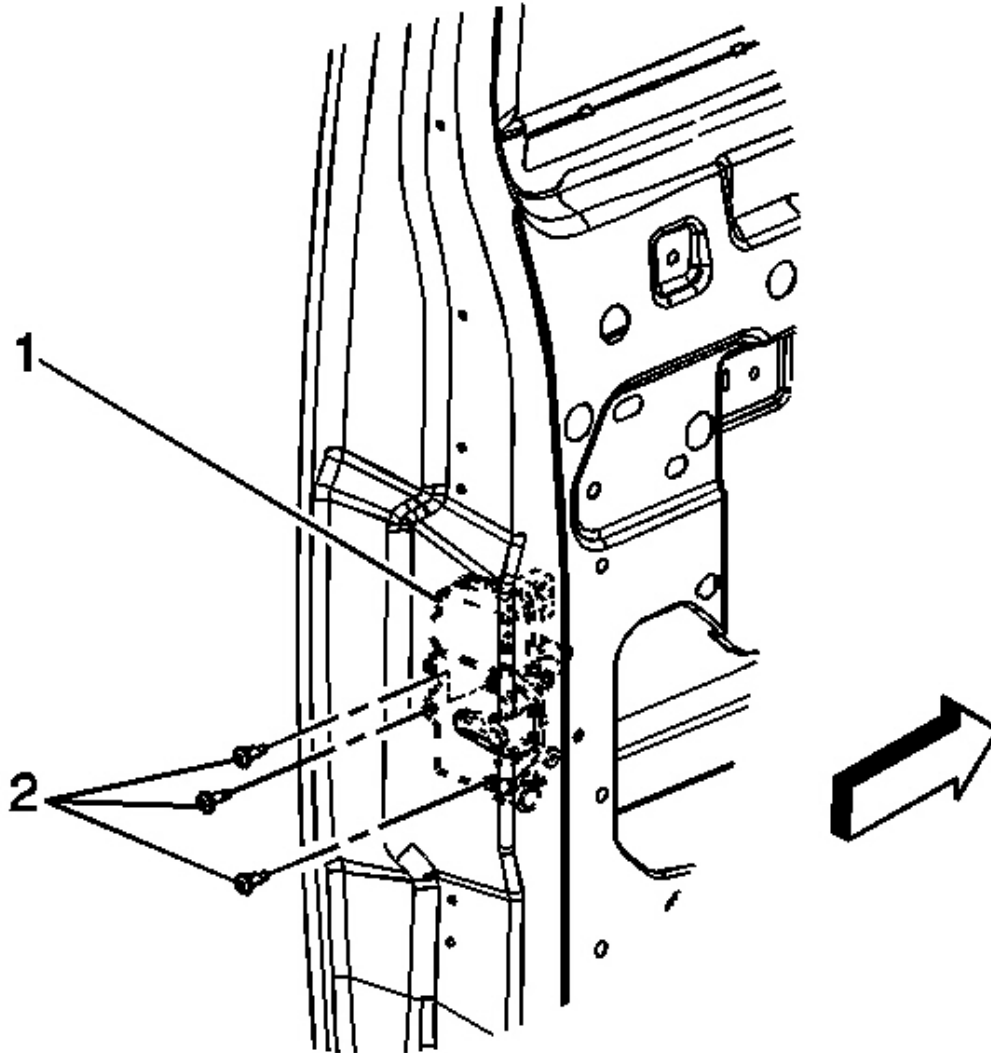

Fig. 77: Front Door Latch
Courtesy of GENERAL MOTORS CORP.

9. Remove the fasteners (2) retaining the door latch (1) to the door.
10. Remove the door latch (1).

Installation Procedure

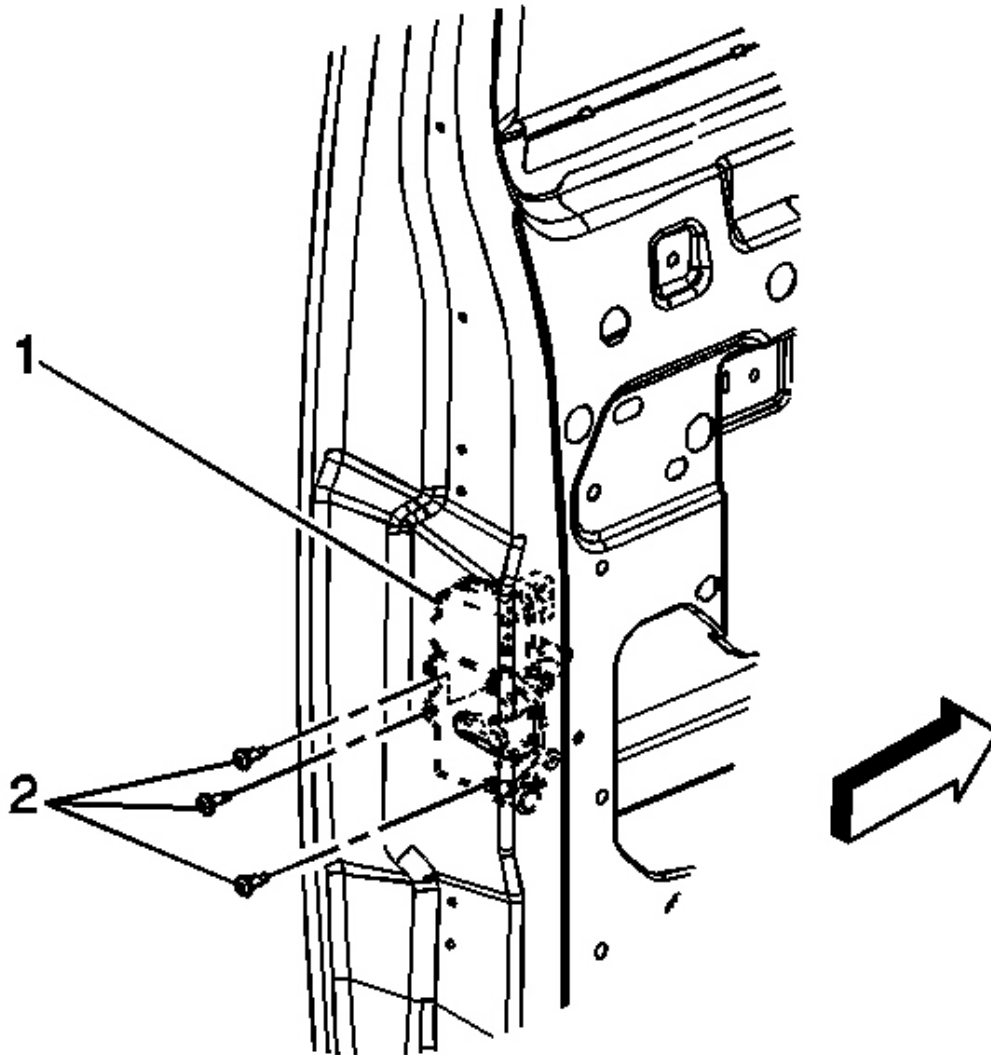

Fig. 78: Front Door Latch
Courtesy of GENERAL MOTORS CORP.

NOTE: Refer to Fastener Notice in Cautions and Notices.

1. Place the latch (1) into position in the door, and install the 3 fasteners (2) that retain the latch to the door.

Tighten: Tighten the fasteners to 9 N.m (7 lb ft).

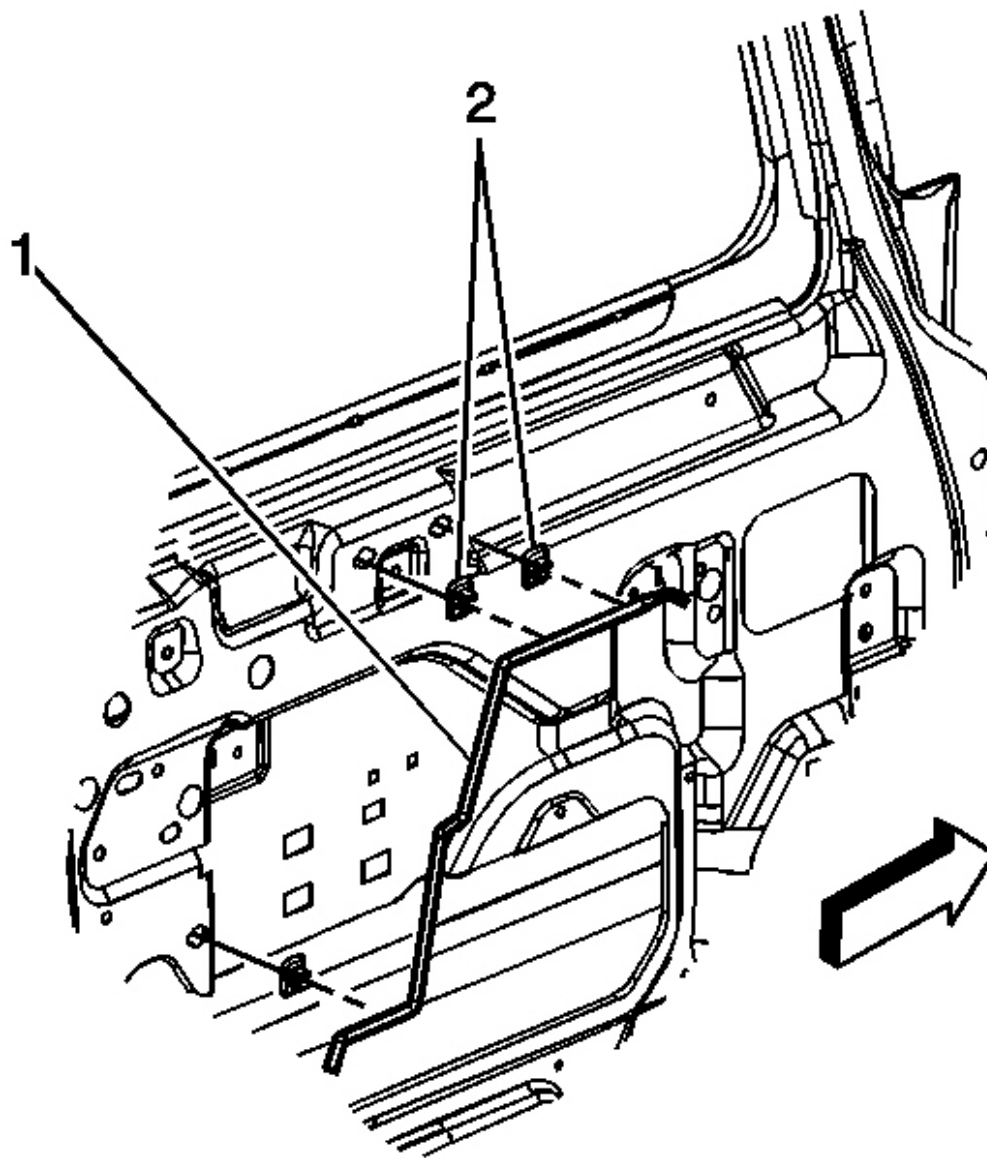

Fig. 79: Manual Locking Rod
Courtesy of GENERAL MOTORS CORP.

2. Install the manual locking rod (1) to the door by securing the rod in the retainers.

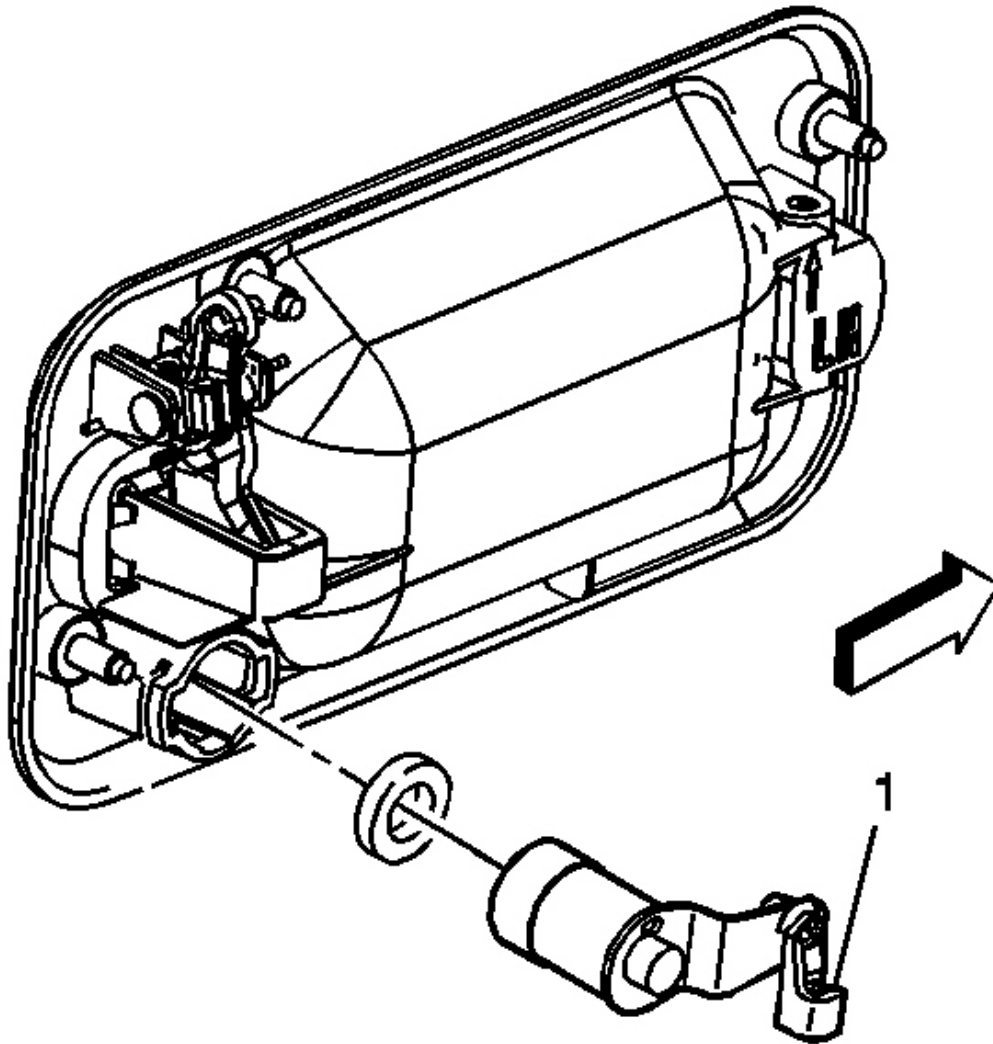

Fig. 80: Lock Cylinder Rod
Courtesy of GENERAL MOTORS CORP.

3. Connect the lock cylinder rod by securing rod in the retaining clip (1).

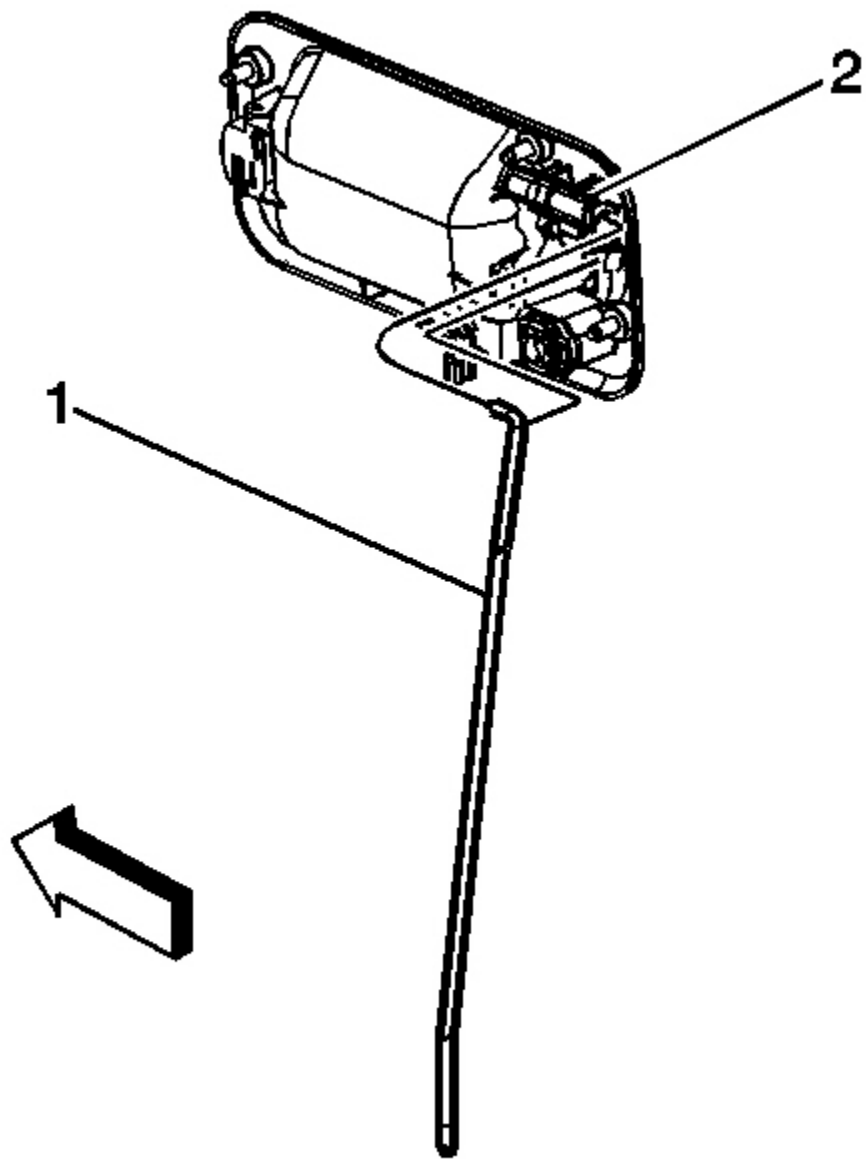

Fig. 81: Front Outside Door Handle Rod
Courtesy of GENERAL MOTORS CORP.

4. Connect the outside door handle rod (1) by securing the rod in the retaining clip on the door latch.
5. Connect the lock actuator electrical connector.
6. Operate door handle functions to ensure proper operation.

7. Install the window run channel. Refer to **Window Run Channel Replacement - Front Door** .
8. Install water deflector. Refer to **Water Deflector Replacement - Front Door** .
9. Install door trim panel. Refer to **Trim Panel Replacement - Side Front Door** .

LATCH REPLACEMENT - REAR DOOR

Removal Procedure

1. Open the door.
2. Remove the door trim panel. Refer to **Trim Panel Replacement - Side Rear Door** .
3. Remove the water deflector. Refer to **Water Deflector Replacement - Rear Door** .
4. Disconnect the lock actuator electrical connector.

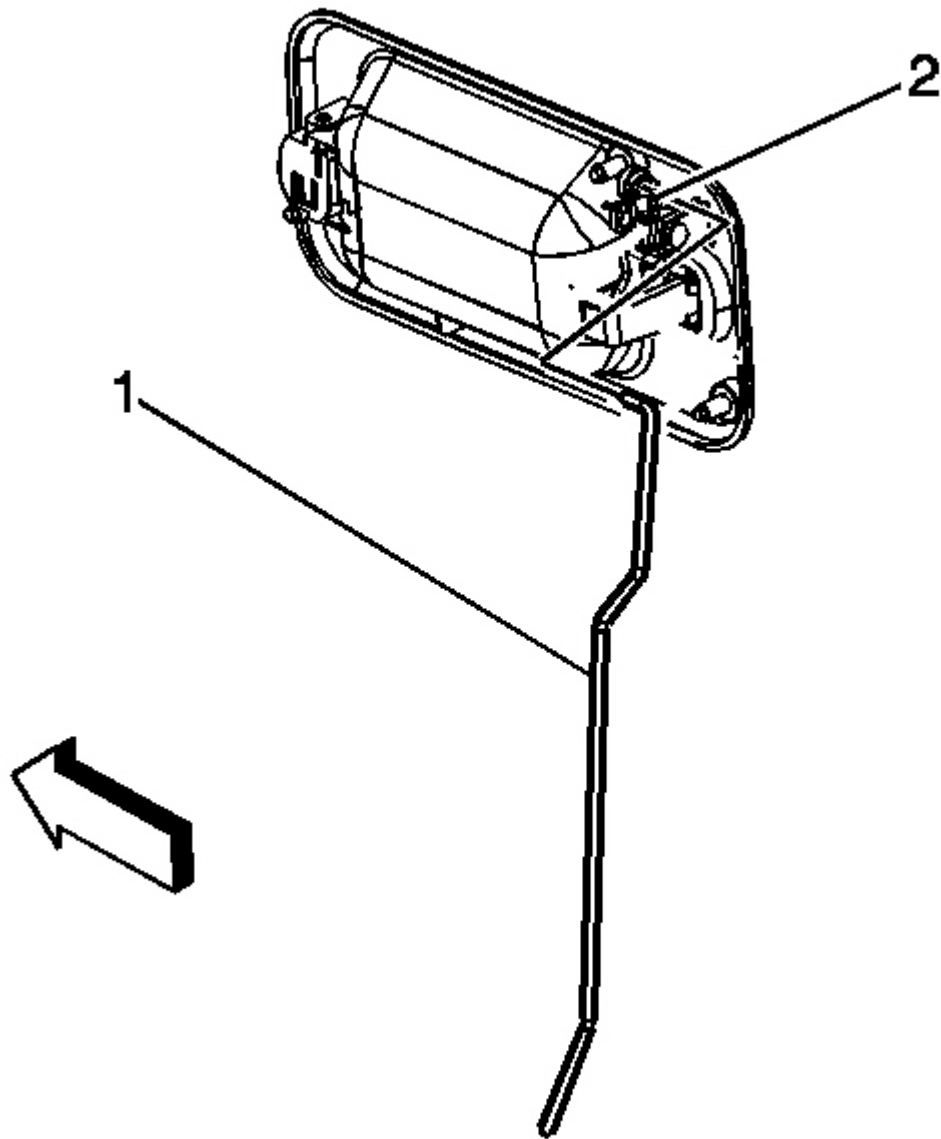

Fig. 82: Rear Outside Door Handle Rod
Courtesy of GENERAL MOTORS CORP.

5. Disconnect the outside door handle rod (1) by releasing the retaining clip on the door latch.

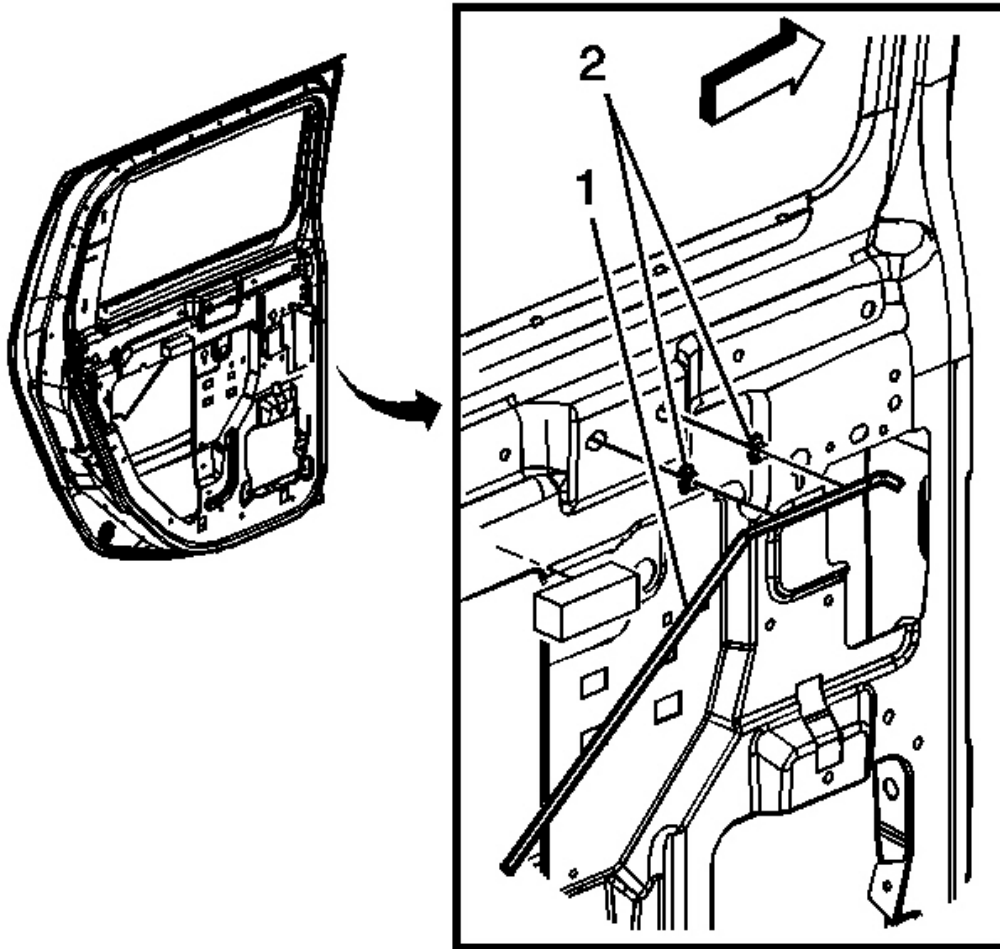

Fig. 83: Manual Locking Rod
Courtesy of GENERAL MOTORS CORP.

6. Remove the manual locking rod (1) from the door by releasing the rod from the retainers (2).

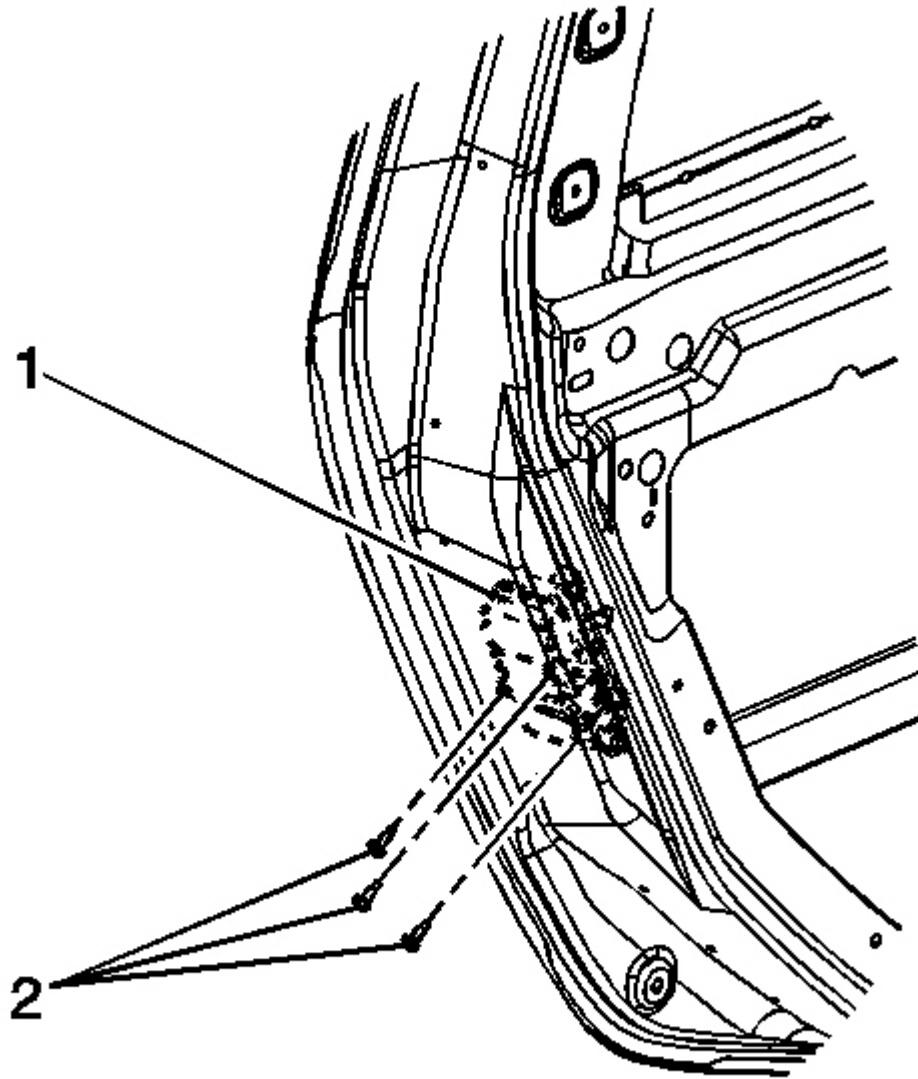

Fig. 84: Rear Door Latch
Courtesy of GENERAL MOTORS CORP.

7. Remove the fasteners (2) retaining the door latch (1) to the door.
8. Remove the door latch.

Installation Procedure

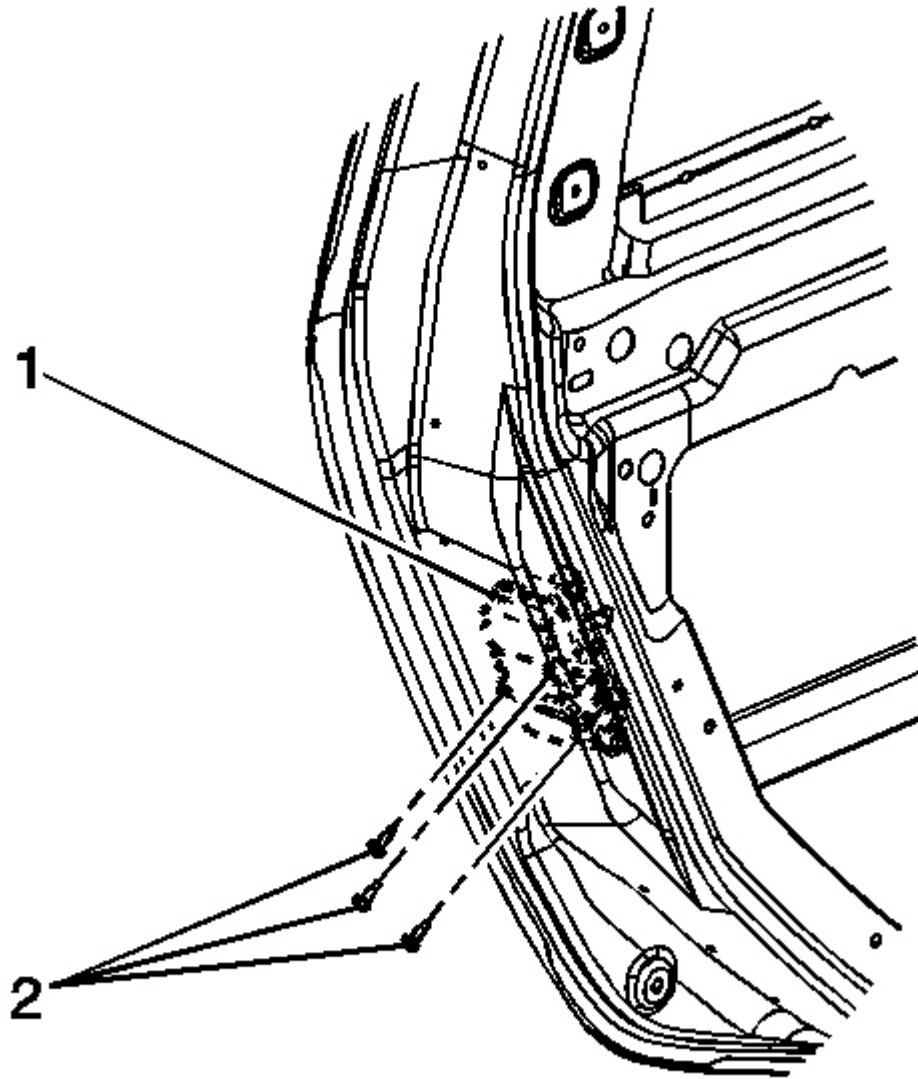

Fig. 85: Rear Door Latch
Courtesy of GENERAL MOTORS CORP.

NOTE: Refer to Fastener Notice in Cautions and Notices.

1. Place the latch (1) into position in the door, and install the 3 fasteners (2) that retain the latch to the door.

Tighten: Tighten the fasteners to 9 N.m (7 lb ft).

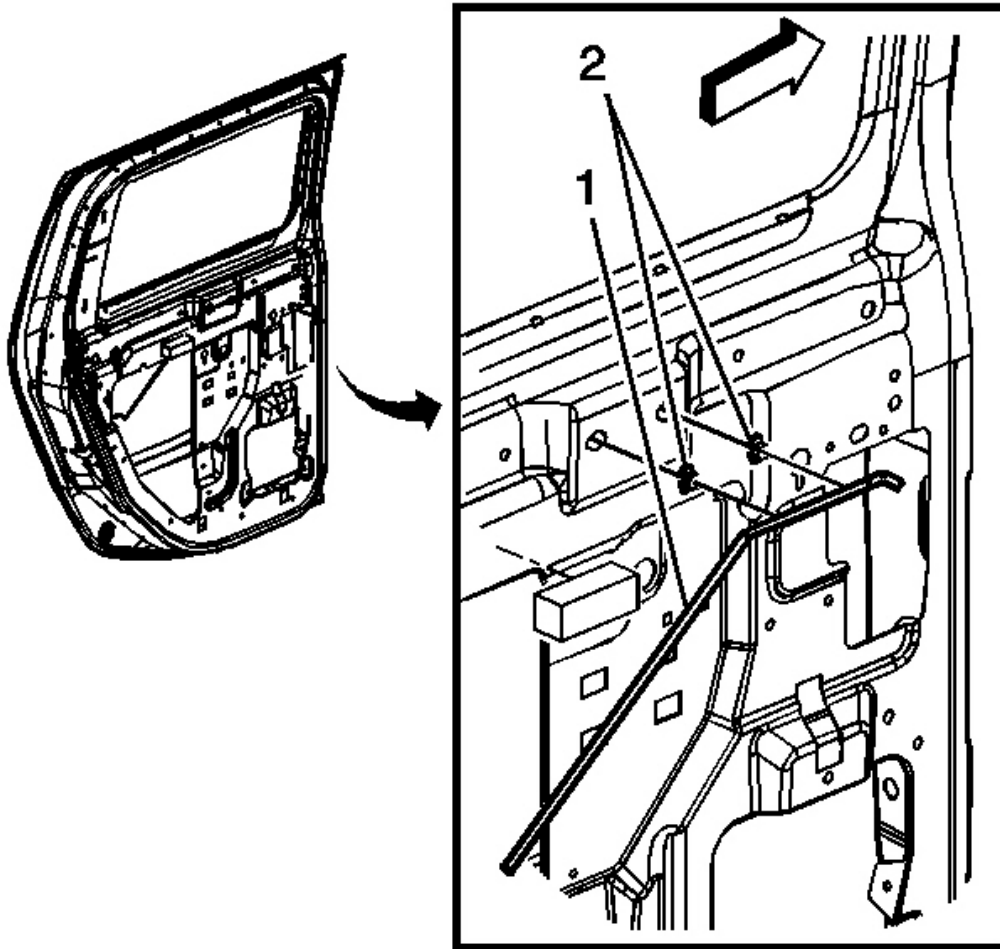

Fig. 86: Manual Locking Rod
Courtesy of GENERAL MOTORS CORP.

2. Install the manual locking rod (1) to the door by securing the rod in the retainers (2).

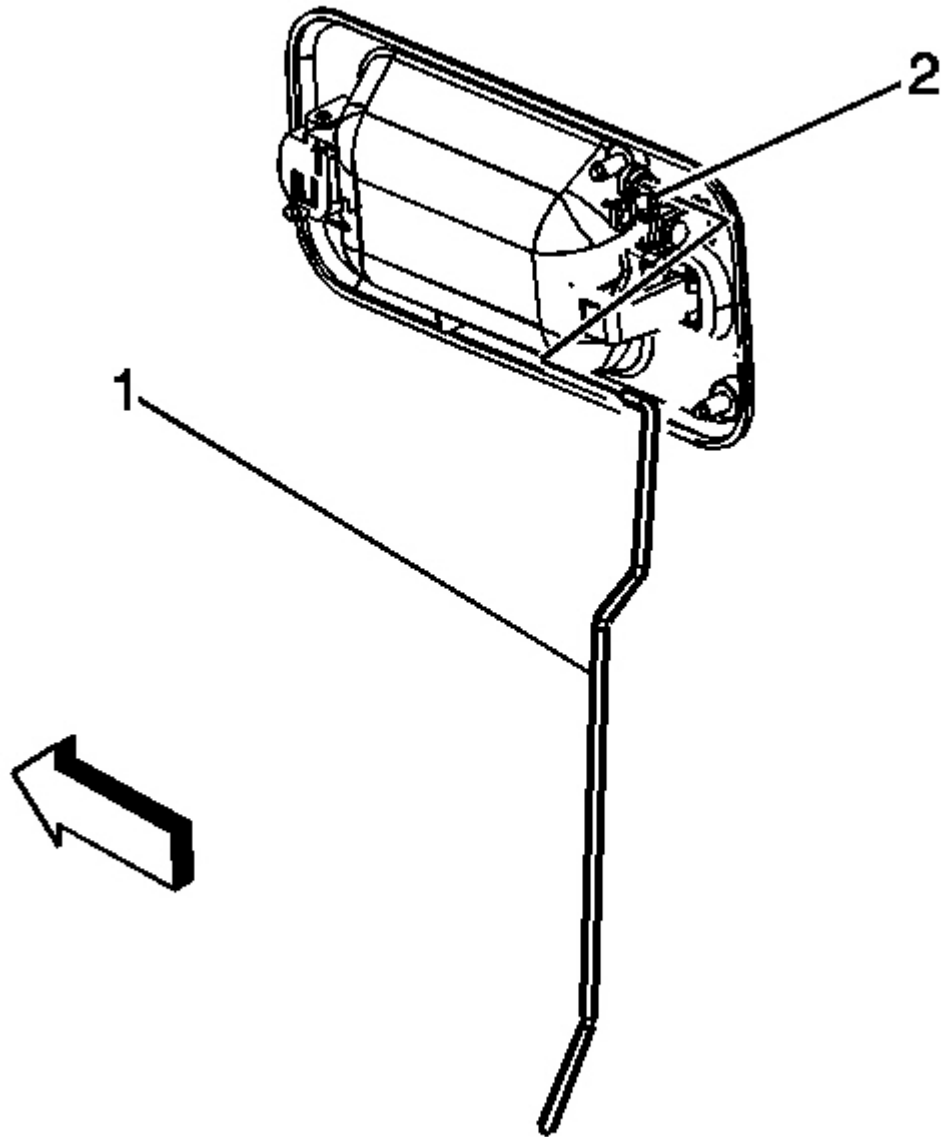

Fig. 87: Rear Outside Door Handle Rod
Courtesy of GENERAL MOTORS CORP.

3. Connect the outside door handle rod (1) by securing the rod in the retaining clip on the door latch.
4. Connect the lock actuator electrical connector.
5. Operate the door handle functions to ensure proper operation.

6. Install the window run channel. Refer to **Window Run Channel Replacement - Rear Door** .
7. Install the water deflector. Refer to **Water Deflector Replacement - Rear Door** .
8. Install the door trim panel. Refer to **Trim Panel Replacement - Side Rear Door** .

STRIKER REPLACEMENT - DOOR

Removal Procedure

1. Mark the striker position with a grease pencil prior to removal, to retain proper alignment.
2. Open the door.

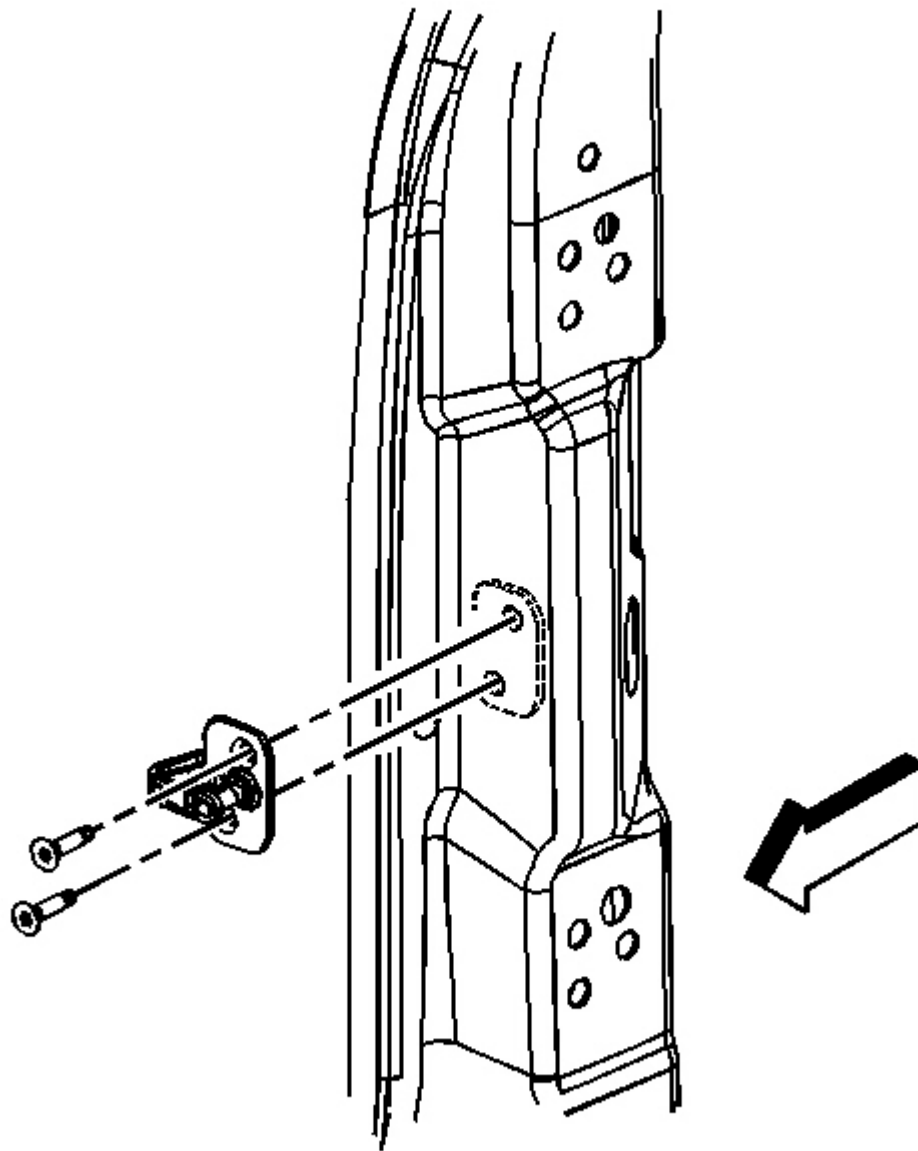

Fig. 88: Door Lock Striker
Courtesy of GENERAL MOTORS CORP.

3. Remove the fasteners retaining the striker to the door frame.
4. Remove the striker.

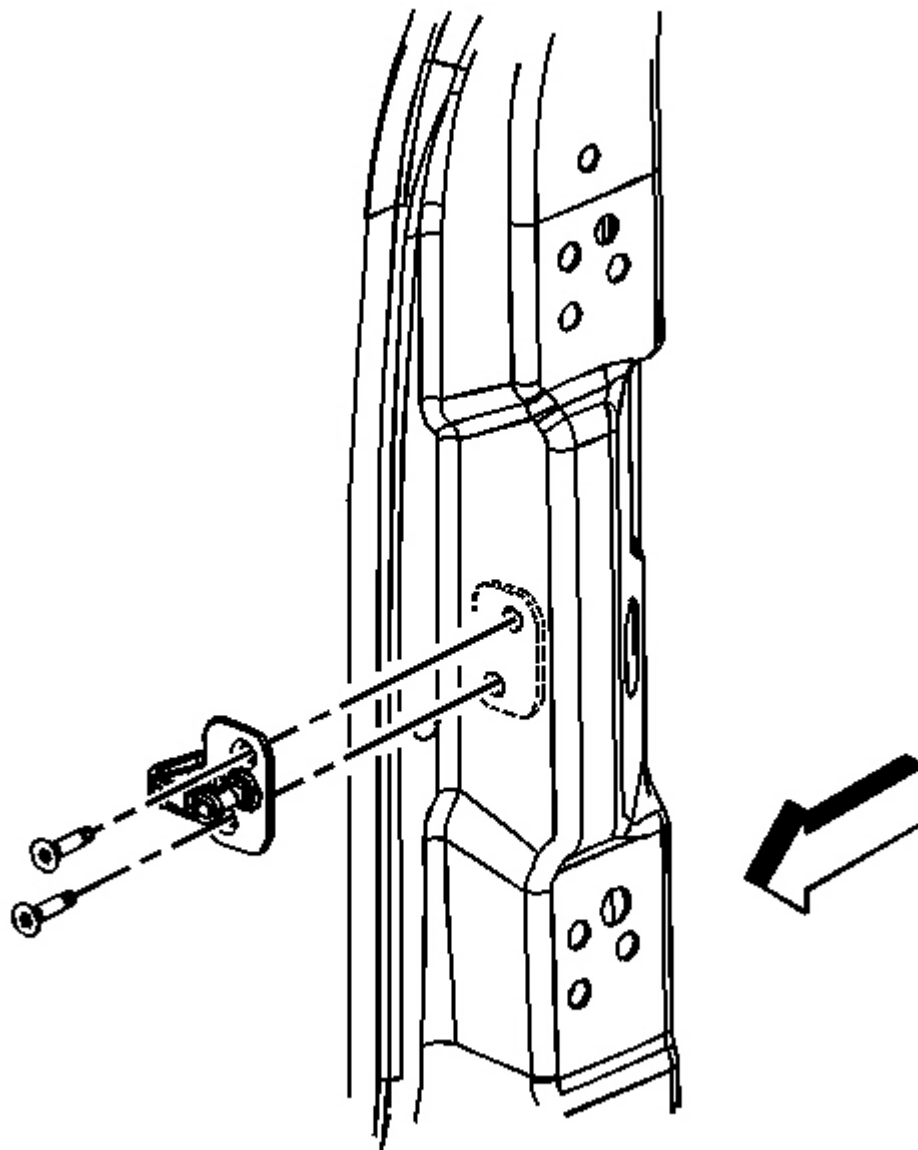

Fig. 89: Door Lock Striker
Courtesy of GENERAL MOTORS CORP.

1. Align the striker with the alignment marks made with the grease pencil.

NOTE: Refer to Fastener Notice in Cautions and Notices.

2. Install the fasteners retaining the striker to the door frame.

Tighten: Tighten the fasteners to 27 N.m (20 lb ft).

3. Operate the door to check for proper operation and alignment.

LOCK STRIKER ADJUSTMENT - DOOR

To determine if striker adjustment is required, proceed as follows:

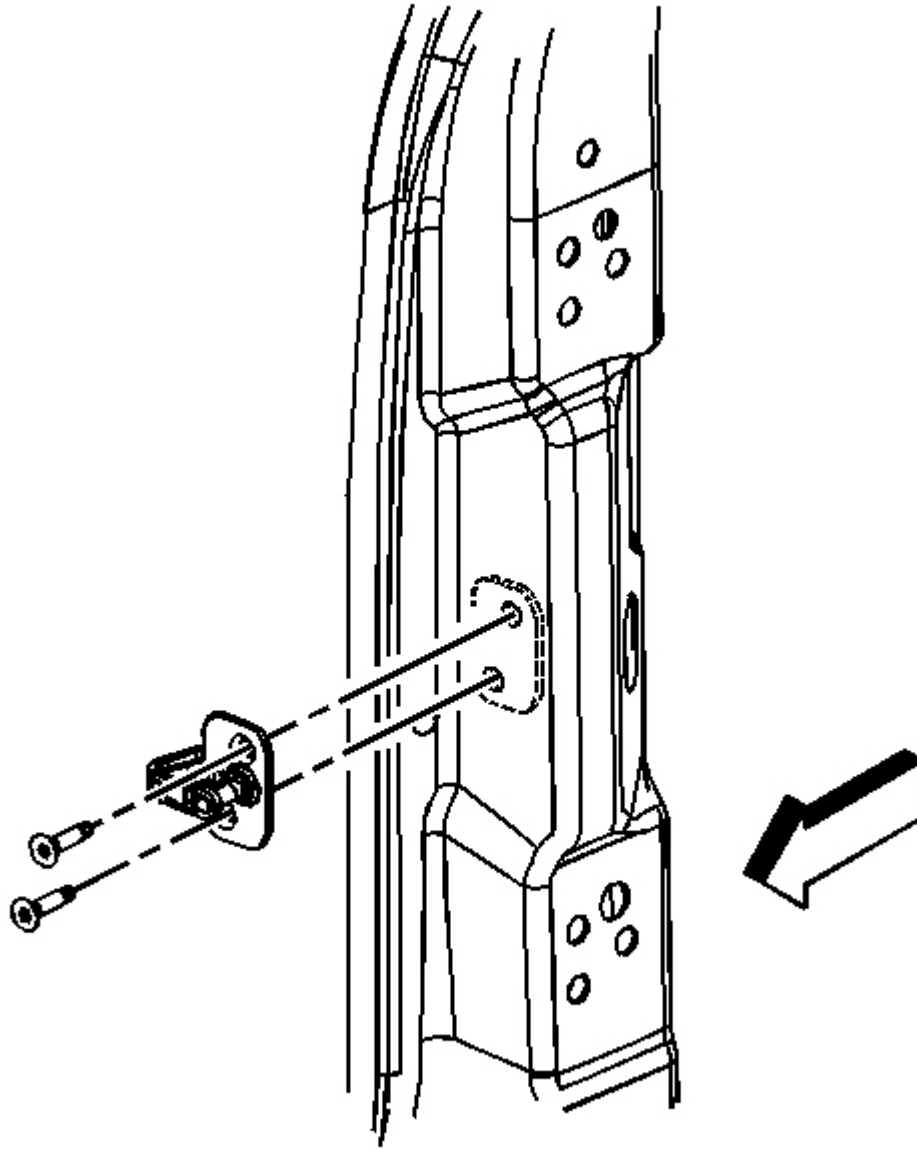

Fig. 90: Door Lock Striker
Courtesy of GENERAL MOTORS CORP.

1. Make certain the door is properly aligned within the door opening before proceeding with the striker adjustment.
2. Close the door onto the striker and note if the door drags on the striker causing the door to move upward

or downward upon contact with the striker. Also note the closing effort to fully engage the latch.

3. Using a soft marker, mark around the striker for reference of the original position. Loosen the striker.
4. Move the striker to eliminate drag on the striker and door latch and to achieve the proper door position within the door opening. Start with the up/down position, then position the striker to achieve proper alignment to the door opening. Set the in/out adjustment for the proper door seal engagement making sure the door closing efforts are correct.

NOTE: Refer to Fastener Notice in **Cautions and Notices**.

5. Tighten the striker-to-body bolts.

Tighten: Tighten the door striker-to-body bolts to 27 N.m (20 lb ft).

DOOR HARDWARE LUBRICATION

The mechanical components of the door assembly receive lubrication during the assembly. If any door hardware mechanism needs additional lubrication, use multi-purpose lubricant GM P/N 12346241 or Canadian P/N 10953474 or equivalent.

WIRING HARNESS REPLACEMENT - FRONT DOOR

Removal Procedure

1. Remove the door trim panel. Refer to Trim Panel Replacement - Side Front Door .
2. Remove water deflector. Refer to Water Deflector Replacement - Front Door .
3. Disconnect the speaker electrical connector.
4. Disconnect the door lock actuator electrical connector.
5. Disconnect the power mirror electrical connector.

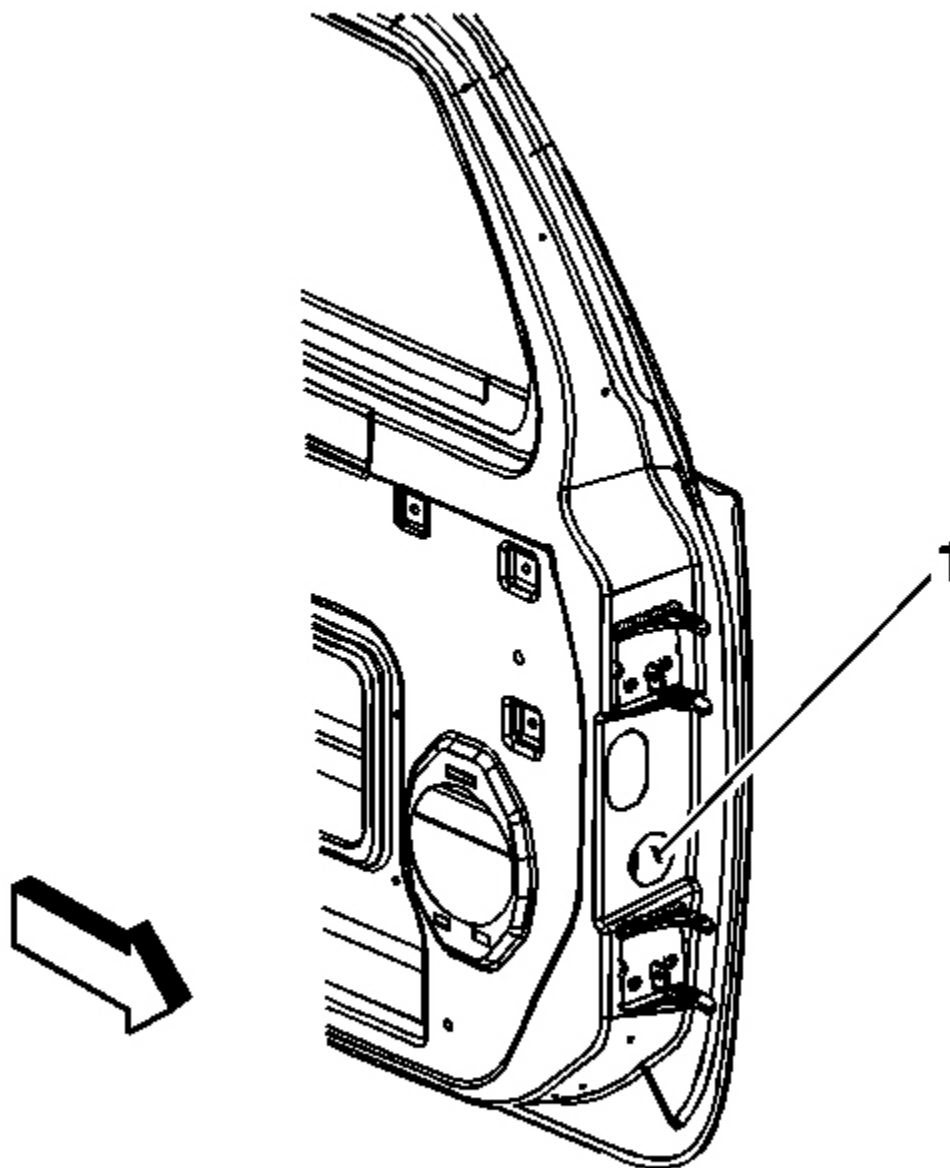

Fig. 91: Front Door Wiring Harness
Courtesy of GENERAL MOTORS CORP.

6. Remove the wiring harness from the door through the pass-through hole (1) by releasing all retainers and noting their location for reinstallation.
7. Disconnect the wiring harness from the body harness.

Installation Procedure

1. Connect the wiring harness to the body harness.

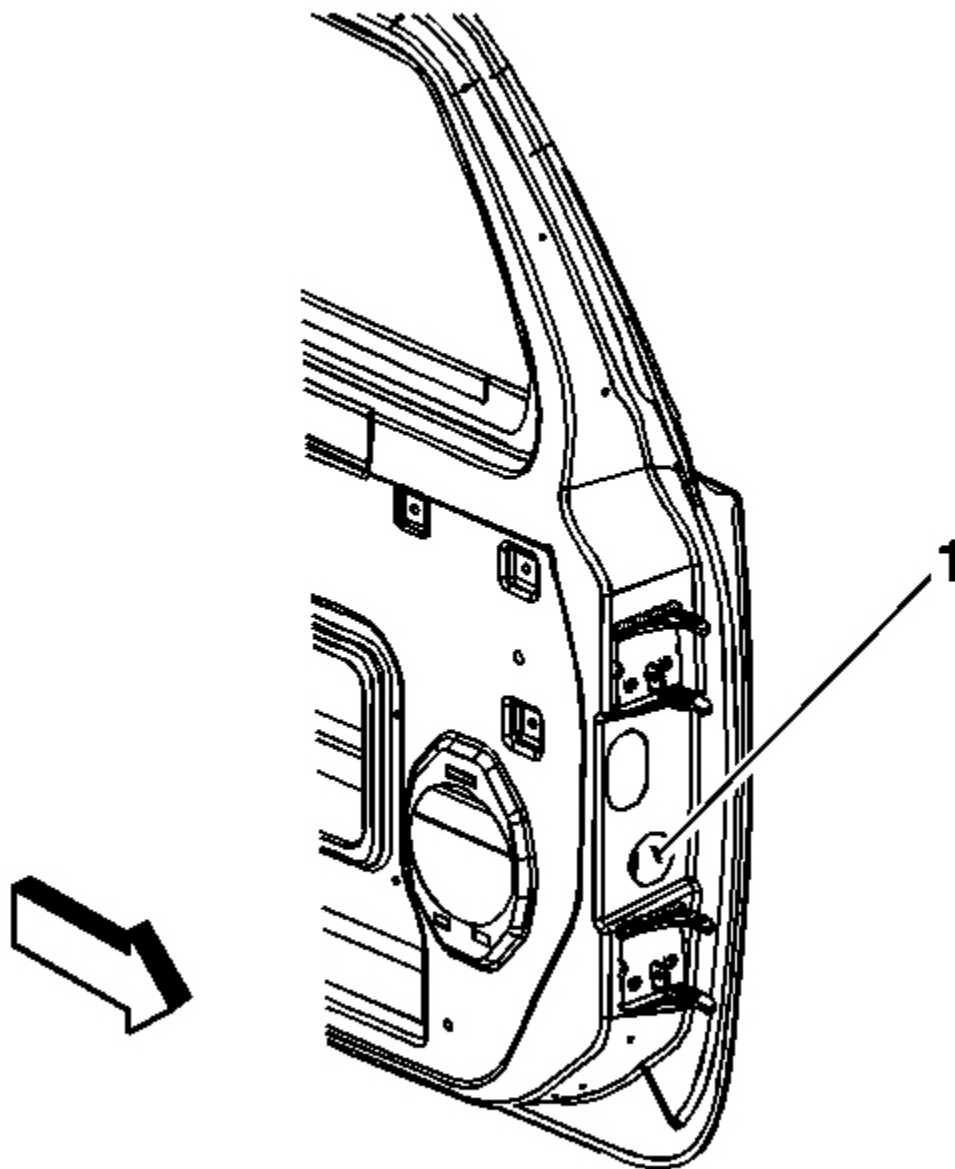

Fig. 92: Front Door Wiring Harness
Courtesy of GENERAL MOTORS CORP.

2. Route the wiring harness through the pass-through hole (1), ensuring that the rubber grommet seal is fully seated.
3. Fasten the wiring harness to the door by attaching all retainers in their proper location.
4. Connect the power mirror electrical connector.
5. Connect the door lock actuator electrical connector.
6. Connect the window motor electrical connector.
7. Connect the speaker electrical connector.
8. Operate all electrical door components to ensure proper operation.
9. Install the water deflector. Refer to **Water Deflector Replacement - Front Door** .
10. Install the door trim panel. Refer to **Trim Panel Replacement - Side Front Door** .

WIRING HARNESS REPLACEMENT - REAR DOOR

Removal Procedure

1. Remove the door trim panel. Refer to **Trim Panel Replacement - Side Rear Door** .
2. Remove the water deflector. Refer to **Water Deflector Replacement - Rear Door** .
3. Disconnect the speaker electrical connector.
4. Disconnect the window motor electrical connector.
5. Disconnect the door lock actuator electrical connector.
6. Remove the wiring harness from door through the pass through hole (2) by releasing all retainers, noting their location for reinstallation.

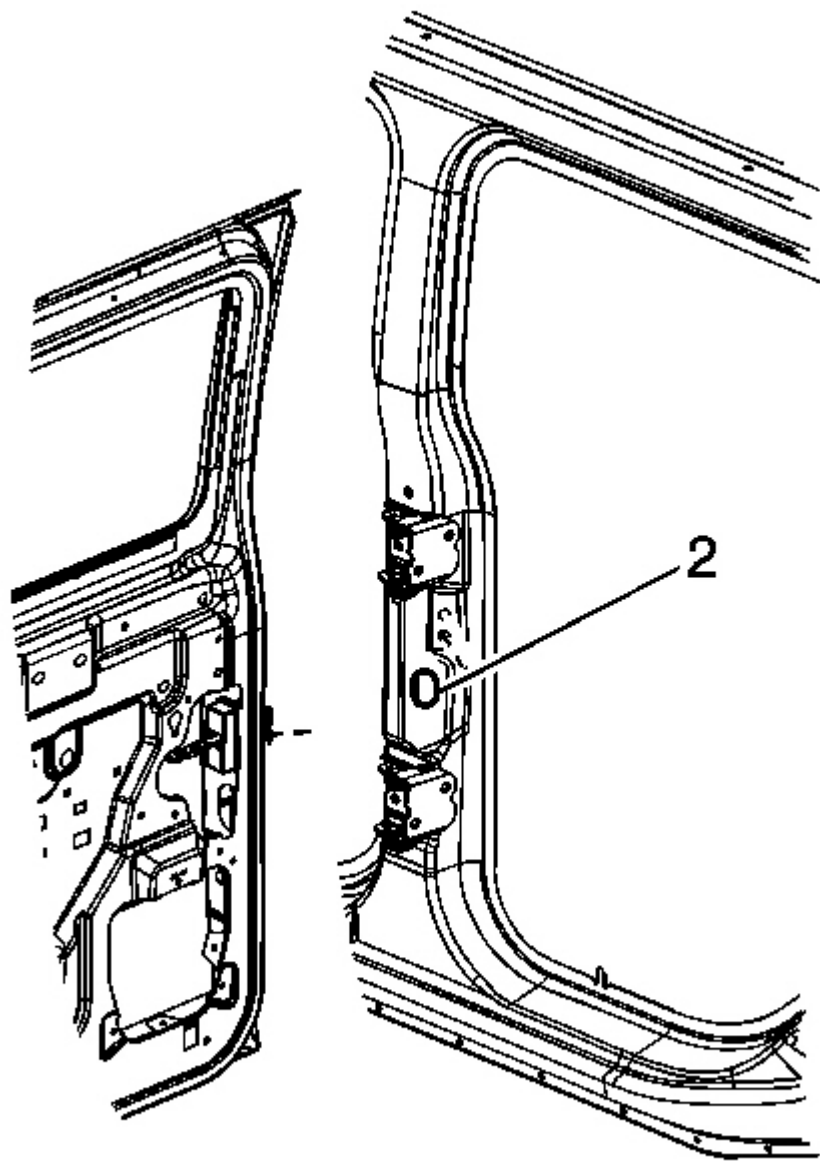

Fig. 93: Rear Door Wiring Harness
Courtesy of GENERAL MOTORS CORP.

7. Disconnect the door harness from the body harness (2).

Installation Procedure

1. Route the wiring harness through the pass through hole (2), ensuring that the rubber grommet seal is fully seated.

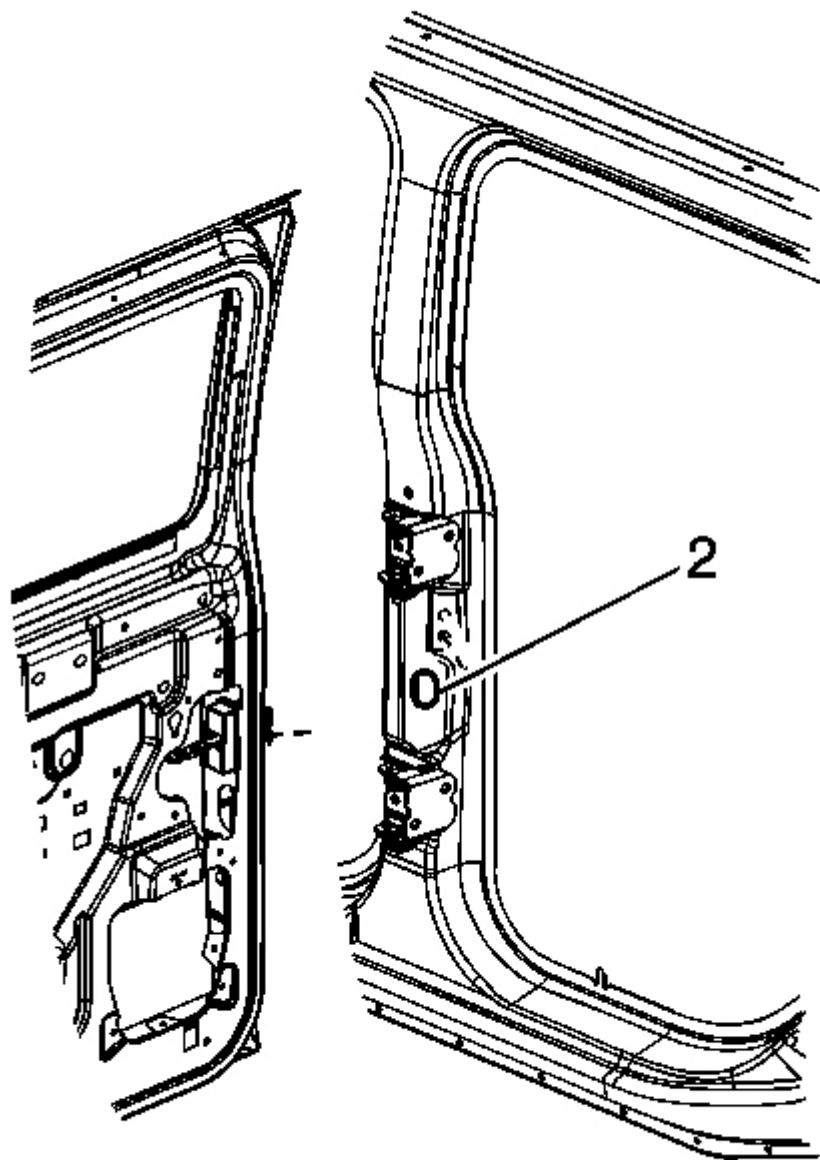

Fig. 94: Rear Door Wiring Harness
Courtesy of GENERAL MOTORS CORP.

2. Connect the door harness to the body harness (2).
3. Fasten the wiring harness to the door by attaching all retainers in their proper location.
4. Connect the door lock actuator electrical connector.
5. Connect the window motor electrical connector.
6. Connect the speaker electrical connector.
7. Operate all electrical door components to ensure proper operation.
8. Install the water deflector. Refer to **Water Deflector Replacement - Rear Door** .
9. Install the door trim panel. Refer to **Trim Panel Replacement - Side Rear Door** .

MODULE REPLACEMENT - FRONT POWER WINDOW

Removal Procedure

1. Remove the trim panel. Refer to **Trim Panel Replacement - Side Front Door** .
2. Remove the water deflector. Refer to **Water Deflector Replacement - Front Door** .
3. Position the window in a position that allows access to the window clamp bolts.

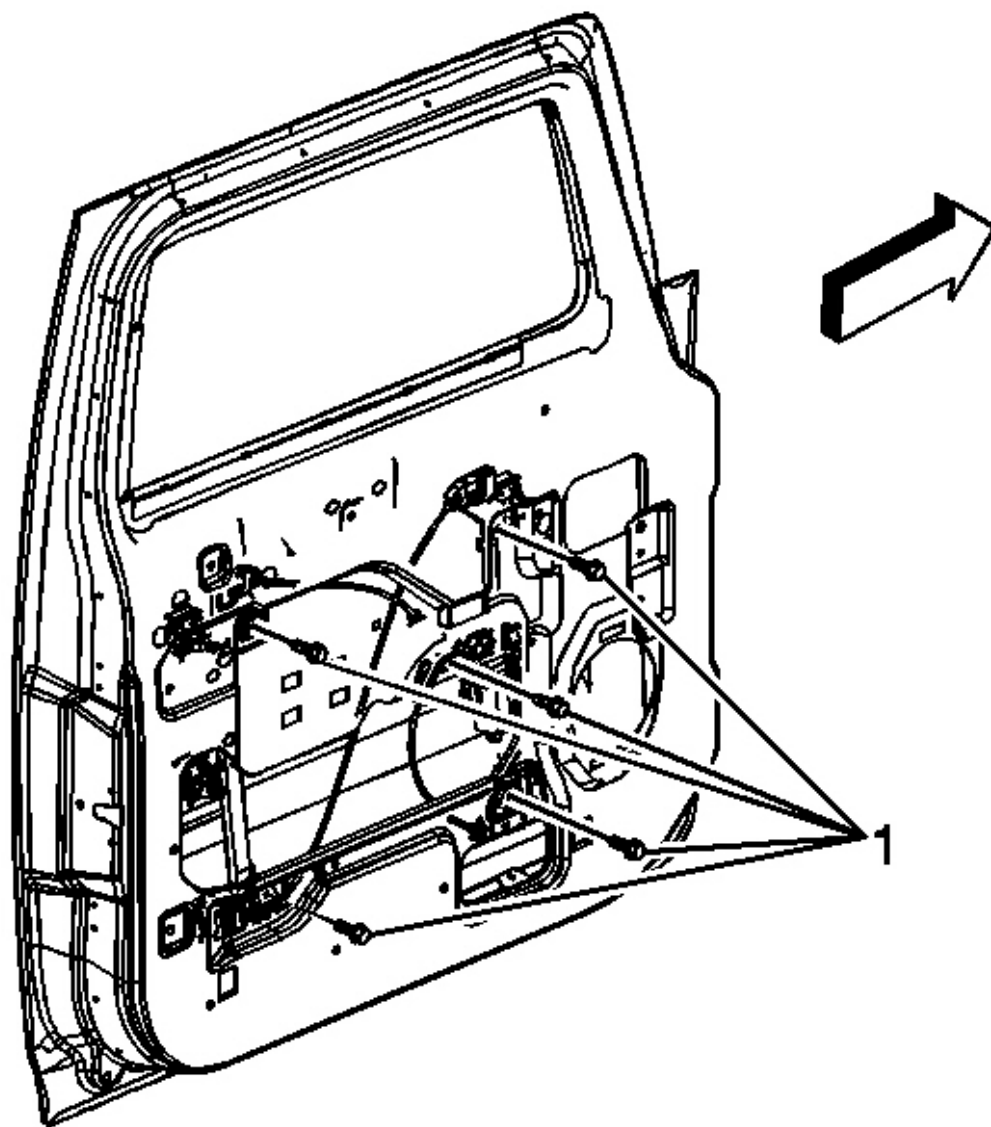

Fig. 95: Front Power Window Module
Courtesy of GENERAL MOTORS CORP.

4. Loosen the fasteners on the window clamps.
5. Position the window in the full up position and tape in place.
6. Disconnect the window motor electrical connector.
7. Remove the 5 fasteners (1) retaining the window module to the door.

8. Remove the window module from the door.

Installation Procedure

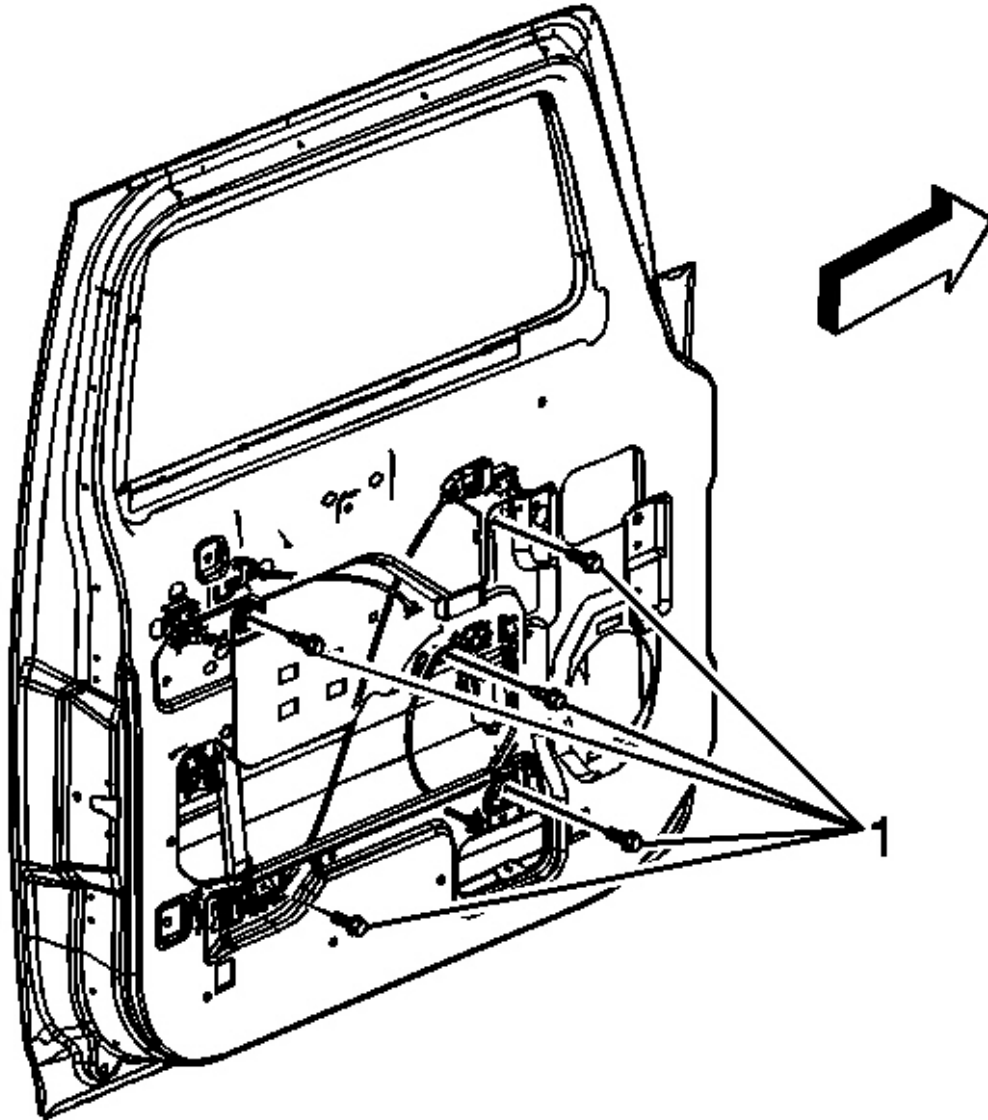

Fig. 96: Front Power Window Module
Courtesy of GENERAL MOTORS CORP.

1. Place the window module in position in the door.

NOTE: Refer to **Fastener Notice** in **Cautions and Notices**.

2. Install the 5 fasteners (1) to the window regulator.

Tighten: Tighten the fasteners to 9 N.m (7 lb ft).

3. Connect the window motor electrical connector.
4. Place the window in the window clamps, and tighten the clamps.

Tighten: Tighten the clamps to 9 N.m (7 lb ft).

5. Operate the window module to inspect for proper operation.
6. Install the water deflector. Refer to **Water Deflector Replacement - Front Door** .
7. Install the trim panel. Refer to **Trim Panel Replacement - Side Front Door** .

MODULE REPLACEMENT - REAR POWER WINDOW

Removal Procedure

1. Remove the trim panel. Refer to **Trim Panel Replacement - Side Rear Door** .
2. Remove the water deflector. Refer to **Water Deflector Replacement - Rear Door** .
3. Position the window in a position that allows access to the window clamp bolts.

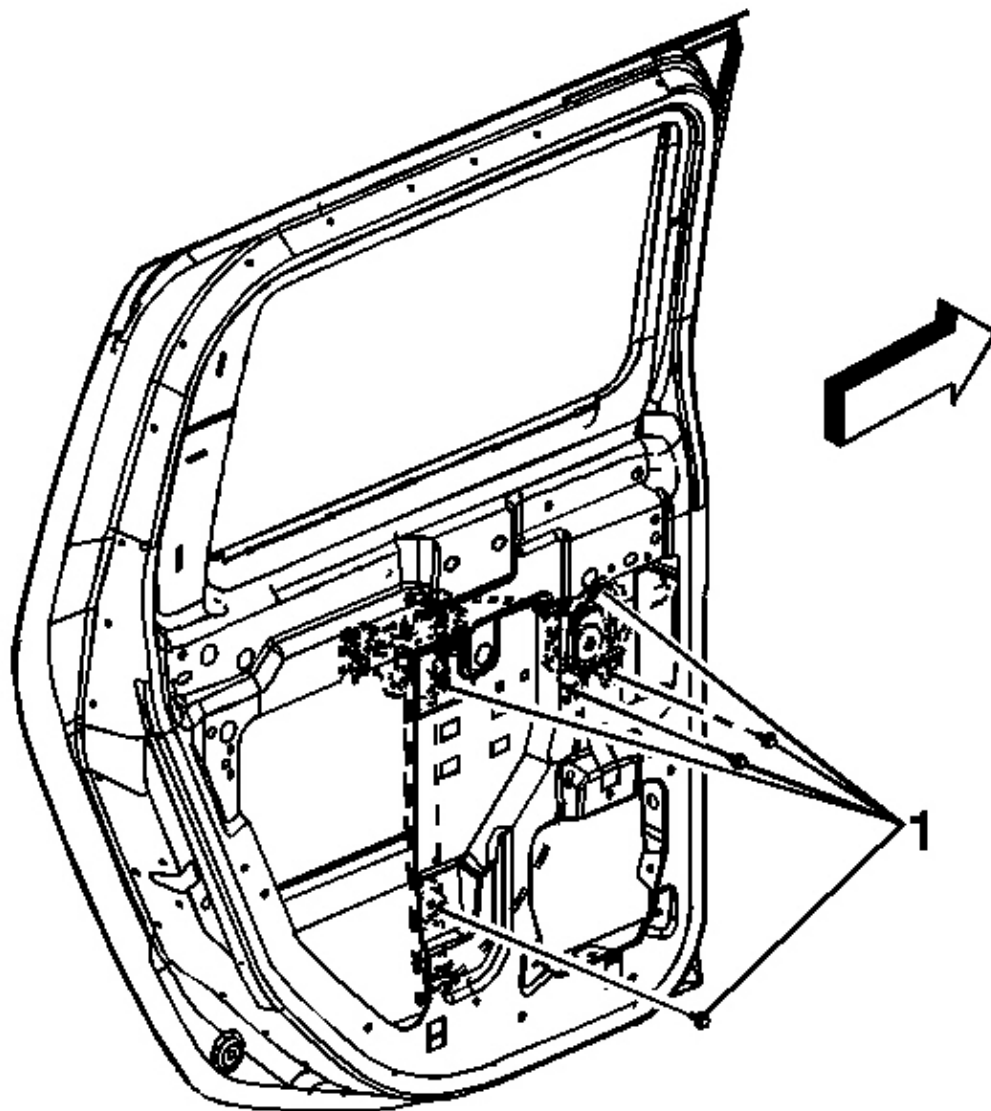

Fig. 97: Rear Power Window Module
Courtesy of GENERAL MOTORS CORP.

4. Disconnect the window motor electrical connector.
5. Position the window in the full up position and tape in place.
6. Slightly loosen the fasteners on the window clamps.
7. Remove the 5 fasteners (1) retaining the window module to the door.

8. Remove the window module from the door.

Installation Procedure

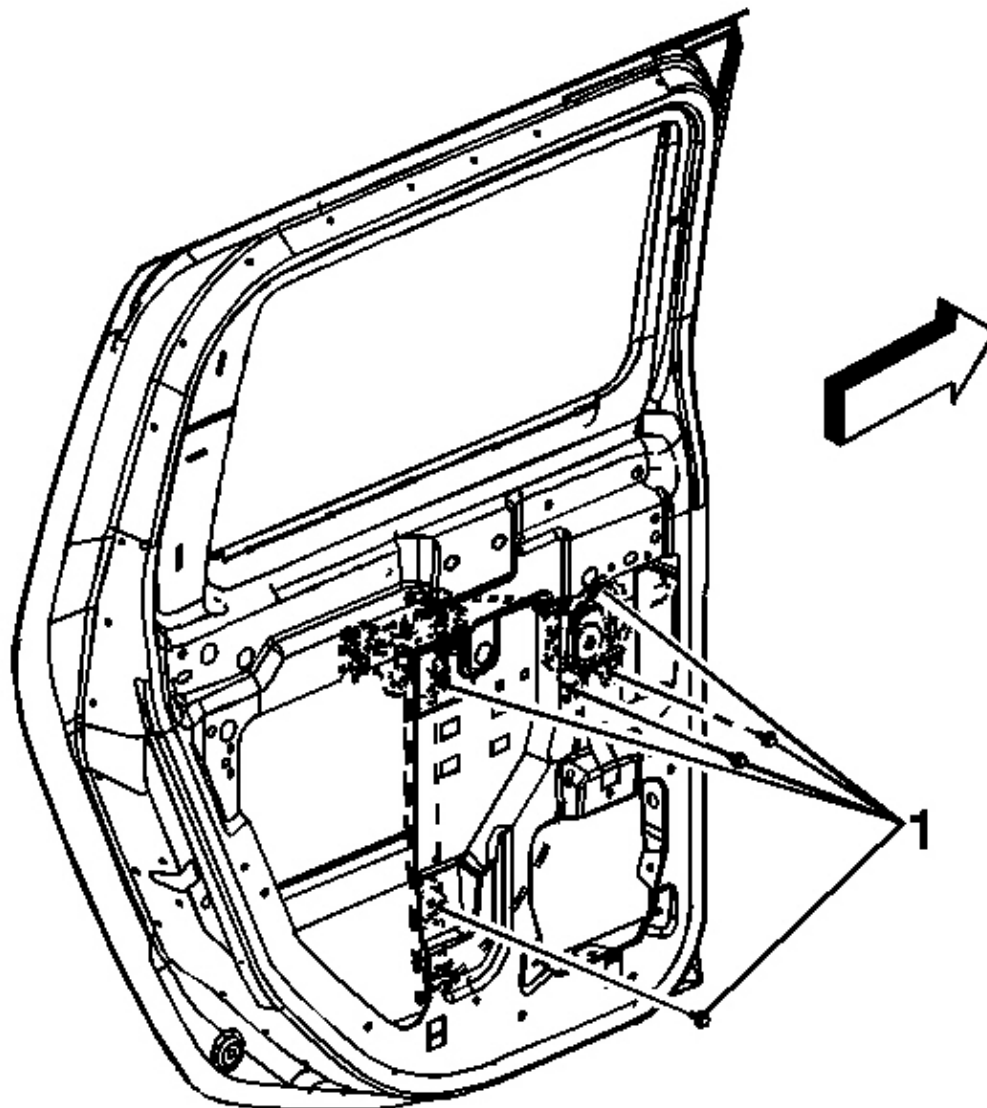

Fig. 98: Rear Power Window Module
Courtesy of GENERAL MOTORS CORP.

1. Place the window module in position in the door.

NOTE: Refer to Fastener Notice in Cautions and Notices.

2. Install the 5 fasteners (1) to the window regulator.

Tighten: Tighten the fasteners to 9 N.m (7 lb ft).

3. Place the window in the window clamps, and tighten the clamps.

Tighten: Tighten the clamps to 9 N.m (7 lb ft).

4. Connect the window motor electrical connector.
5. Operate the window module to inspect for proper operation.
6. Install the water deflector. Refer to Water Deflector Replacement - Front Door .
7. Install trim panel. Refer to Trim Panel Replacement - Side Front Door .

WINDOW REGULATOR MOTOR REPLACEMENT - FRONT DOOR

Removal Procedure

1. Remove the window module. Refer to Module Replacement - Front Power Window .

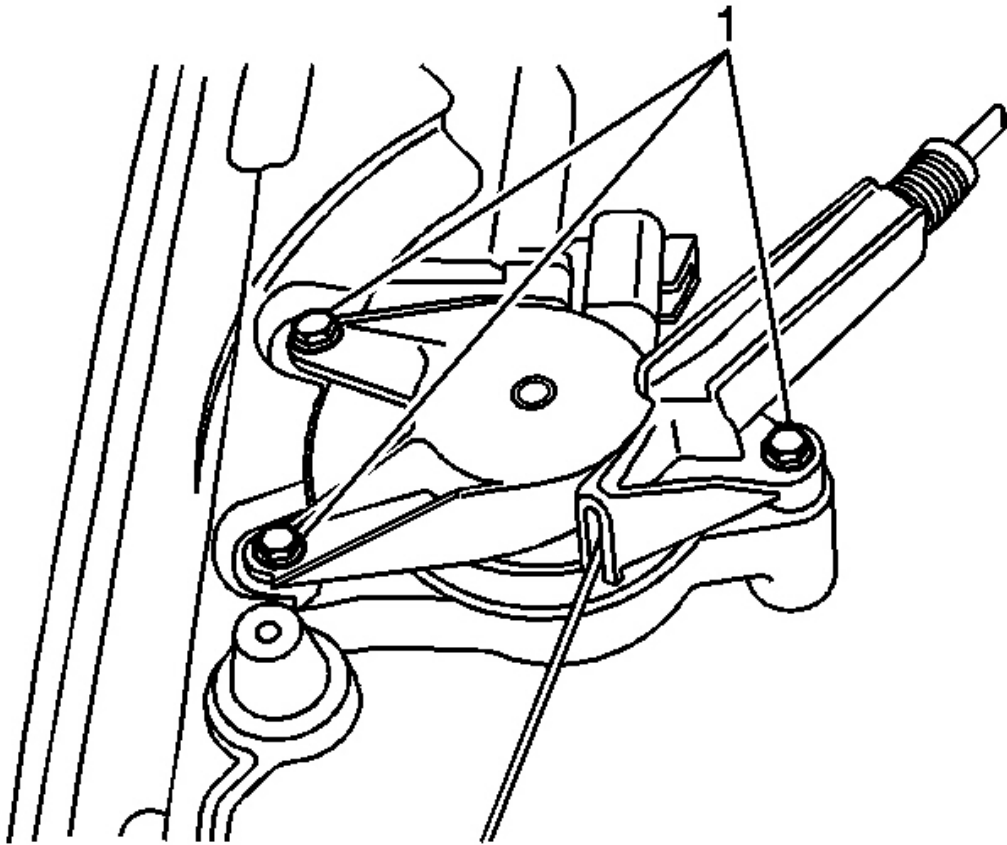

Fig. 99: Window Regulator Motor (Front Door)
Courtesy of GENERAL MOTORS CORP.

2. Remove the 3 fasteners (1) retaining the motor to the module.
3. Remove the window motor.

Installation Procedure

1. Place the window motor into position on the window module.

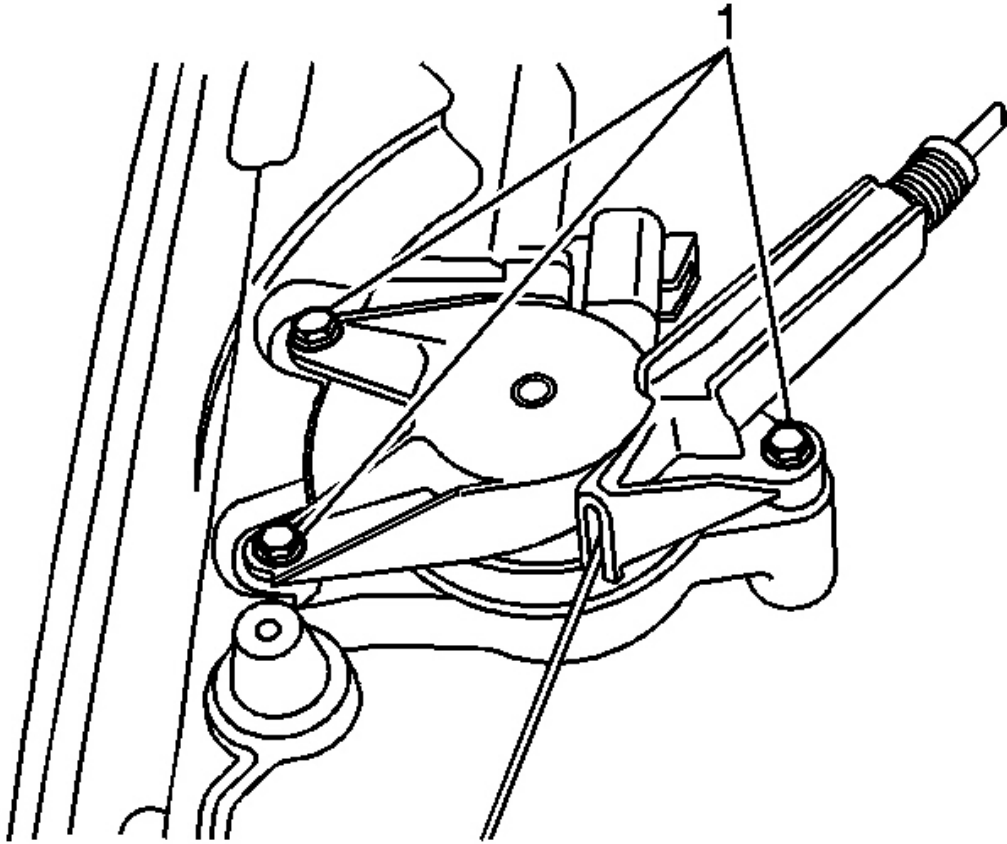

Fig. 100: Window Regulator Motor (Front Door)
Courtesy of GENERAL MOTORS CORP.

2. Install the 3 fasteners (1) retaining the window motor to the window module.
3. Install the window module. Refer to **Module Replacement - Front Power Window** .
4. Operate the window to ensure proper operation.

WINDOW REGULATOR MOTOR REPLACEMENT - REAR DOOR

Removal Procedure

1. Remove the window module. Refer to **Module Replacement - Rear Power Window** .

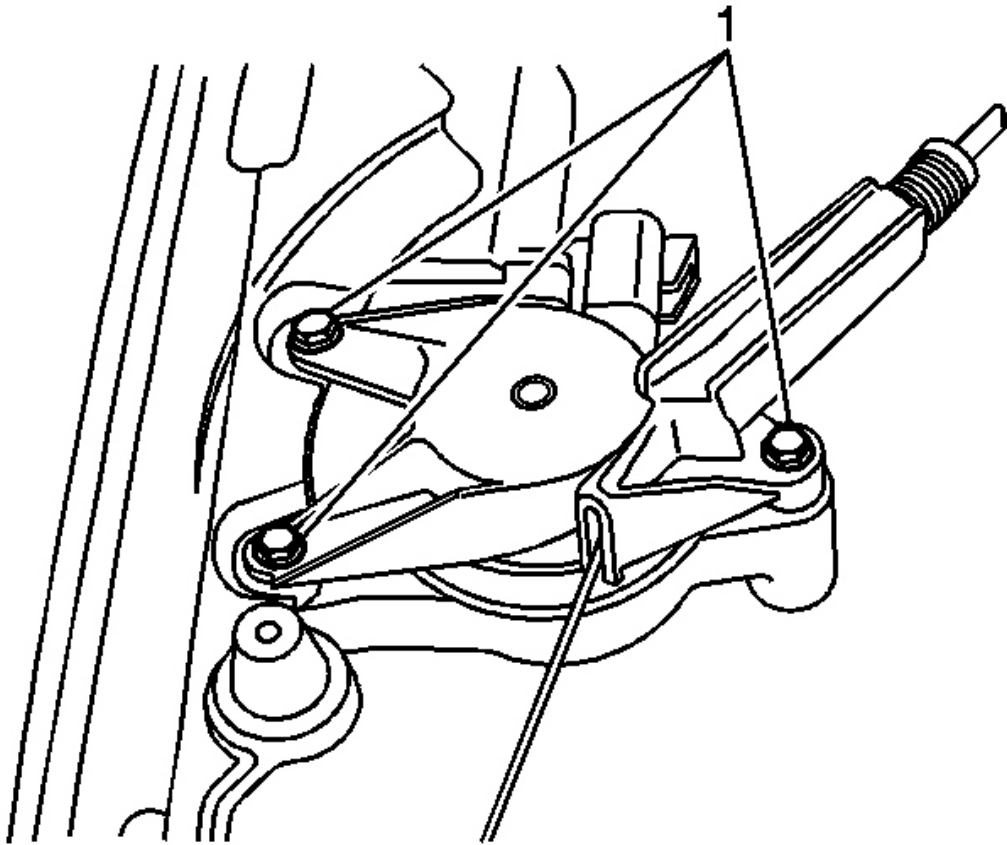

Fig. 101: Window Regulator Motor (Rear Door)
Courtesy of GENERAL MOTORS CORP.

2. Remove the 3 fasteners (1) retaining the motor to the module.
3. Remove the window motor.

Installation Procedure

1. Place the window motor into position on the window module.

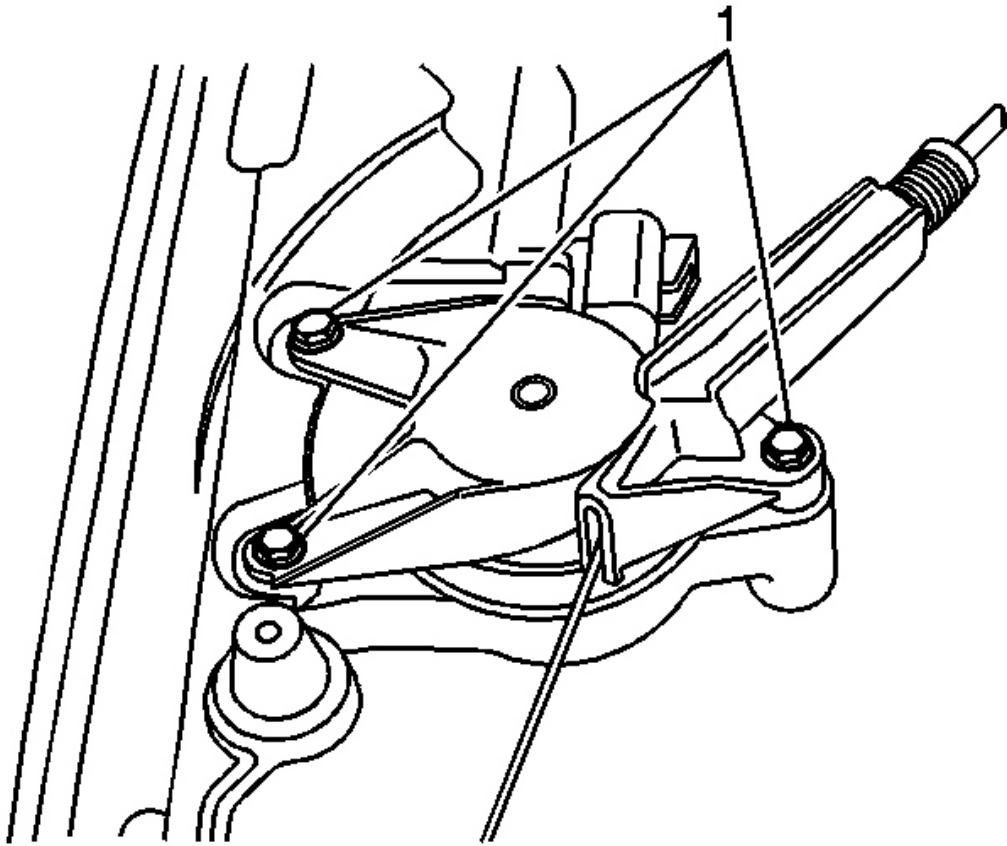

Fig. 102: Window Regulator Motor (Rear Door)
Courtesy of GENERAL MOTORS CORP.

2. Install the 3 fasteners (1) retaining the window motor to the window module.
3. Install the window module. Refer to **Module Replacement - Rear Power Window** .
4. Operate the window to ensure proper operation.

WINDOW REPLACEMENT - FRONT DOOR

Removal Procedure

1. Remove the door trim panel. Refer to **Trim Panel Replacement - Side Front Door** .
2. Remove the water deflector. Refer to **Water Deflector Replacement - Front Door** .

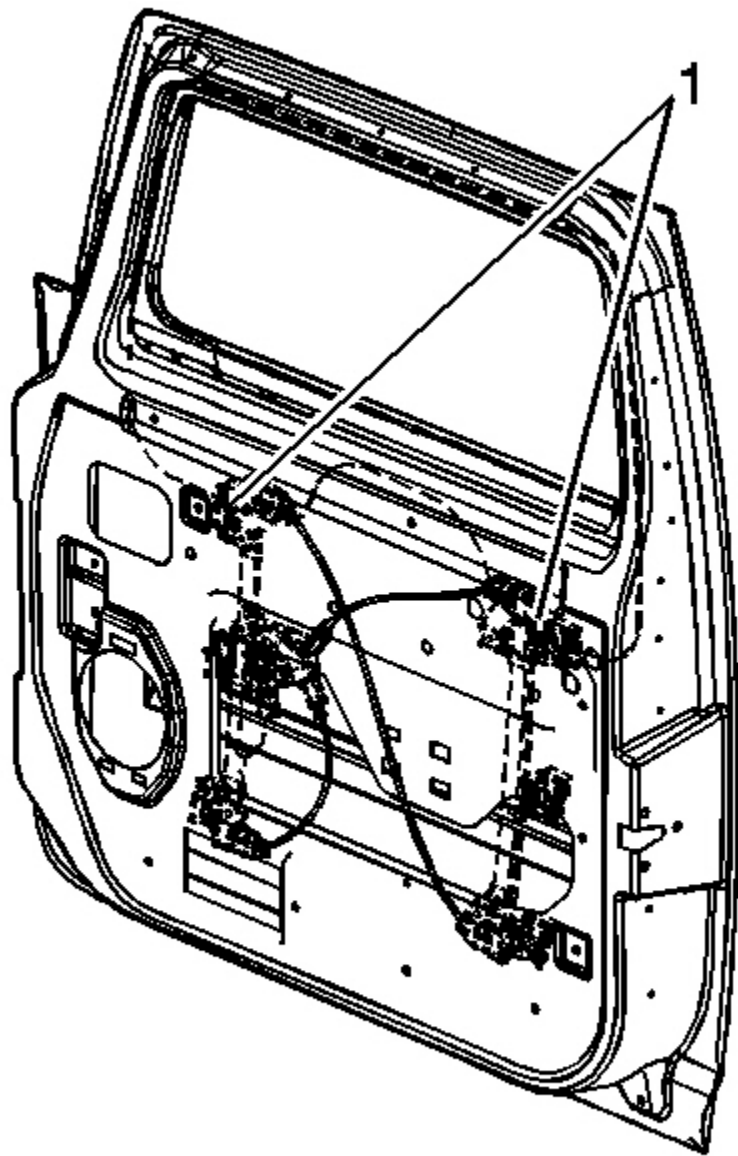

Fig. 103: Front Door Window
Courtesy of GENERAL MOTORS CORP.

3. Loosen the clamps (1) securing the window to the window module.
4. Remove the outer window belt sealing strip. Refer to **Sealing Strip Replacement - Front Door Window Belt Outer - Front** .

5. Remove the window through the bottom of the window frame.

Installation Procedure

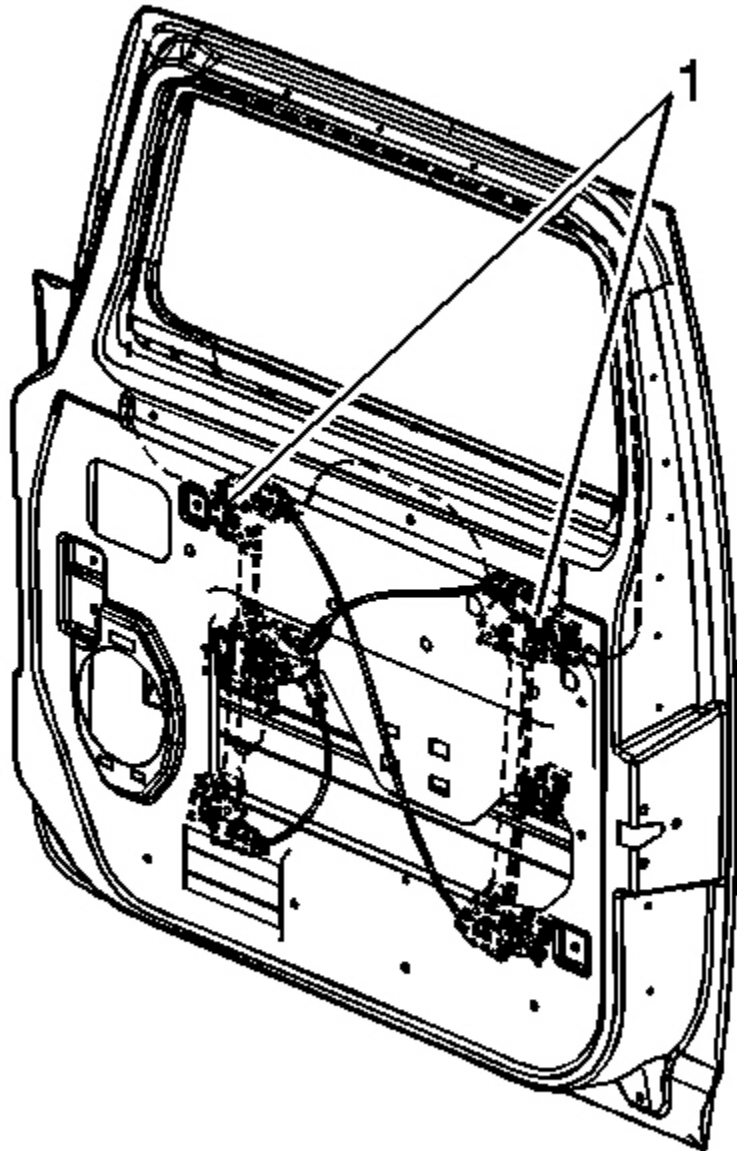

Fig. 104: Front Door Window
Courtesy of GENERAL MOTORS CORP.

1. Slide the window through the opening of the window frame into position into the window clamps (1).
2. Install the outer window belt sealing strip. Refer to **Sealing Strip Replacement - Front Door Window Belt Outer - Front** .

NOTE: Refer to **Fastener Notice** in **Cautions and Notices**.

3. Install the water deflector. Refer to **Water Deflector Replacement - Front Door** .

Tighten: Tighten the clamps to 9 N.m (6 lb ft).

4. Install the door trim panel. Refer to **Trim Panel Replacement - Side Front Door** .
5. Operate the window to ensure proper operation.

WINDOW REPLACEMENT - REAR DOOR

Removal Procedure

1. Remove the door trim panel. Refer to **Trim Panel Replacement - Side Rear Door** .
2. Remove the water deflector. Refer to **Water Deflector Replacement - Rear Door** .

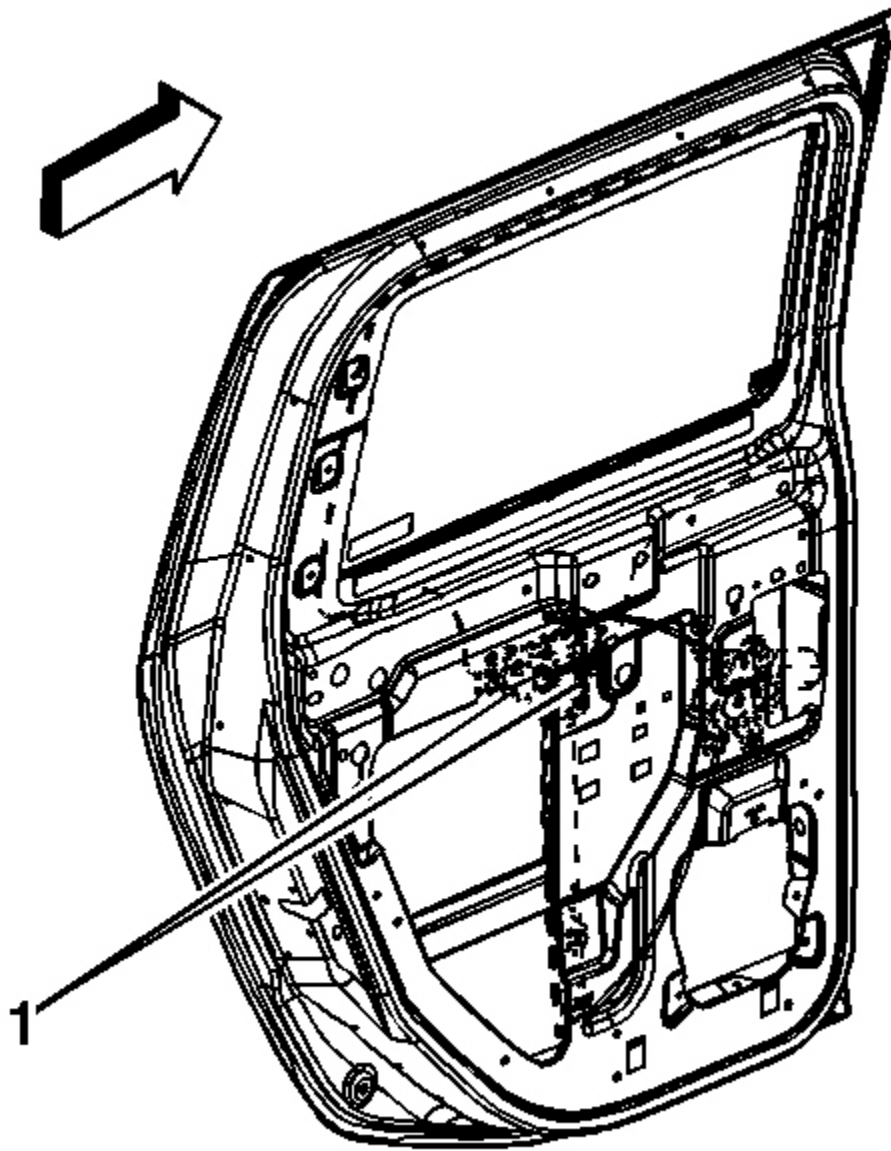

Fig. 105: Rear Door Window
Courtesy of GENERAL MOTORS CORP.

3. Remove the run channel. Refer to Window Run Channel Replacement - Rear Door .
4. Remove the stabilizer. Refer to Window Stabilizer Replacement - Rear Door .
5. Remove the outer sealing strip. Refer to Sealing Strip Replacement - Rear Door Window Belt Outer .

6. Loosen the clamps (1) securing the glass to the window module.
7. Remove the window through the opening at the bottom of the window frame.

Installation Procedure

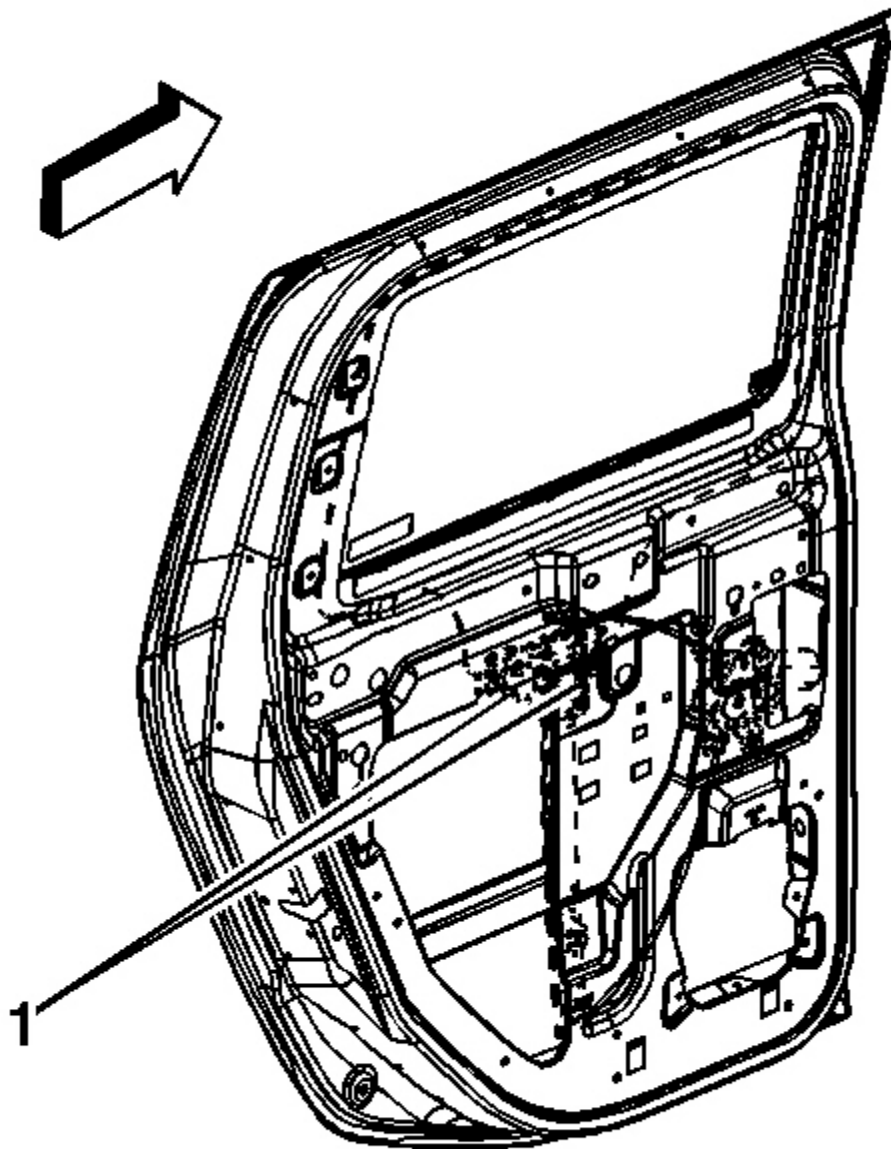

Fig. 106: Rear Door Window

Courtesy of GENERAL MOTORS CORP.

1. Slide the window through the opening at the bottom of the window frame into position in the window clamps (1).
2. Install the sealing strip. Refer to **Sealing Strip Replacement - Rear Door Window Belt Outer** .

NOTE: Refer to **Fastener Notice** in Cautions and Notices.

3. Install the run channel. Refer to **Window Run Channel Replacement - Rear Door** .

Tighten: Tighten the clamps to 9 N.m (6 lb ft).

4. Install the stabilizer. Refer to **Window Stabilizer Replacement - Rear Door** .
5. Operate the window to ensure proper operation.
6. Install the water deflector. Refer to **Water Deflector Replacement - Rear Door** .
7. Install the door trim panel. Refer to **Trim Panel Replacement - Side Rear Door** .

WINDOW RUN CHANNEL REPLACEMENT - REAR DOOR

Removal Procedure

1. Raise the window to the full up position.
2. Remove the door trim panel. Refer to **Trim Panel Replacement - Side Rear Door** .
3. Remove the water deflector. Refer to **Water Deflector Replacement - Rear Door** .

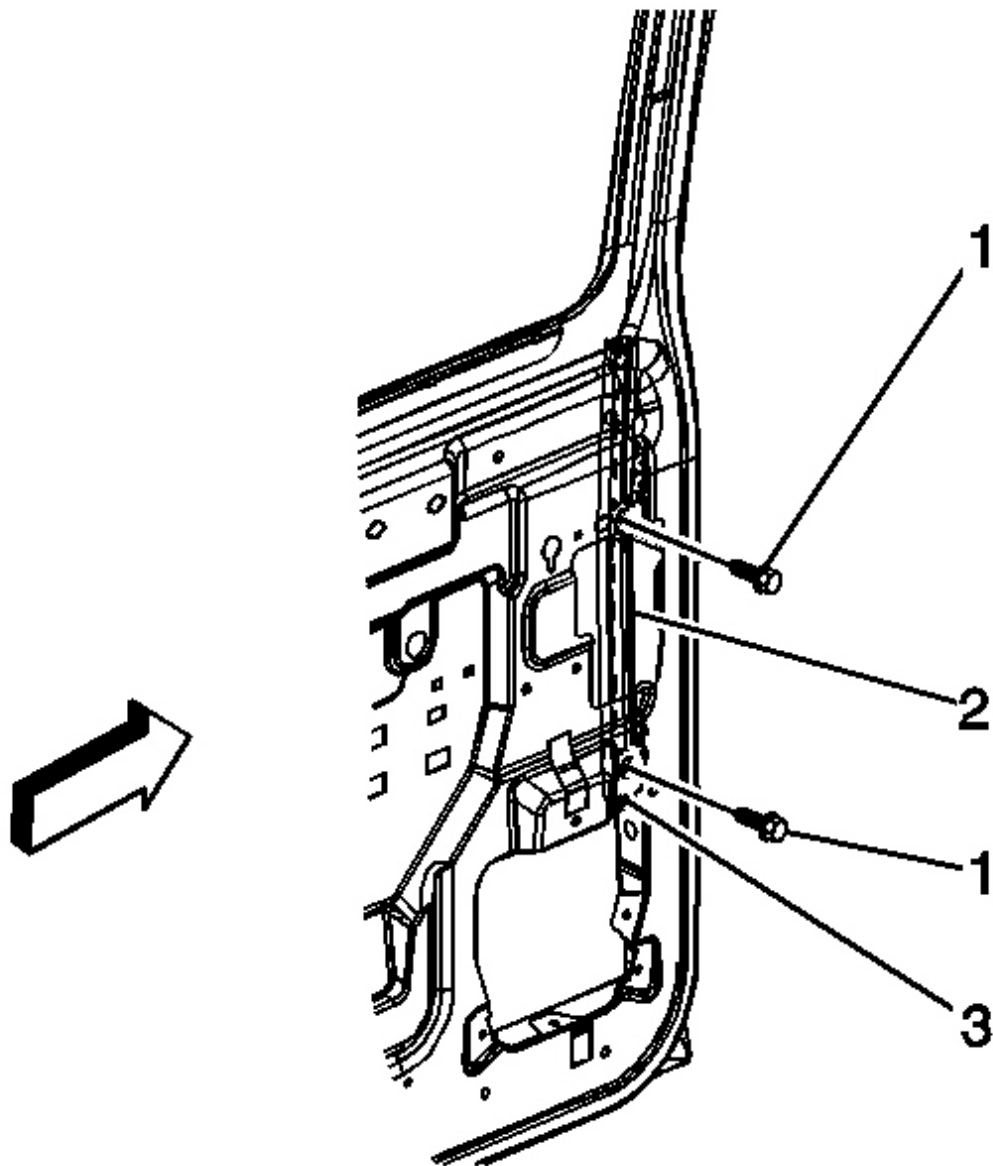

Fig. 107: Rear Door Window Run Channel
Courtesy of GENERAL MOTORS CORP.

4. Remove the 2 fasteners (1) retaining the run channel to the door.
5. Remove the run channel.

Installation Procedure

1. With the window in the full up position, position the run channel (2) in place inside the door.

NOTE: Refer to Fastener Notice in Cautions and Notices.

2. Install the fasteners (1) retaining the run channel to the door.

Tighten: Tighten the fasteners to 9 N.m (6 lb ft).

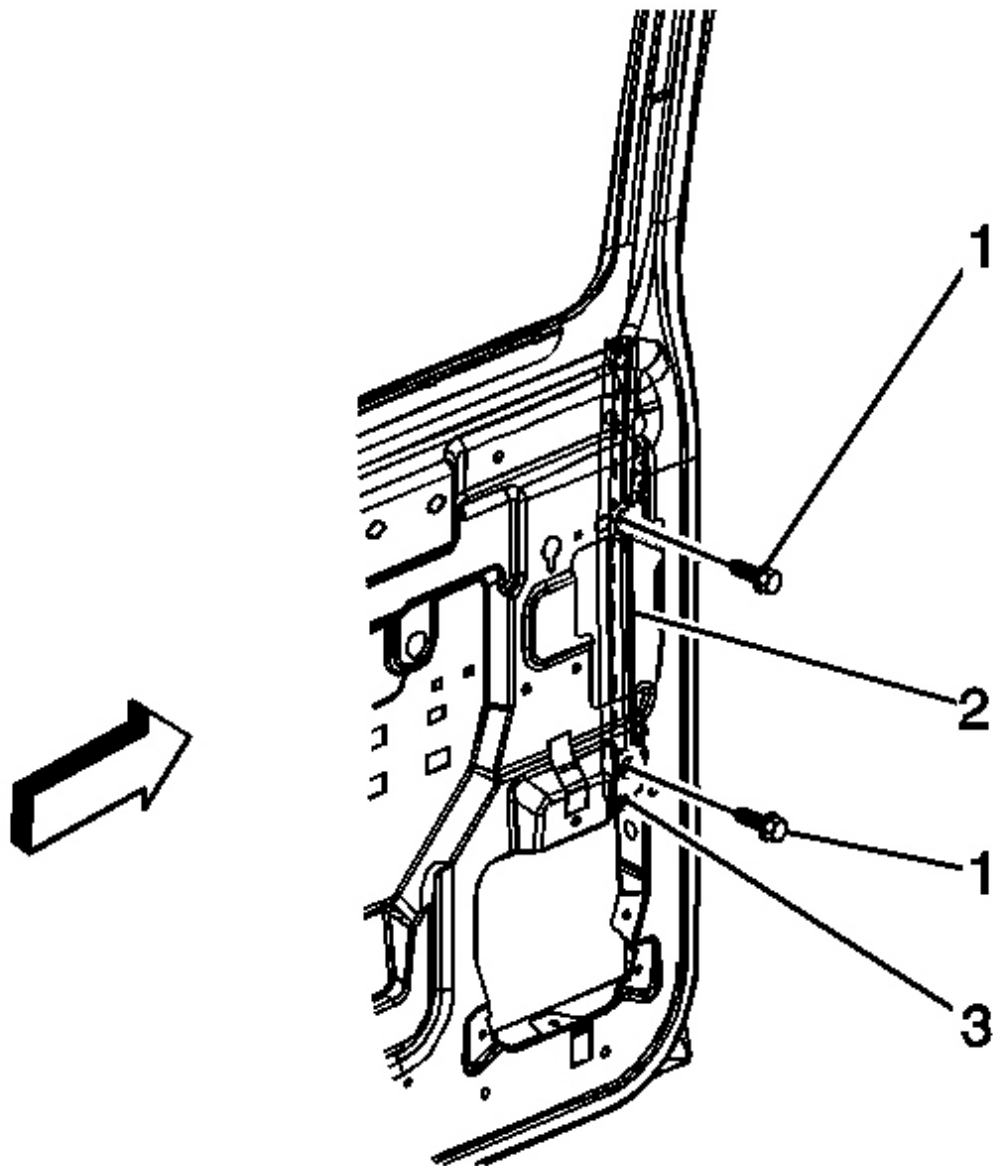

Fig. 108: Rear Door Window Run Channel
Courtesy of GENERAL MOTORS CORP.

3. Install the water deflector. Refer to **Water Deflector Replacement - Rear Door** .
4. Install the door trim panel. Refer to **Trim Panel Replacement - Side Front Door** .

WINDOW RUN CHANNEL REPLACEMENT - FRONT DOOR

Removal Procedure

1. Raise the window to the full up position.
2. Remove the door trim panel. Refer to Trim Panel Replacement - Side Front Door .
3. Remove the water deflector. Refer to Water Deflector Replacement - Front Door .

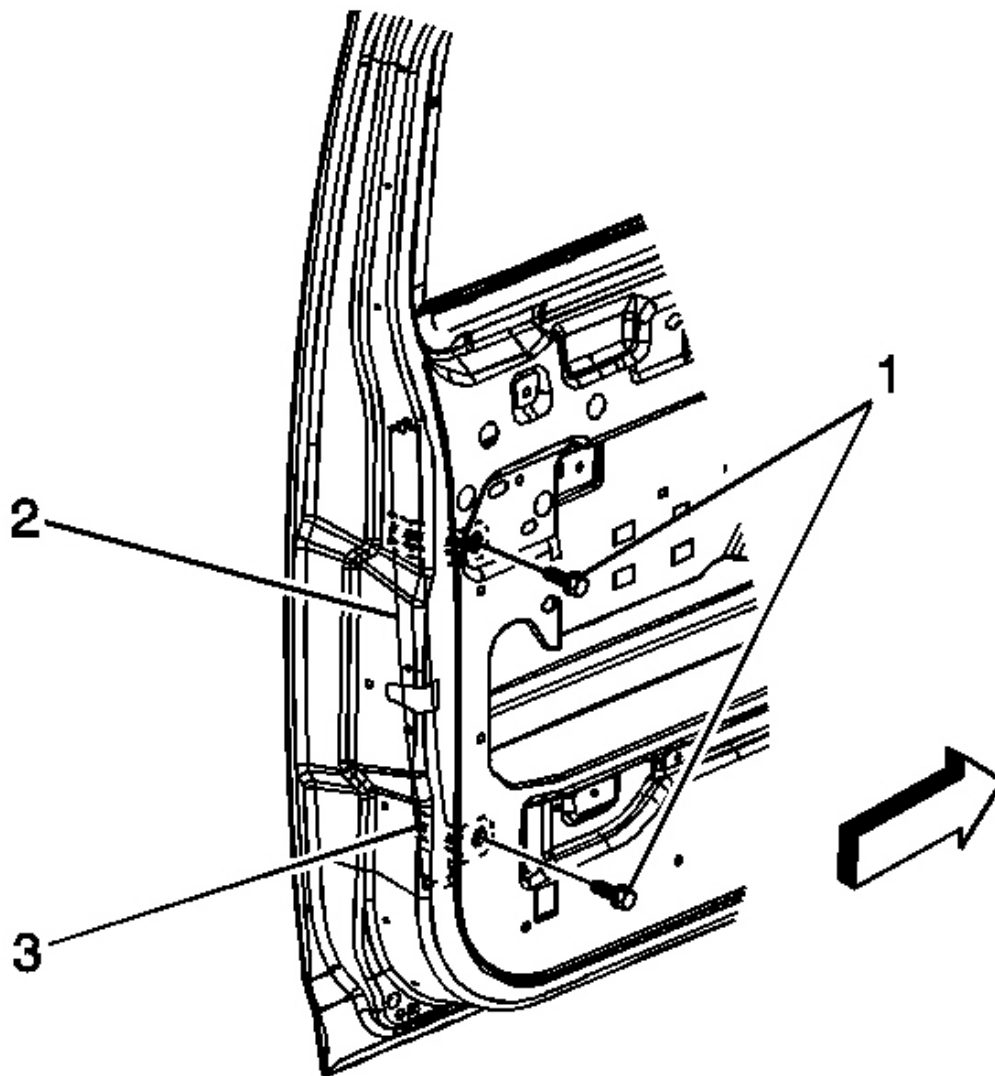

Fig. 109: Front Door Window Run Channel

Courtesy of GENERAL MOTORS CORP.

4. Remove the 2 fasteners (1) retaining the run channel to the door.
5. Remove the run channel (2).

Installation Procedure

1. Position the run channel (2) in place inside the door.

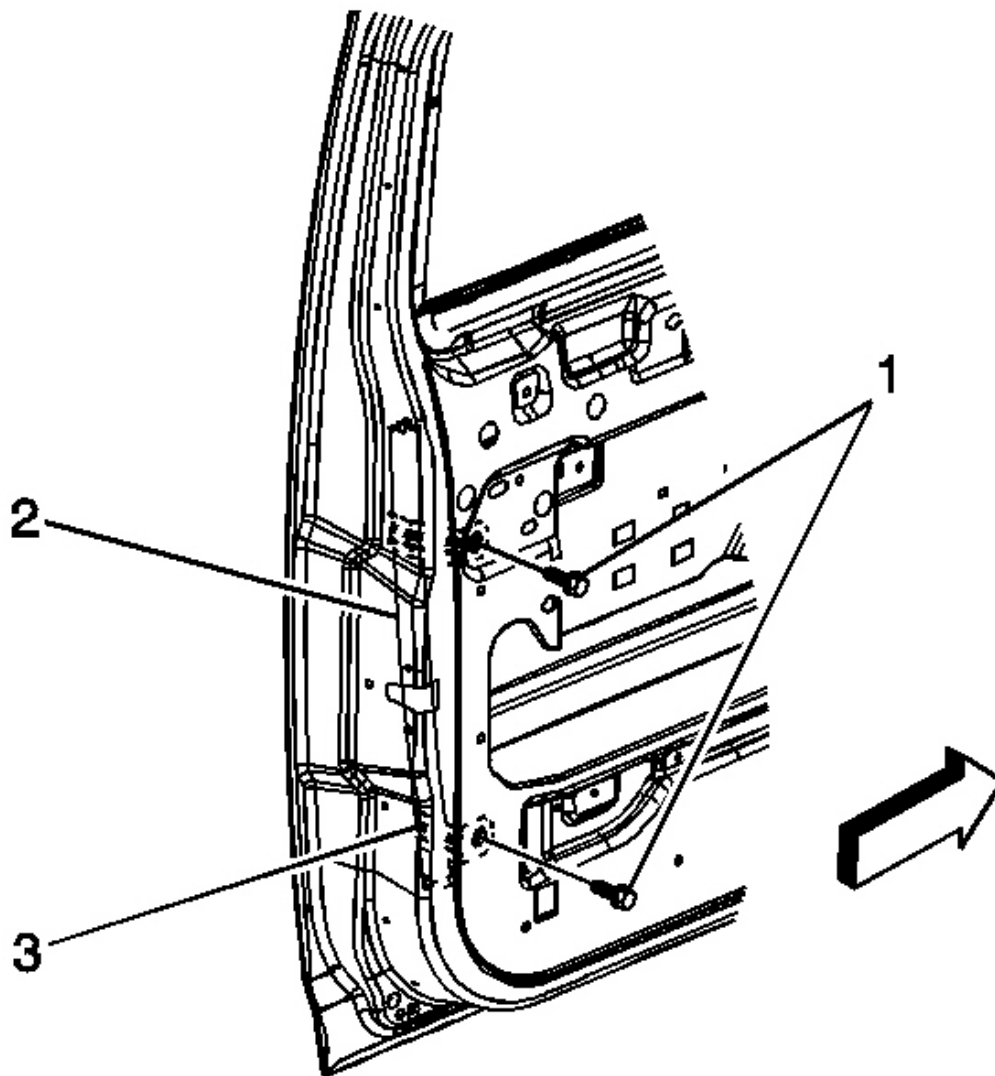

Fig. 110: Front Door Window Run Channel
Courtesy of GENERAL MOTORS CORP.

NOTE: Refer to Fastener Notice in Cautions and Notices.

2. Install the fasteners (1) retaining the run channel to the door.

Tighten: Tighten the fasteners to 9 N.m (7 lb ft).

3. Install water deflector. Refer to Water Deflector Replacement - Front Door .
4. Install the door trim panel. Refer to Trim Panel Replacement - Side Front Door .

WINDOW STABILIZER REPLACEMENT - FRONT DOOR

Removal Procedure

1. Remove the door trim panel. Refer to Trim Panel Replacement - Side Front Door .
2. Remove the water deflector. Refer to Water Deflector Replacement - Front Door .

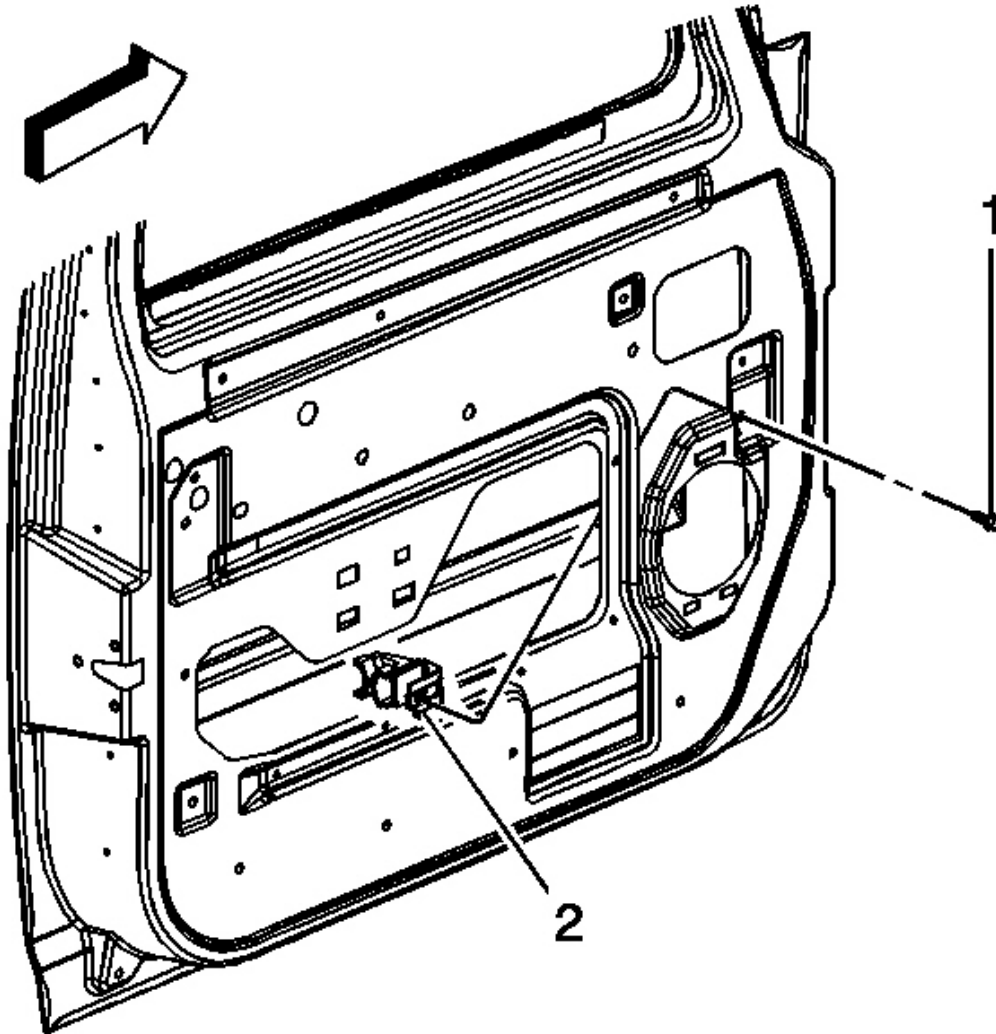

Fig. 111: Front Door Window Stabilizer
Courtesy of GENERAL MOTORS CORP.

3. Remove the fastener (1) retaining the stabilizer to the door.
4. Remove the stabilizer (2).

Installation Procedure

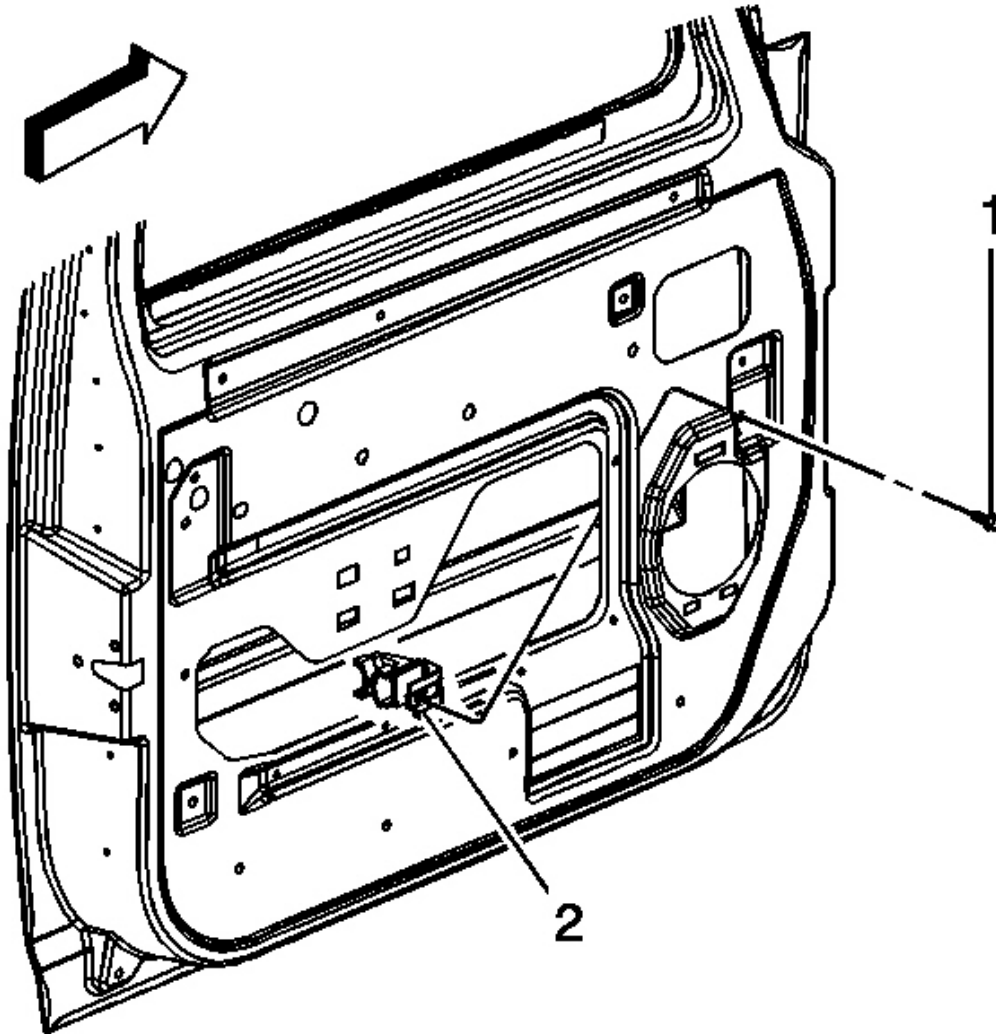

Fig. 112: Front Door Window Stabilizer
Courtesy of GENERAL MOTORS CORP.

1. Position the stabilizer (2) in place inside the door.

NOTE: Refer to Fastener Notice in Cautions and Notices.

2. Install the fastener (1) retaining the stabilizer to the door.

Tighten: Tighten the fastener to 9 N.m (7 lb ft).

3. Install the water deflector. Refer to **Water Deflector Replacement - Front Door** .
4. Install the door trim panel. Refer to **Trim Panel Replacement - Side Front Door** .

WINDOW STABILIZER REPLACEMENT - REAR DOOR

Removal Procedure

1. Position the window in the full up position.
2. Remove the door trim panel. Refer to **Trim Panel Replacement - Side Front Door** .
3. Remove the water deflector. Refer to **Water Deflector Replacement - Front Door** .

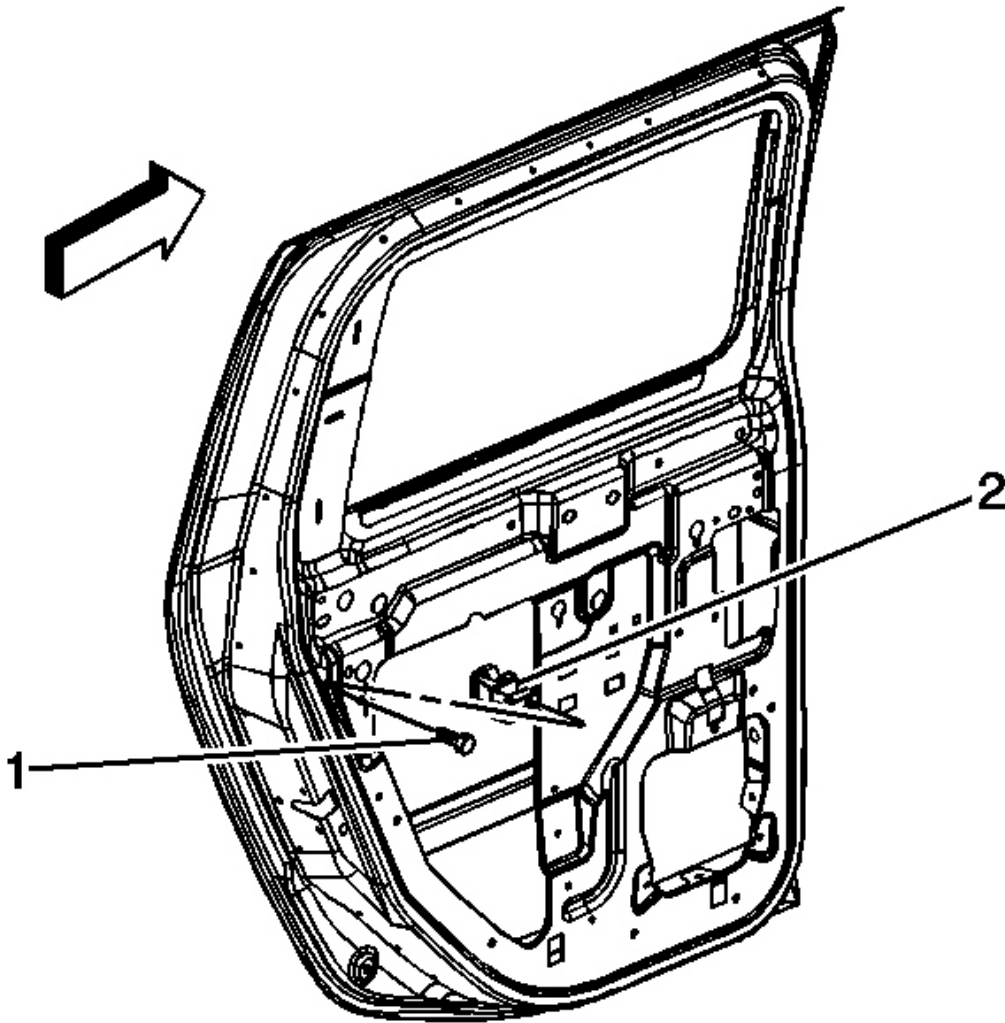

Fig. 113: Rear Door Window Stabilizer
Courtesy of GENERAL MOTORS CORP.

4. Remove the fastener (1) retaining the stabilizer to the door.
5. Remove the stabilizer (2).

Installation Procedure

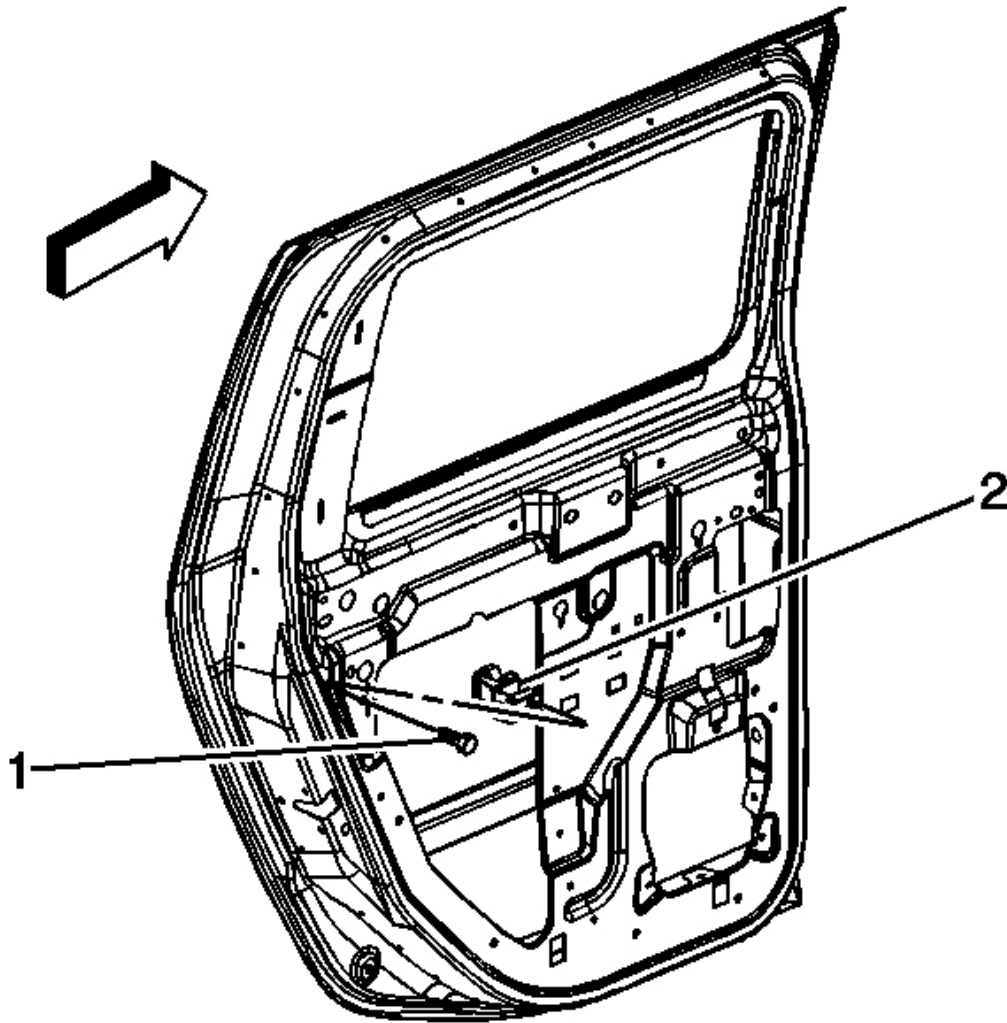

Fig. 114: Rear Door Window Stabilizer
Courtesy of GENERAL MOTORS CORP.

1. With the window in the full up position, position the stabilizer (2) in place inside the door.

NOTE: Refer to Fastener Notice in Cautions and Notices.

2. Install the fastener (1) retaining the stabilizer to the door.

Tighten: Tighten the fasteners to 9 N.m (7 lb ft).

3. Install the water deflector. Refer to Water Deflector Replacement - Front Door .
4. Install the door trim panel. Refer to Trim Panel Replacement - Side Front Door

SEALING STRIP REPLACEMENT - FRONT DOOR WINDOW BELT OUTER - FRONT

Removal Procedure

1. Lower the window to the full down position.

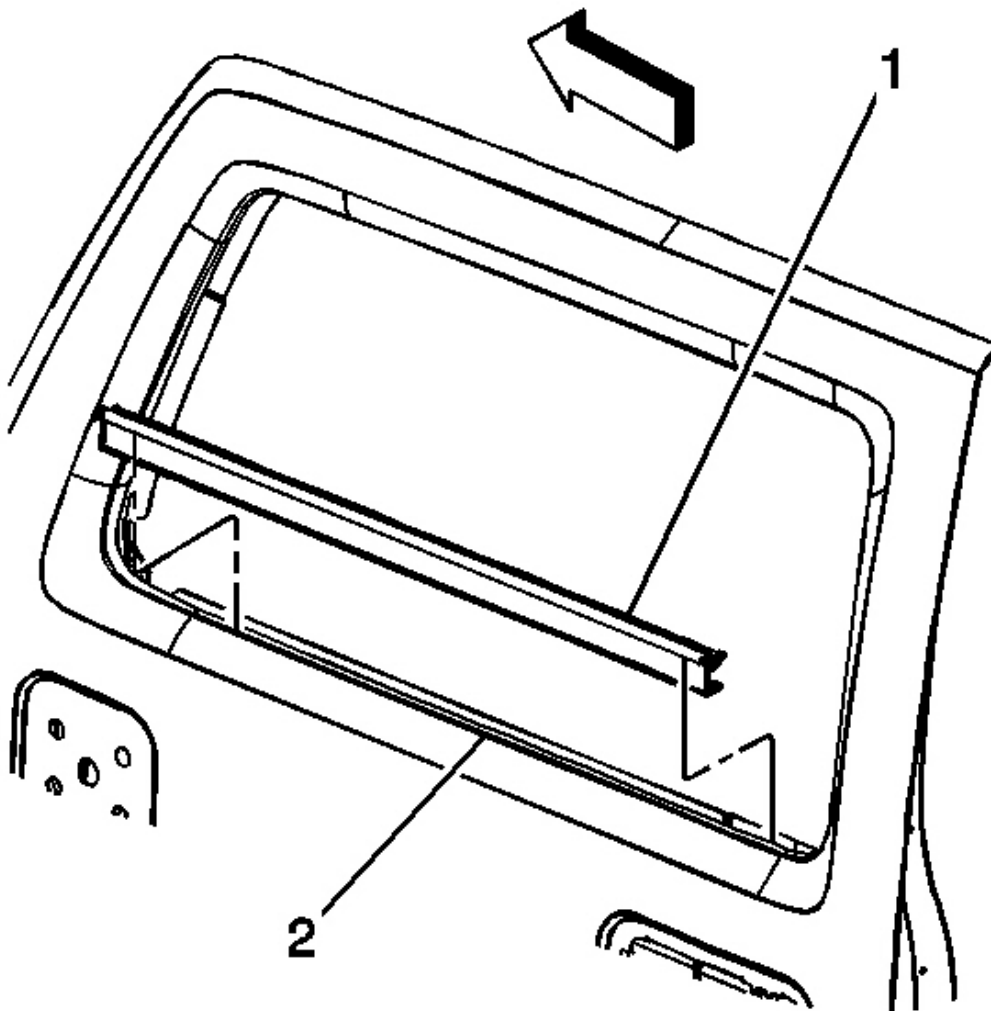

Fig. 115: Front Door Window Sealing Strip
Courtesy of GENERAL MOTORS CORP.

2. Starting at one side, carefully remove the sealing strip (1) by lifting the strip off of the pinch weld flange (2).

Installation Procedure

1. Lower the window to the full down position.

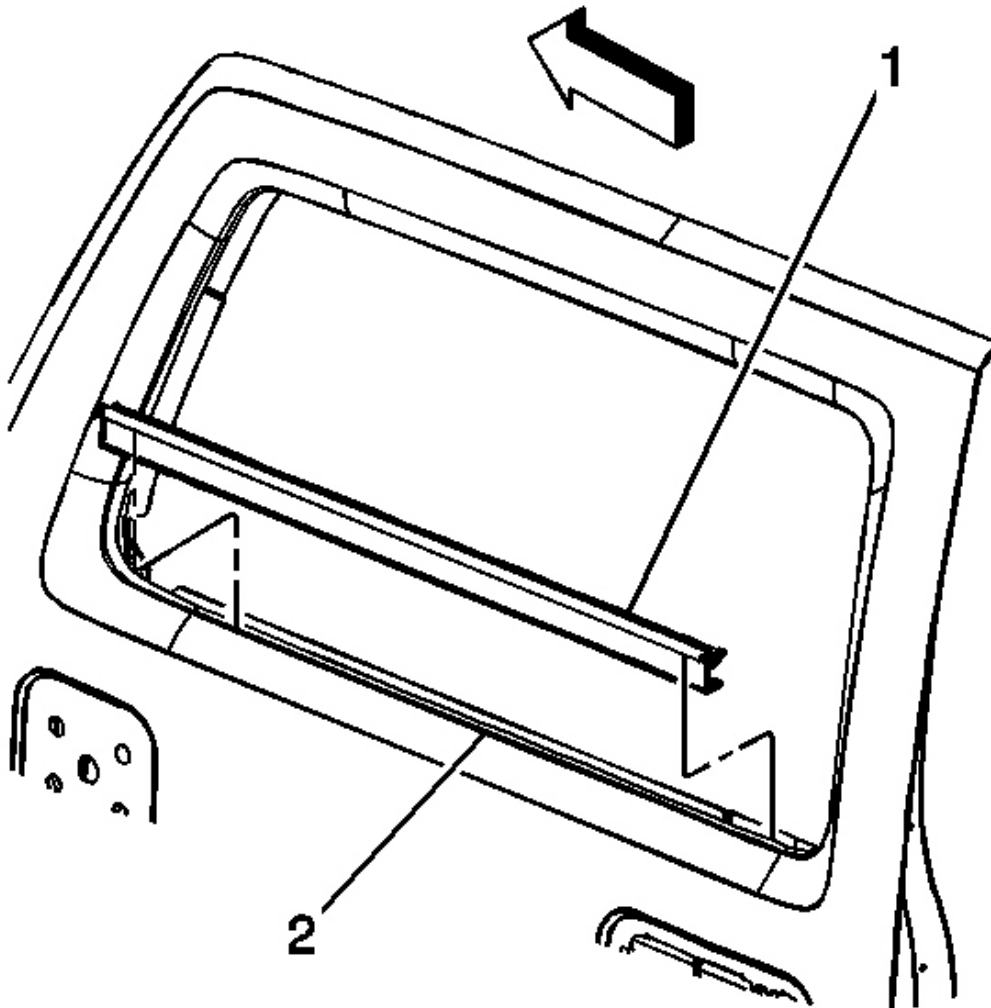

Fig. 116: Front Door Window Sealing Strip
Courtesy of GENERAL MOTORS CORP.

2. Starting at one side, carefully press the sealing strip (1) down on the pinch weld flange (2) ensuring that

the strip is fully seated.

SEALING STRIP REPLACEMENT - REAR DOOR WINDOW BELT OUTER

Removal Procedure

1. Lower the window to the full down position.

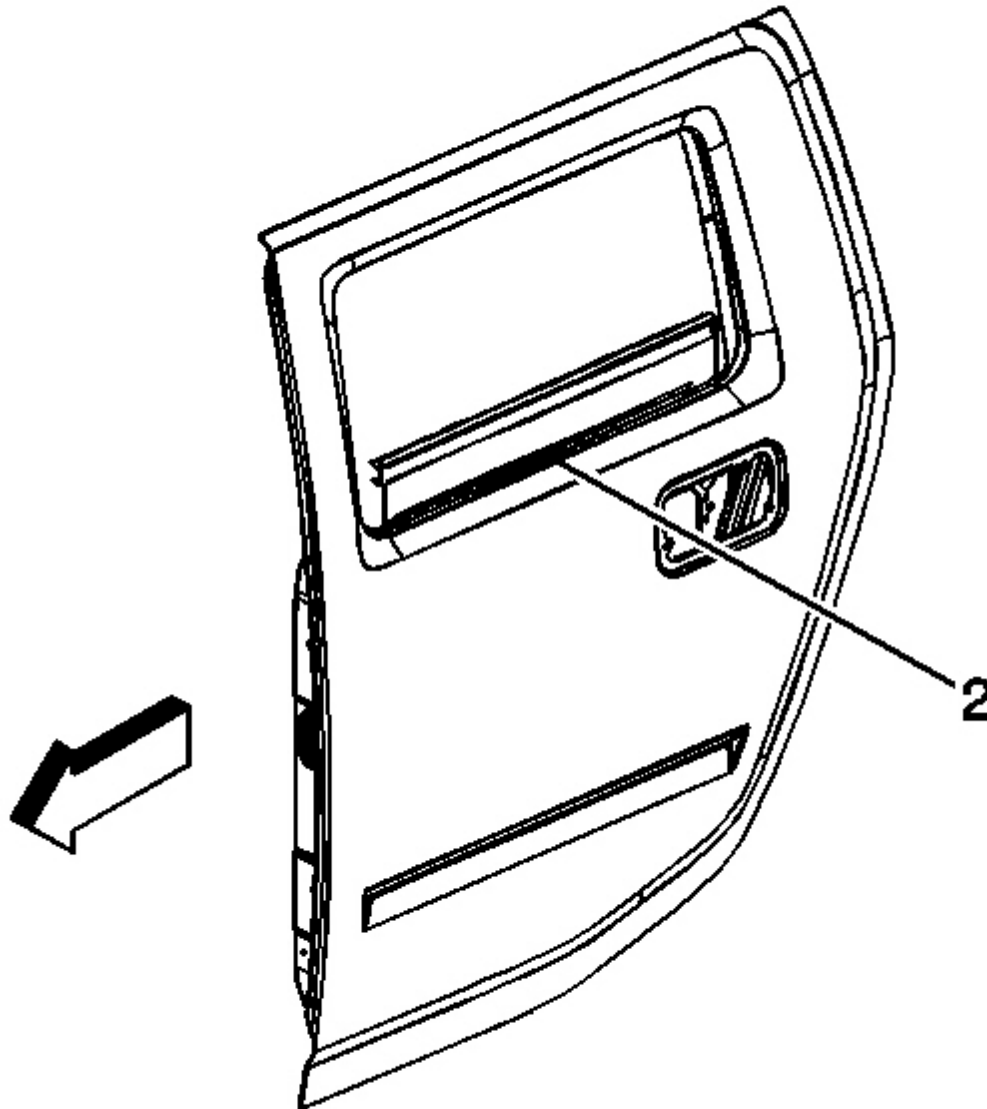

Fig. 117: Rear Door Window Sealing Strip
Courtesy of GENERAL MOTORS CORP.

2. Starting at one side, carefully remove the sealing strip by lifting the strip off of the pinch-weld flange (2).

Installation Procedure

1. Lower the window to the full down position.

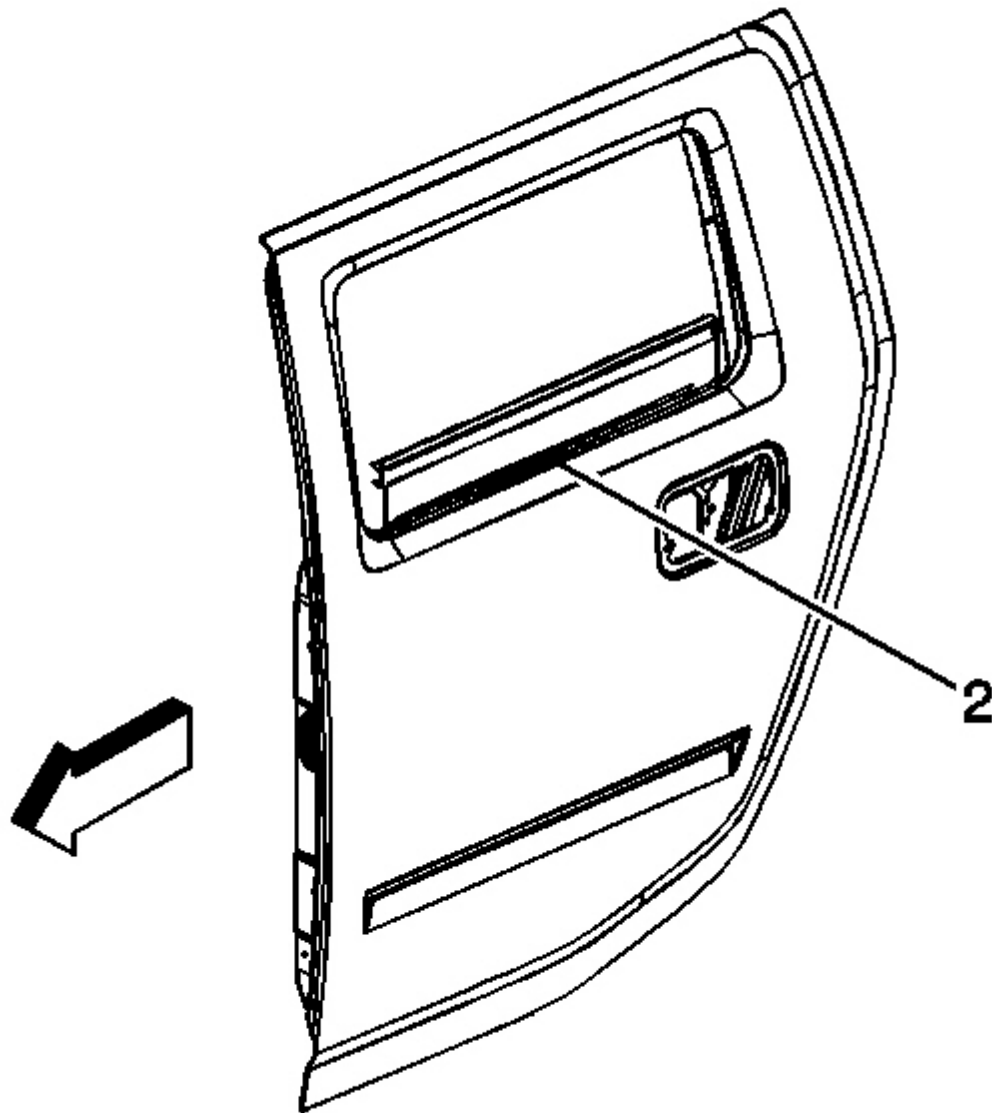

Fig. 118: Rear Door Window Sealing Strip
Courtesy of GENERAL MOTORS CORP.

2. Starting at one side, carefully press the sealing strip down on the pinch-weld flange (2) ensuring that the strip is fully seated.
3. Raise the window and inspect for proper fit.

SEALING STRIP REPLACEMENT - REAR DOOR FRONT AUXILIARY

Removal Procedure

1. Open the door.

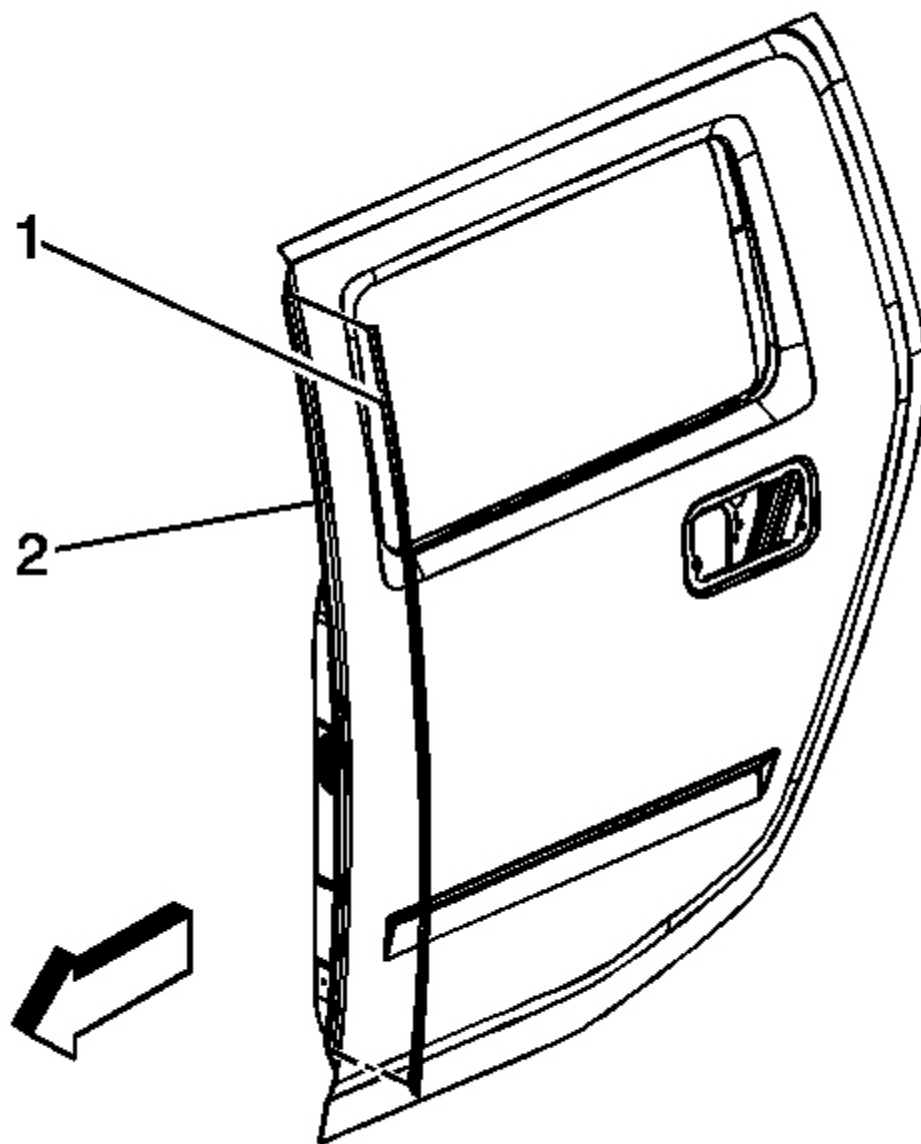

Fig. 119: Rear Door Weatherstrip

Courtesy of GENERAL MOTORS CORP.

2. Remove the weatherstrip (2) by pulling the weatherstrip off of the pinch-weld flange (1).

Installation Procedure

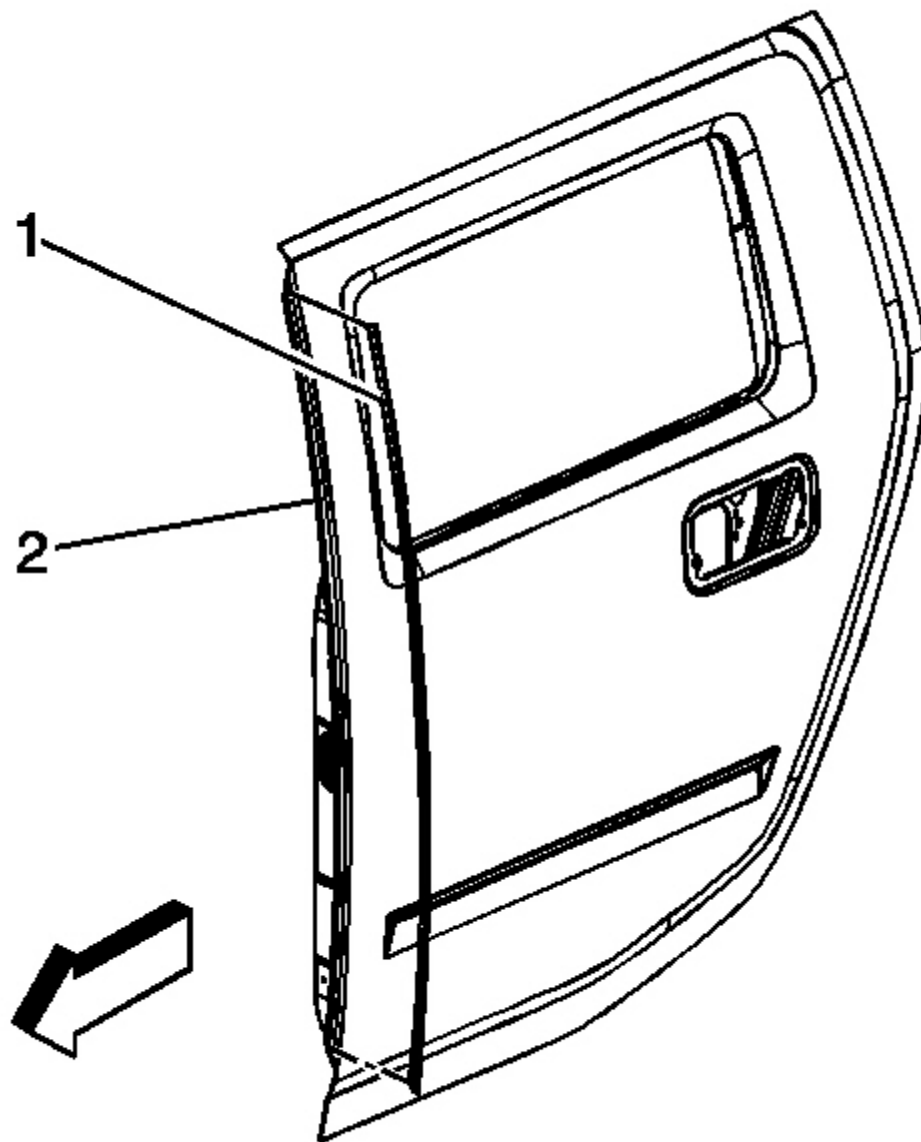

Fig. 120: Rear Door Weatherstrip

Courtesy of GENERAL MOTORS CORP.

1. Starting at the center of the pinch-weld flange, install the weatherstrip (2) to the flange (1) and work up the top and bottom towards the ends of the weatherstrip, being careful not to stretch the weatherstrip during installation.
2. Close the door.

WEATHERSTRIP REPLACEMENT - FRONT DOOR

Removal Procedure

1. Open the door.

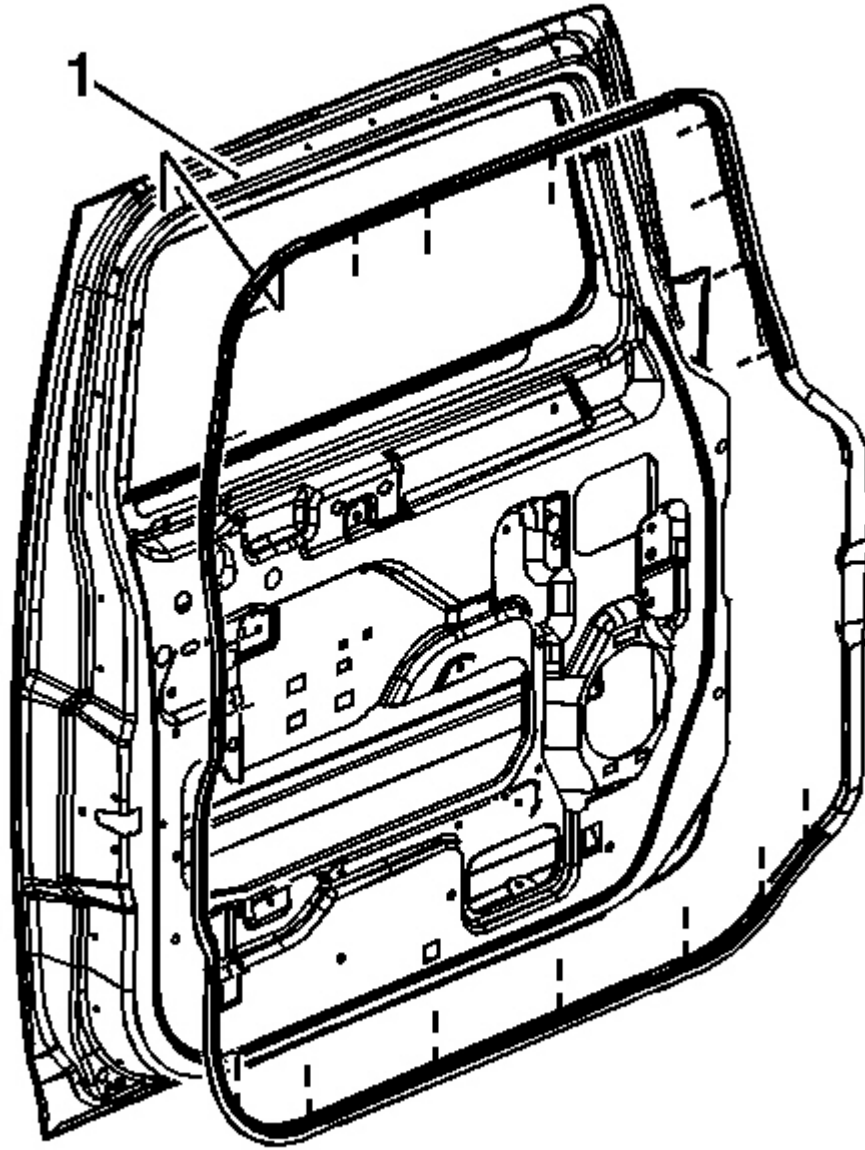

Fig. 121: Front Door Weatherstrip
Courtesy of GENERAL MOTORS CORP.

2. Using a flat-bladed tool, remove the weatherstrip by releasing the 23 retainers located on the weatherstrip from the locating holes (1) on the door.

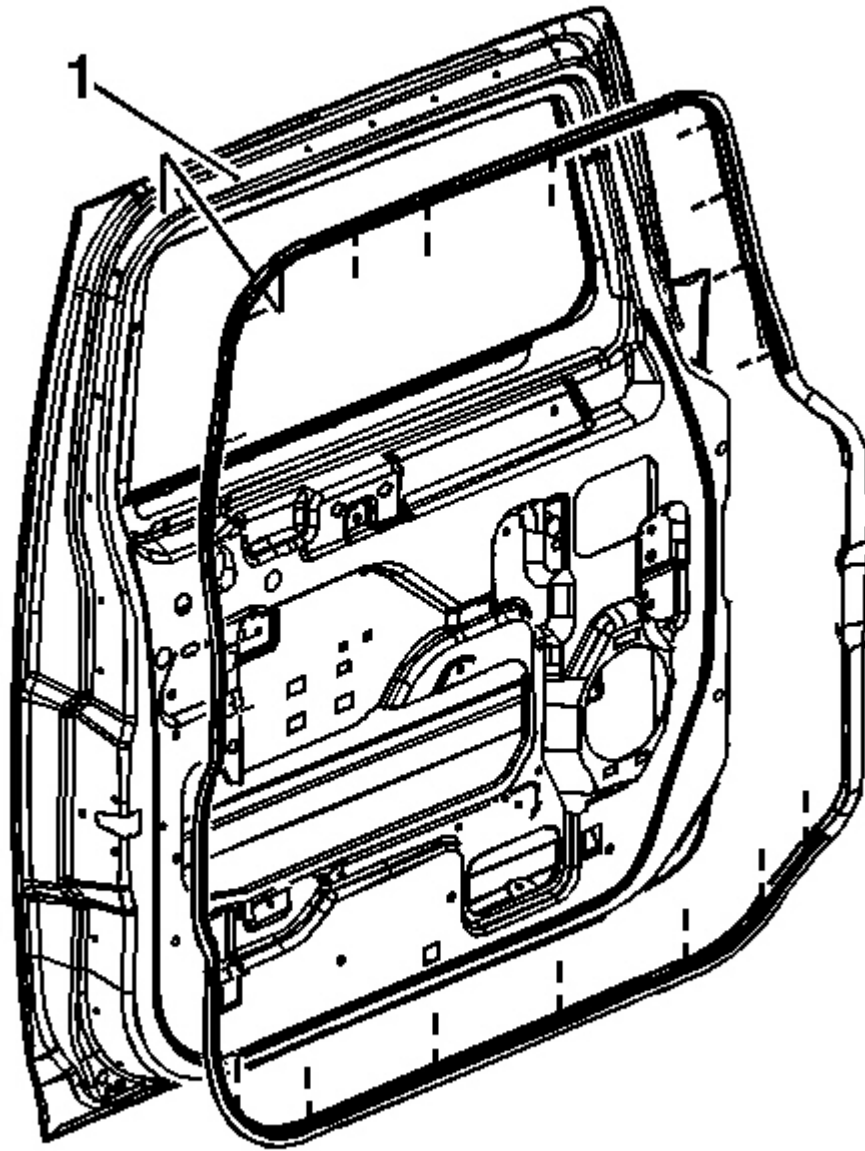

Fig. 122: Front Door Weatherstrip
Courtesy of GENERAL MOTORS CORP.

1. Install weatherstrip by securing the 23 retainers into their correct locating holes (1) on the door.
2. Close the door.

WEATHERSTRIP REPLACEMENT - FRONT DOOR WINDOW

Removal Procedure

1. Open the door.
2. Lower window to the full down position.
3. Remove the door trim panel. Refer to **Trim Panel Replacement - Side Front Door** .

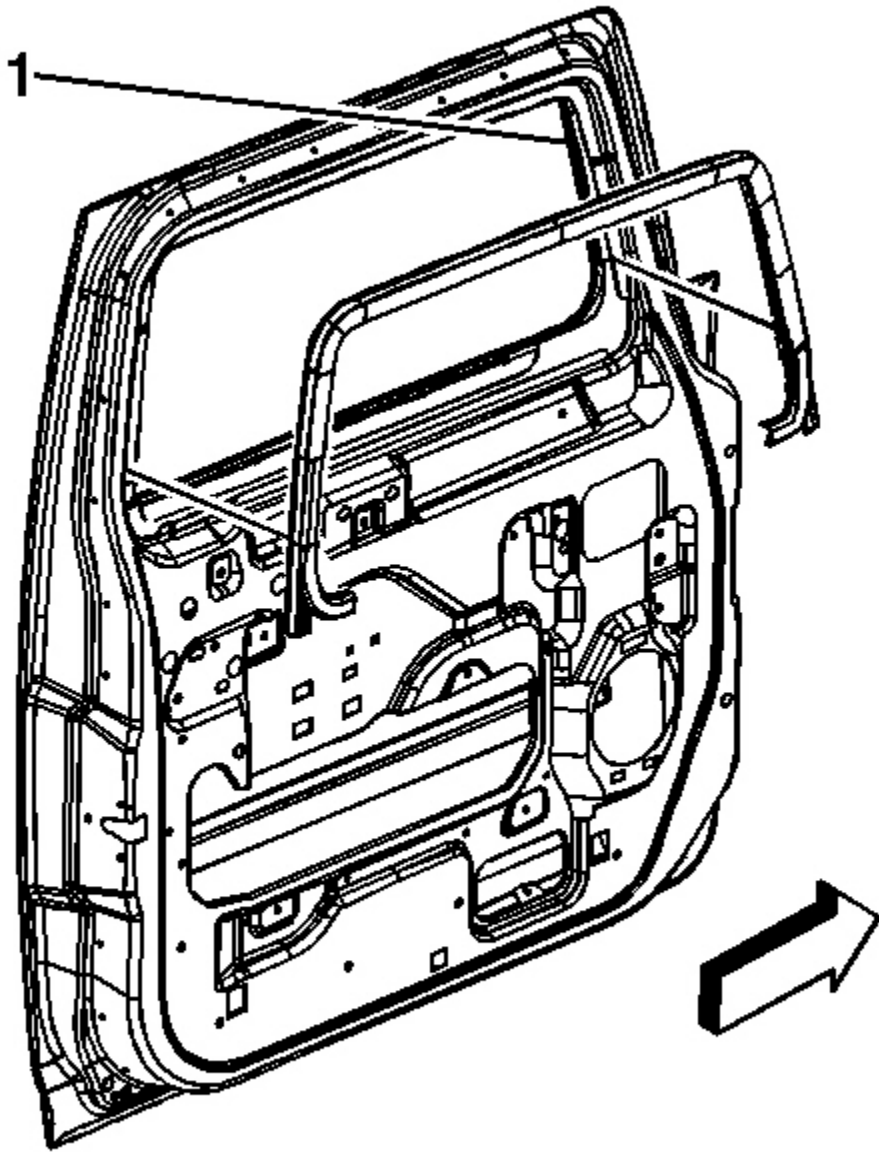

Fig. 123: Front Door Window Weatherstrip
Courtesy of GENERAL MOTORS CORP.

4. Starting at one side, remove the weatherstrip by pulling the weatherstrip off the flange in the door window frame (1).

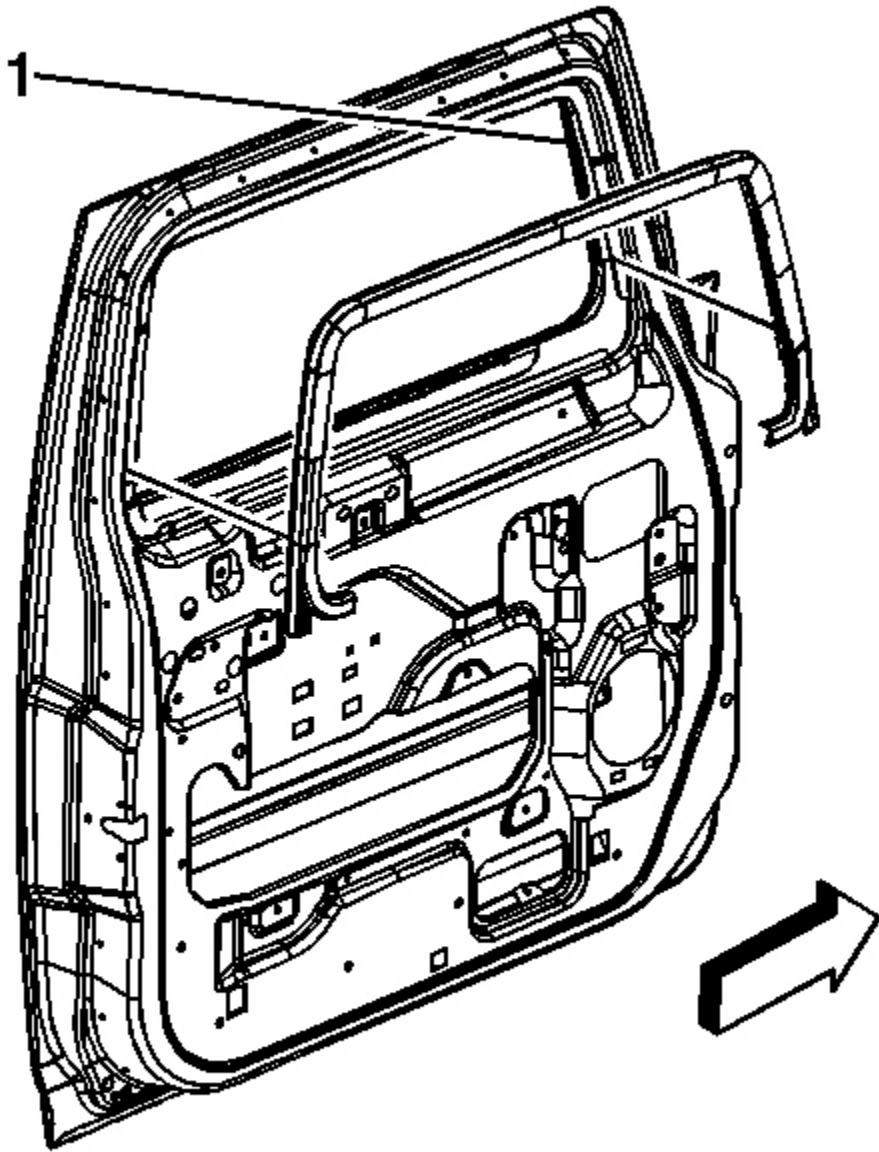

Fig. 124: Front Door Window Weatherstrip
Courtesy of GENERAL MOTORS CORP.

1. Install weatherstrip down onto the flange in the door frame (1), ensuring that it is fully seated.
2. Install the door trim panel. Refer to **Trim Panel Replacement - Side Front Door** .
3. Raise the window and inspect for proper fit.

WEATHERSTRIP REPLACEMENT - REAR DOOR WINDOW

Removal Procedure

1. Position the window in the full down position.

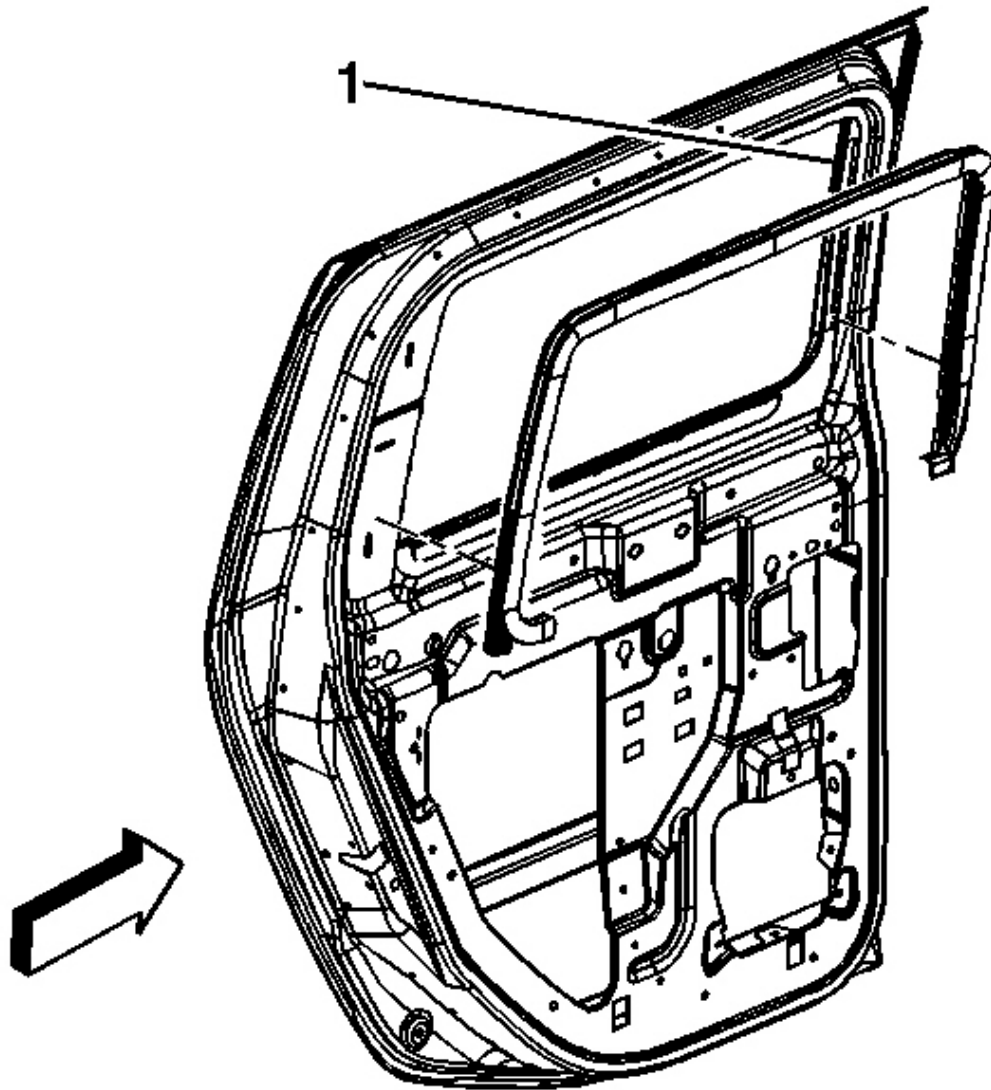

Fig. 125: Rear Door Window Weatherstrip
Courtesy of GENERAL MOTORS CORP.

2. Starting at one side, remove the weatherstrip by pulling the weatherstrip off of the flange in the door window frame (1).

Installation Procedure

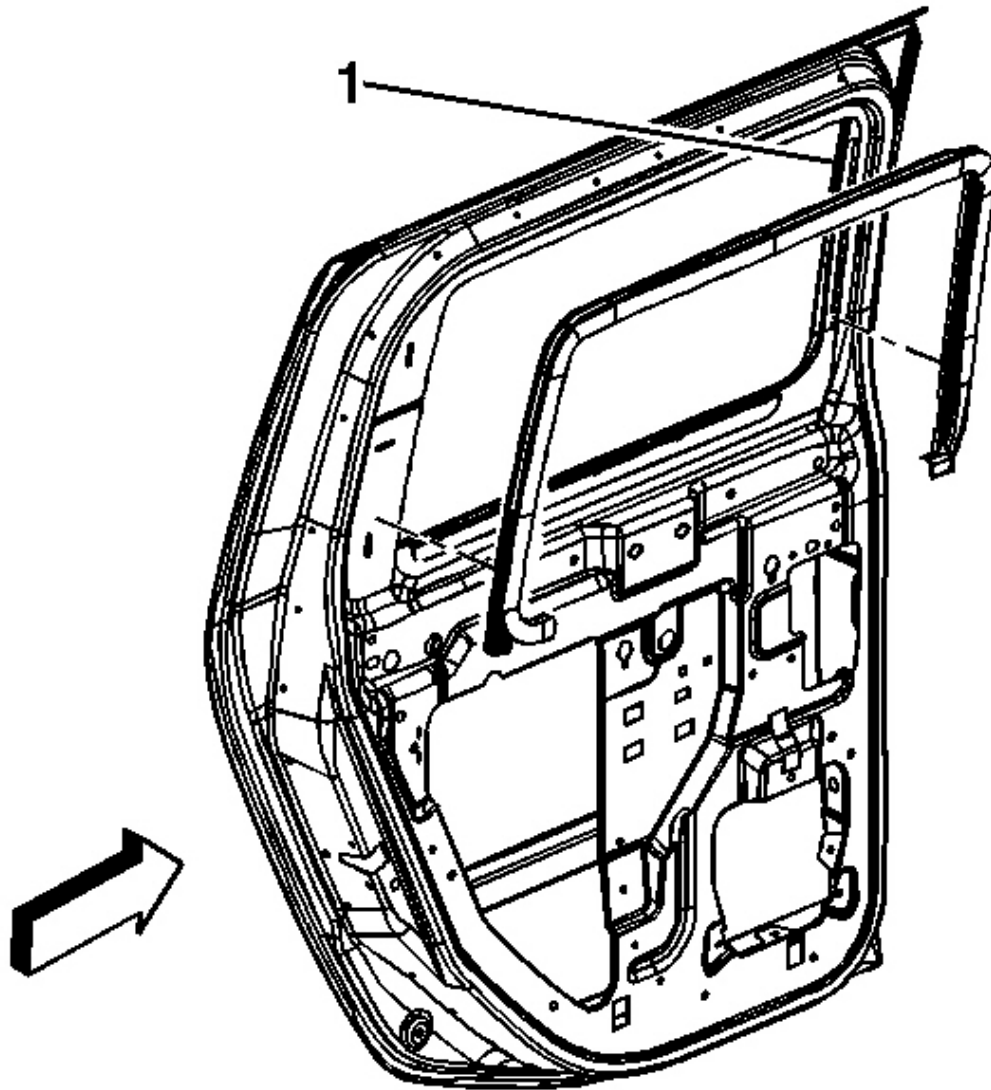

Fig. 126: Rear Door Window Weatherstrip
Courtesy of GENERAL MOTORS CORP.

1. Position the window in the full down position.

2. Install weatherstrip by pressing the weatherstrip down on the flange in the door frame (1), ensuring that it is fully seated.

WEATHERSTRIP REPLACEMENT - FRONT DOOR UPPER AUXILIARY

Removal Procedure

1. Open both front and rear side doors.

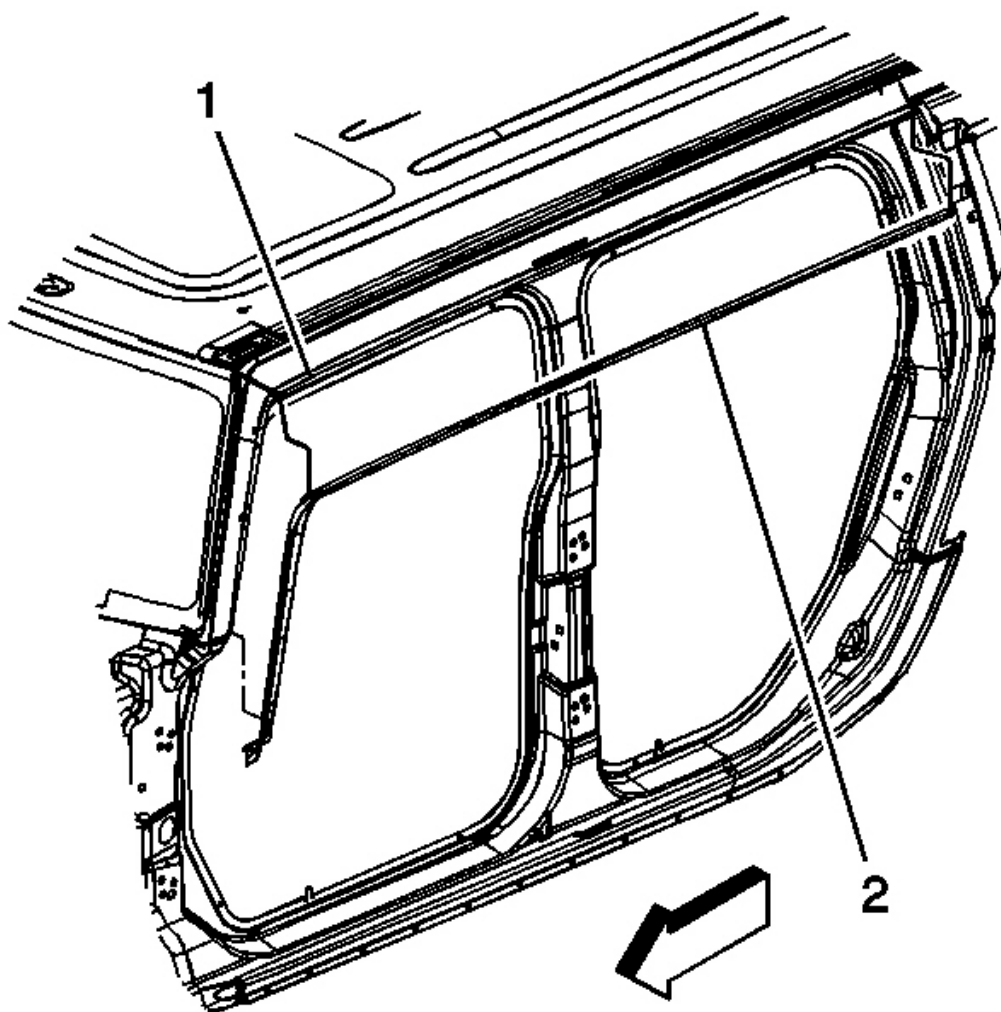

Fig. 127: Upper Door Weatherstrip (Front Door)
Courtesy of GENERAL MOTORS CORP.

2. Remove the weatherstrip (2) by pulling the weatherstrip off of the pinch-weld flange (1).

Installation Procedure

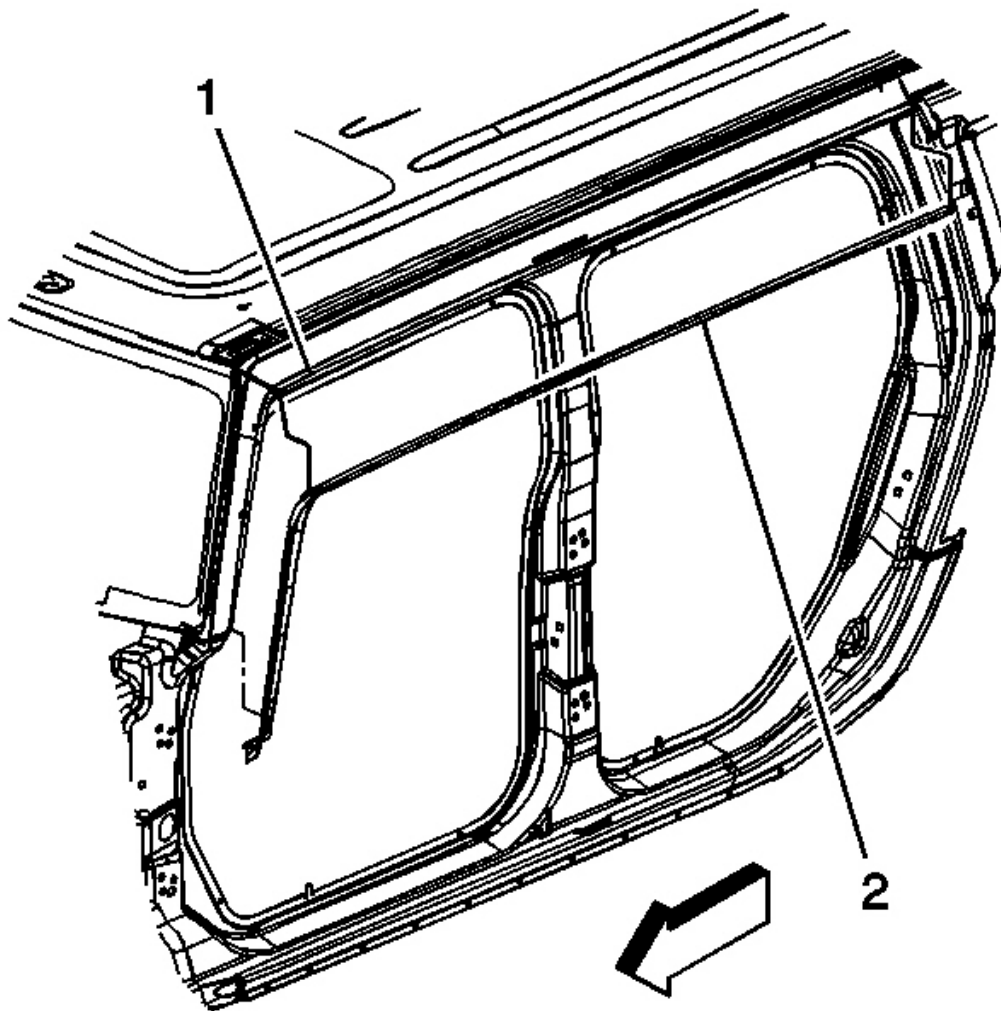

Fig. 128: Upper Door Weatherstrip (Front Door)
Courtesy of GENERAL MOTORS CORP.

1. Starting at the center of the door openings, install the weatherstrip (2) to the pinch-weld flange (1) and work across the right and left sides towards the ends of the weatherstrip, being careful not to stretch the weatherstrip during installation.
2. Close the door.

WEATHERSTRIP REPLACEMENT - REAR DOOR UPPER AUXILIARY

Removal Procedure

1. Open both front and rear side doors.

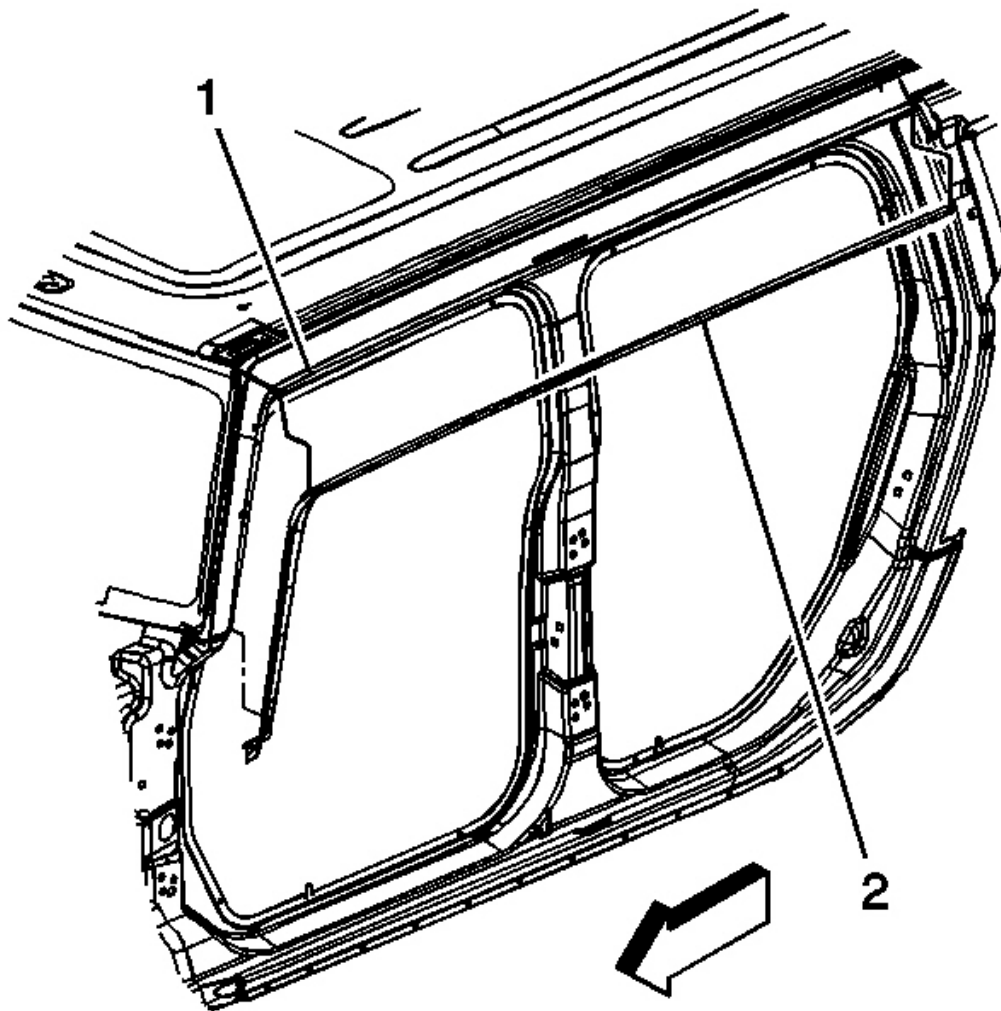

Fig. 129: Upper Door Weatherstrip (Rear Door)
Courtesy of GENERAL MOTORS CORP.

2. Remove the weatherstrip (2) by pulling the weatherstrip off of the pinch-weld flange (1).

Installation Procedure

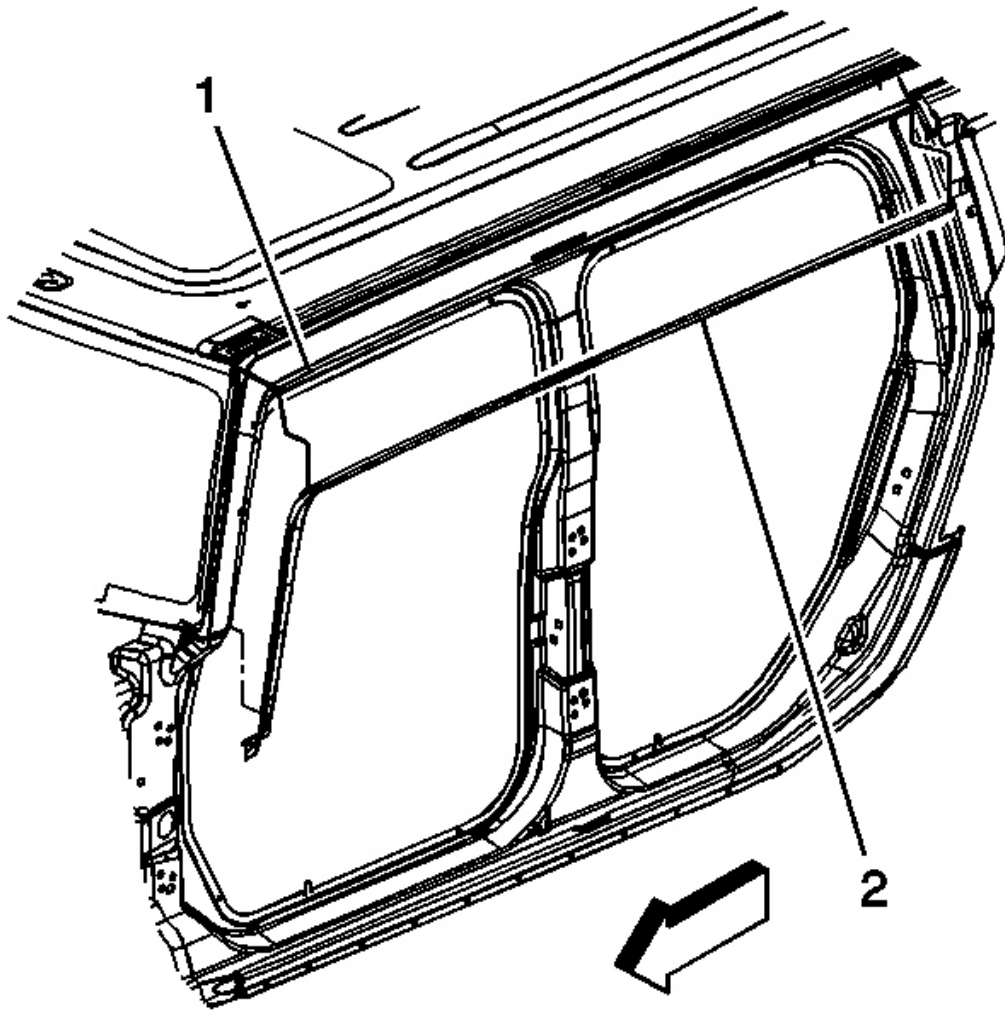

Fig. 130: Upper Door Weatherstrip (Rear Door)
Courtesy of GENERAL MOTORS CORP.

1. Starting at the center of the door openings, install the weatherstrip (2) to the pinch-weld flange (1) and work across the right and left sides towards the ends of the weatherstrip, being careful not to stretch the weatherstrip during installation.
2. Close the doors.

WEATHERSTRIP REPLACEMENT - FRONT DOOR AUXILIARY

Removal Procedure

1. Open the door.

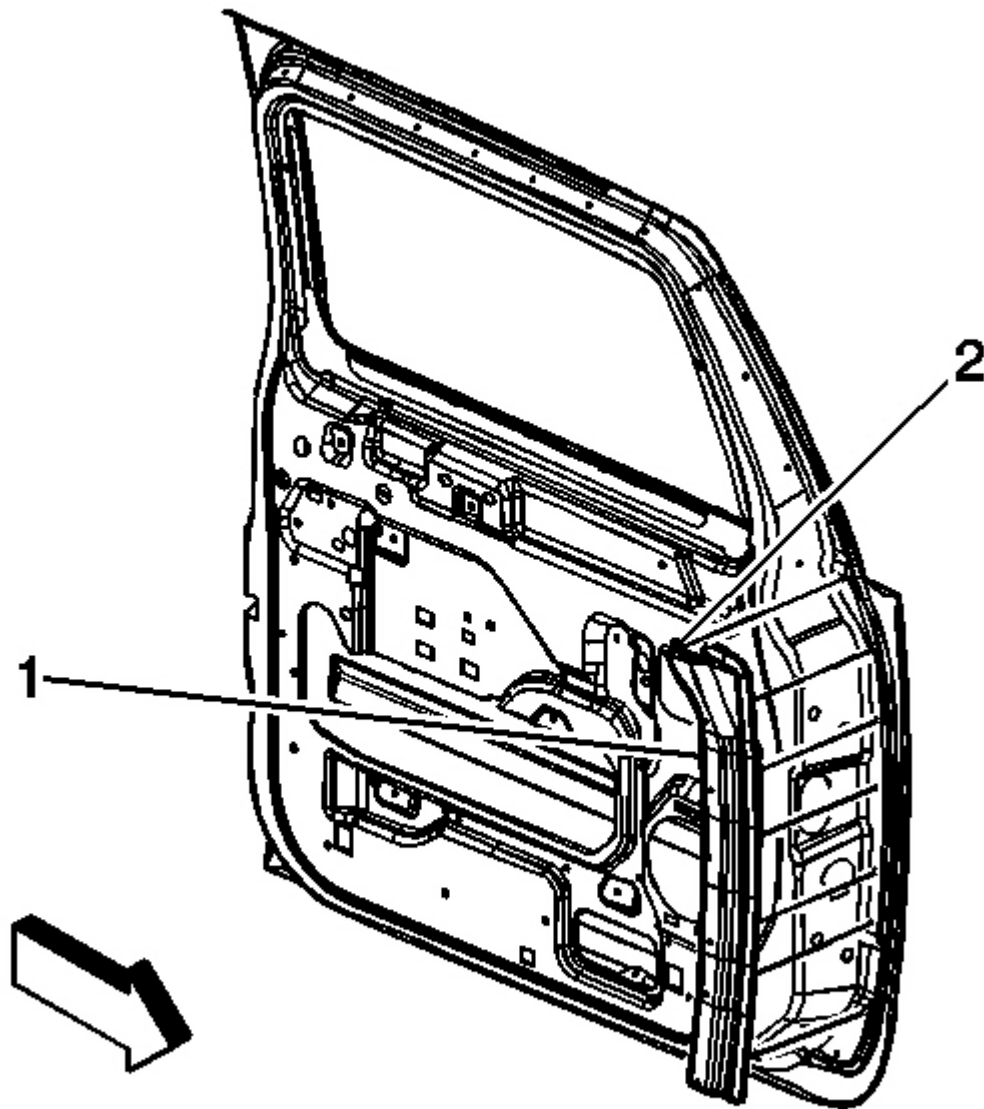

Fig. 131: Front Auxiliary Door Weatherstrip
Courtesy of GENERAL MOTORS CORP.

2. Using a flat-bladed tool, release the 7 retainers (2) securing the weatherstrip (1) to the door.
3. Remove the weatherstrip from the door.

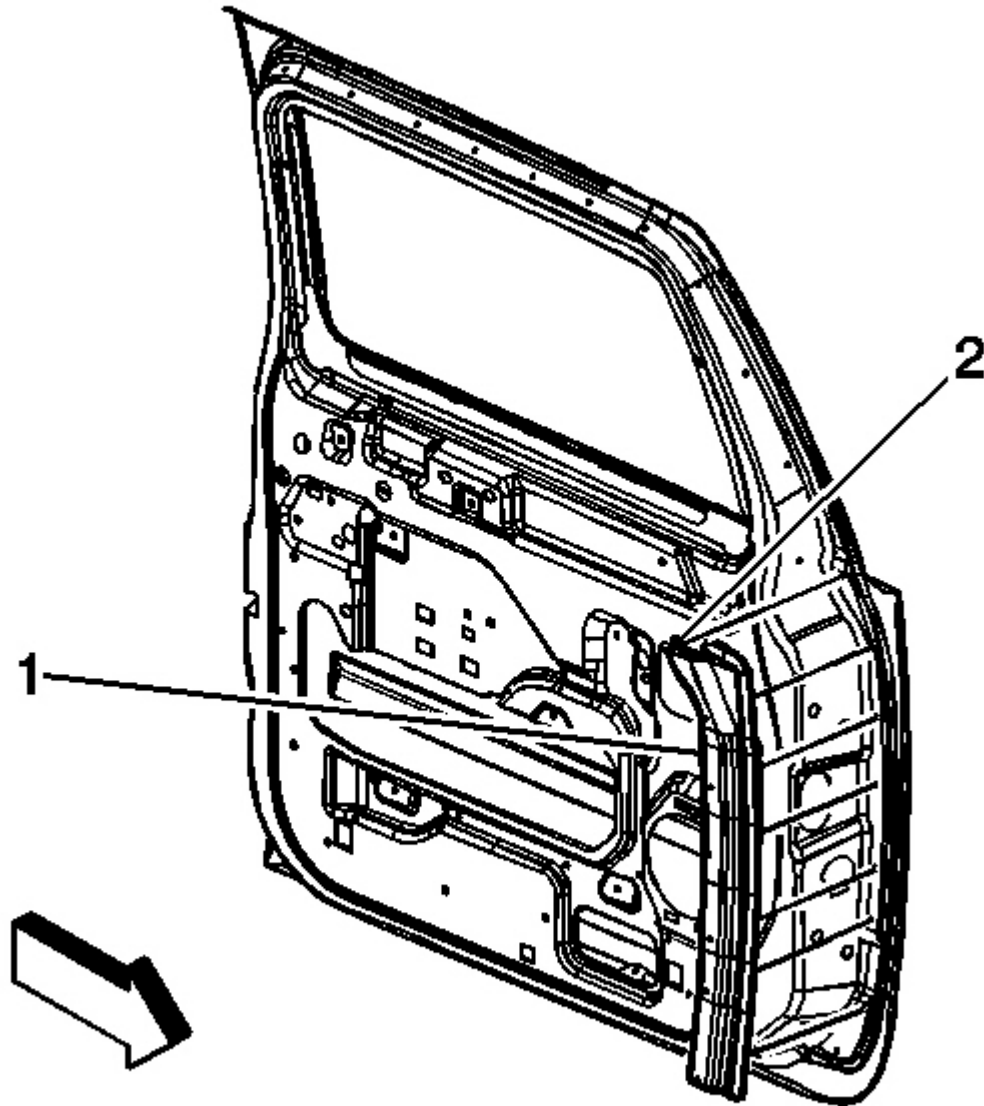

Fig. 132: Front Auxiliary Door Weatherstrip
Courtesy of GENERAL MOTORS CORP.

1. Attach the weatherstrip (1) to the door by installing the 7 retainers (2) that secure it to the door.
2. Close the door.

WEATHERSTRIP REPLACEMENT - REAR DOOR AUXILIARY

Removal Procedure

1. Open the doors.

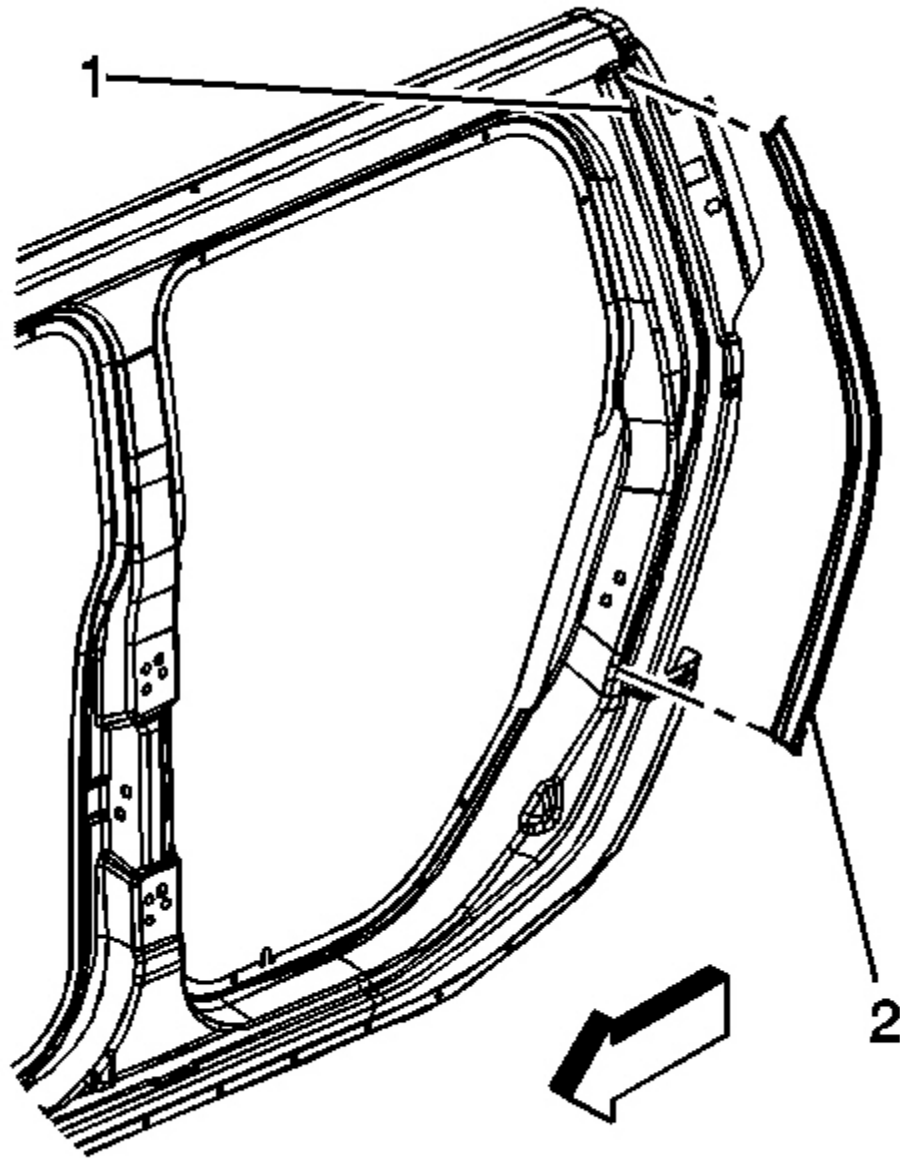

Fig. 133: Rear Auxiliary Door Weatherstrip

Courtesy of GENERAL MOTORS CORP.

2. Remove the weatherstrip (2) by pulling the weatherstrip off of the pinch-weld flange (1).

Installation Procedure

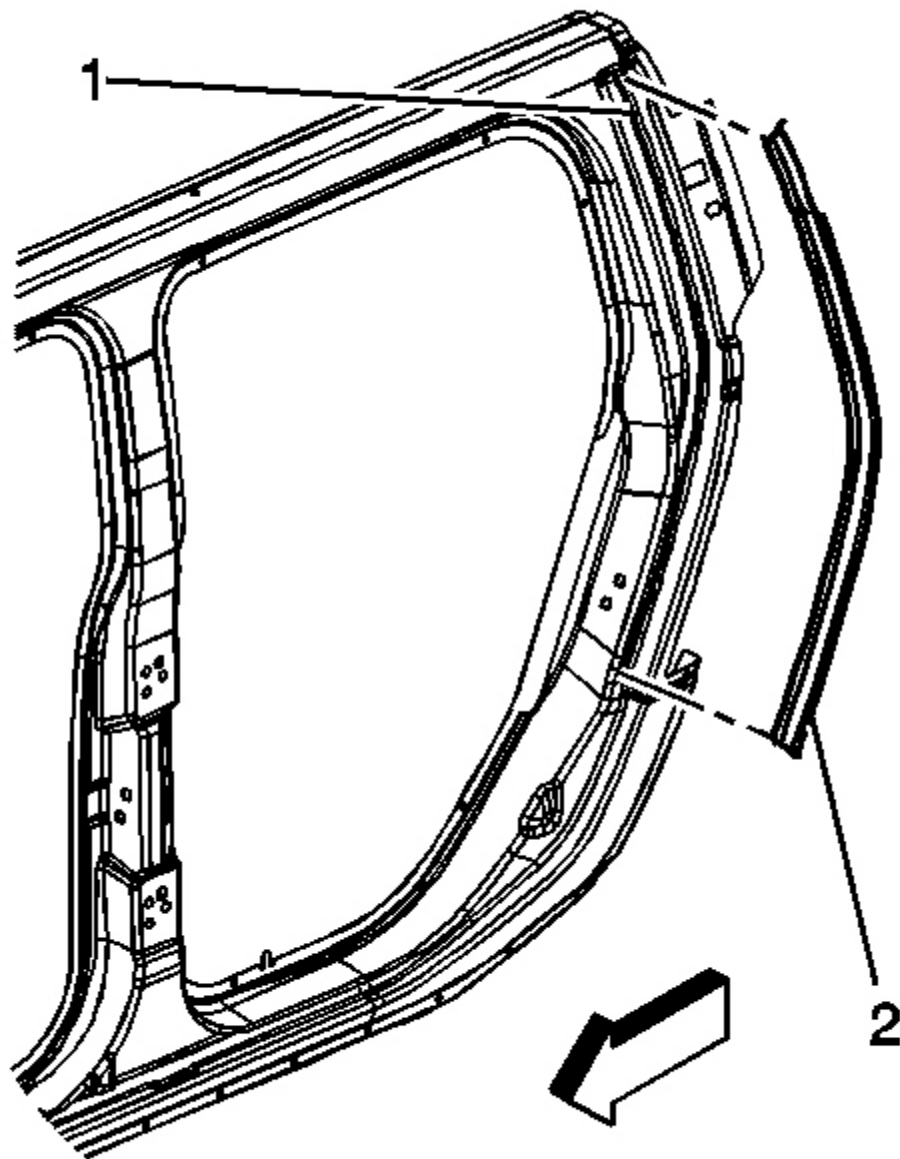

Fig. 134: Rear Auxiliary Door Weatherstrip

Courtesy of GENERAL MOTORS CORP.

1. Starting at the center of the pinch-weld flange, install the weatherstrip (2) to the flange (1) and work up the top and bottom towards the ends of the weatherstrip, being careful not to stretch the weatherstrip during installation.
2. Close the doors.

WEATHERSTRIP REPLACEMENT - REAR DOOR

Removal Procedure

1. Open the doors.

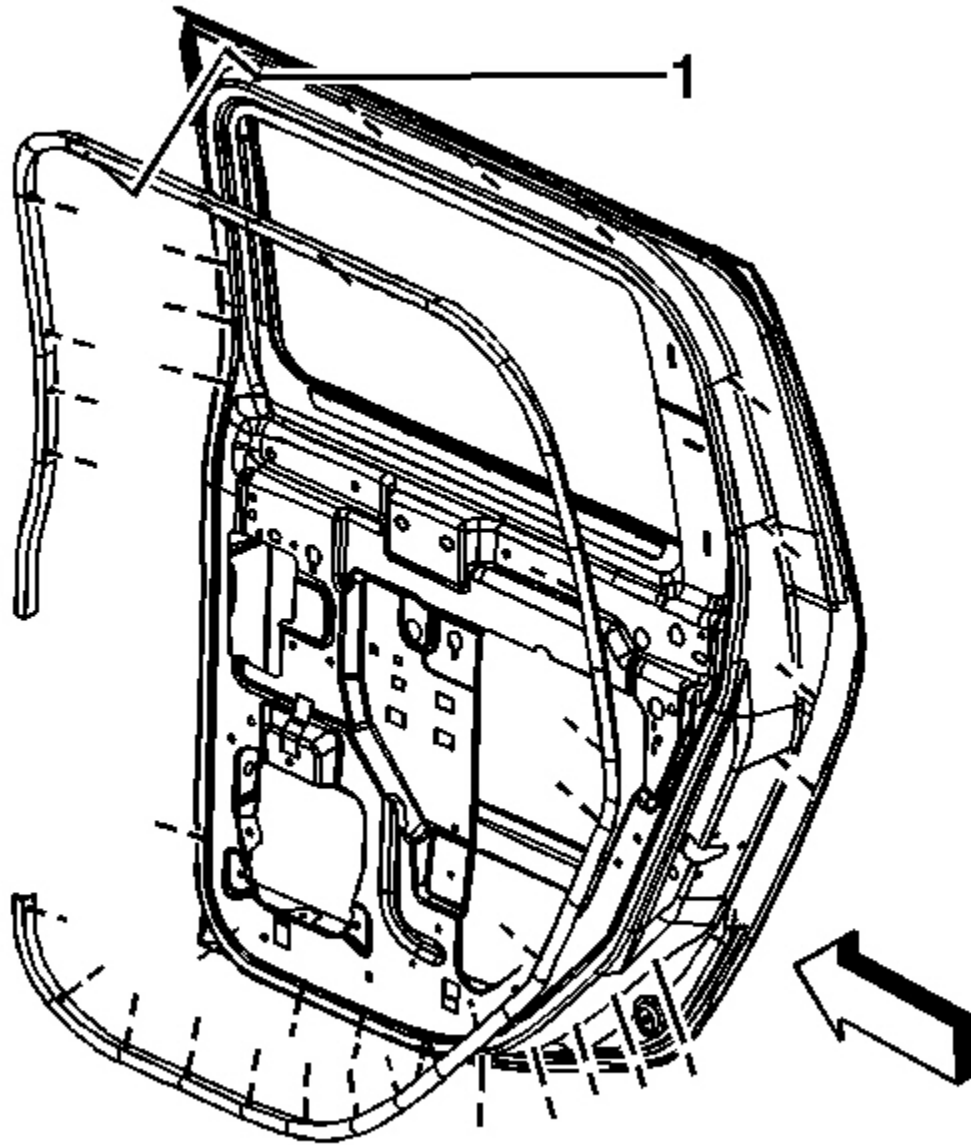

Fig. 135: Rear Door Weatherstrip
Courtesy of GENERAL MOTORS CORP.

2. Using a flat-bladed tool, remove the weatherstrip by releasing the 22 retainers located on the weatherstrip from the locating holes (1) on the door.

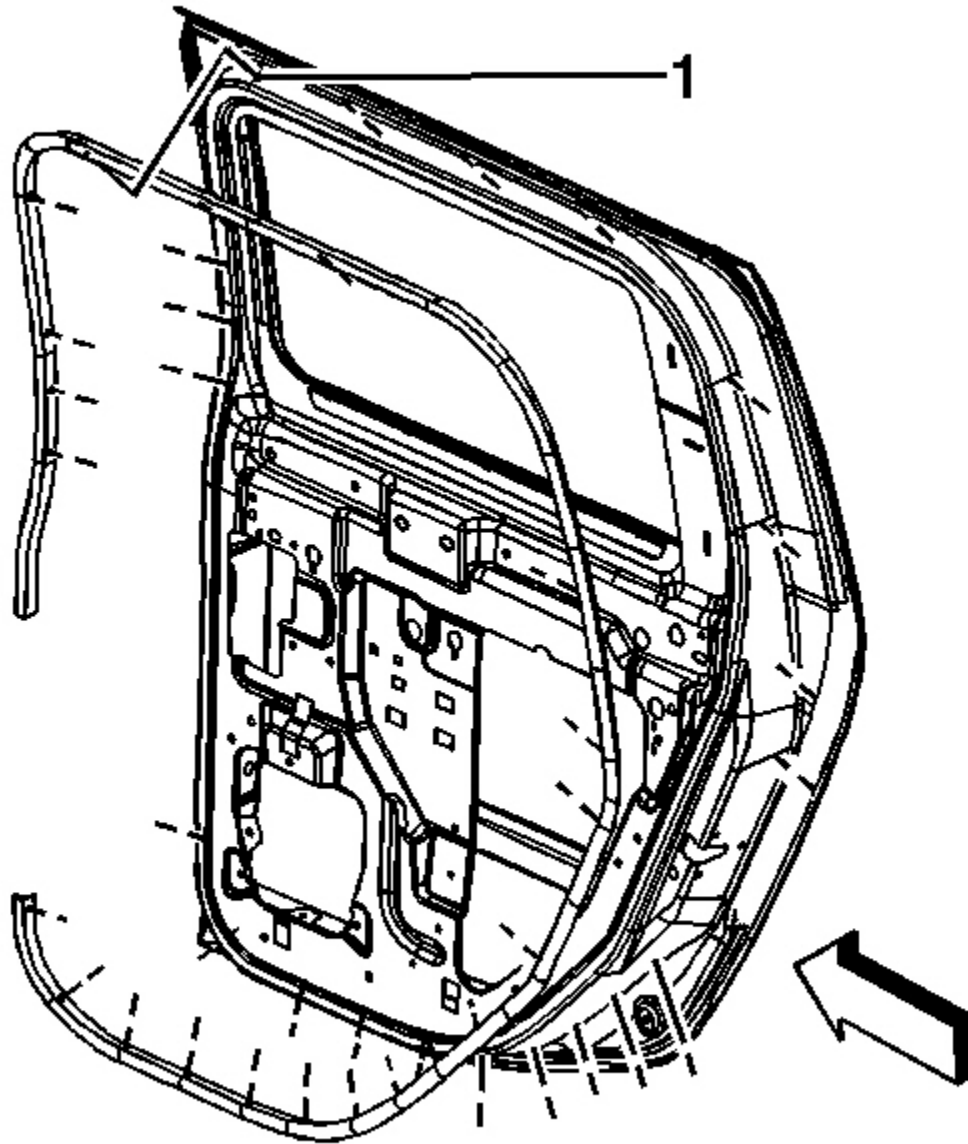

Fig. 136: Rear Door Weatherstrip
Courtesy of GENERAL MOTORS CORP.

1. Install weatherstrip by securing the 22 retainers into their correct locating holes (1) on the door.
2. Close the doors.

Removal Procedure

1. Open the door.

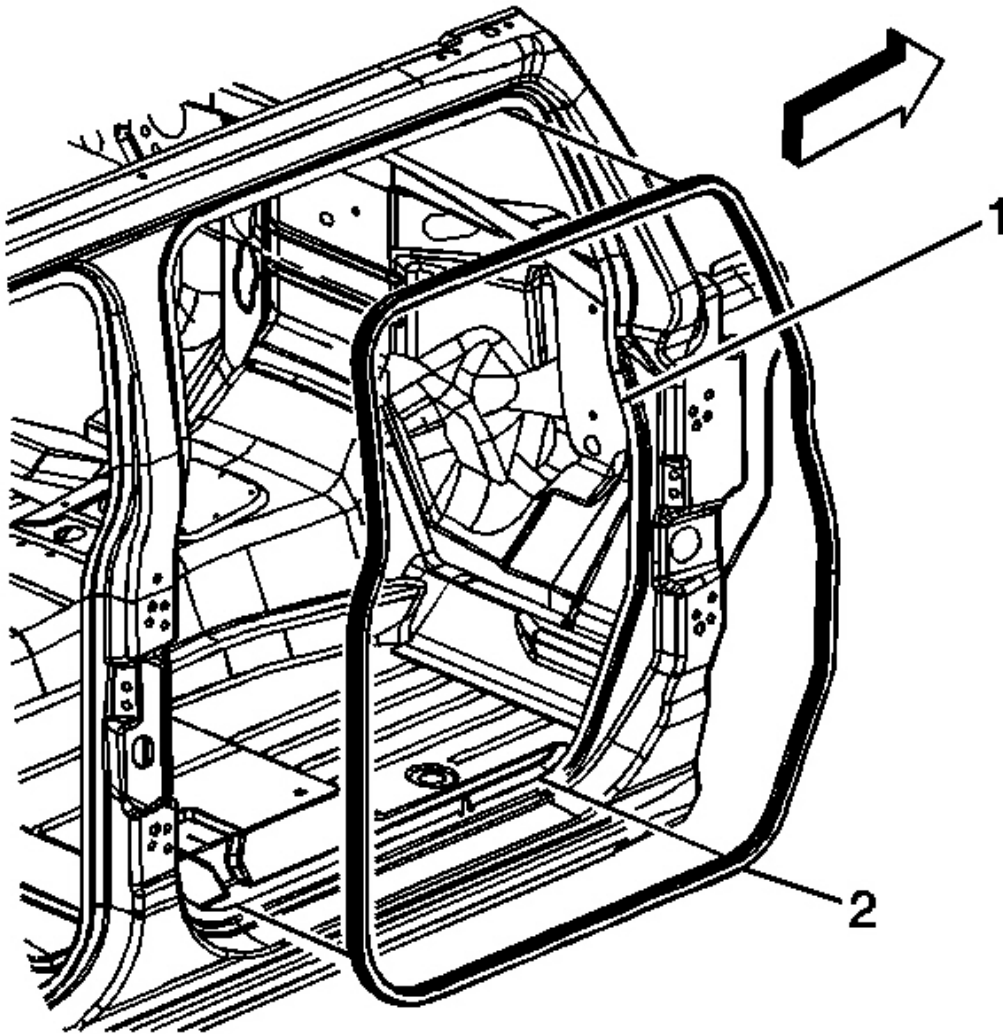

Fig. 137: Front Door Opening Weatherstrip
Courtesy of GENERAL MOTORS CORP.

2. Remove the weatherstrip (2) by pulling the weatherstrip off of the door opening pinch-weld flange (1).

Installation Procedure

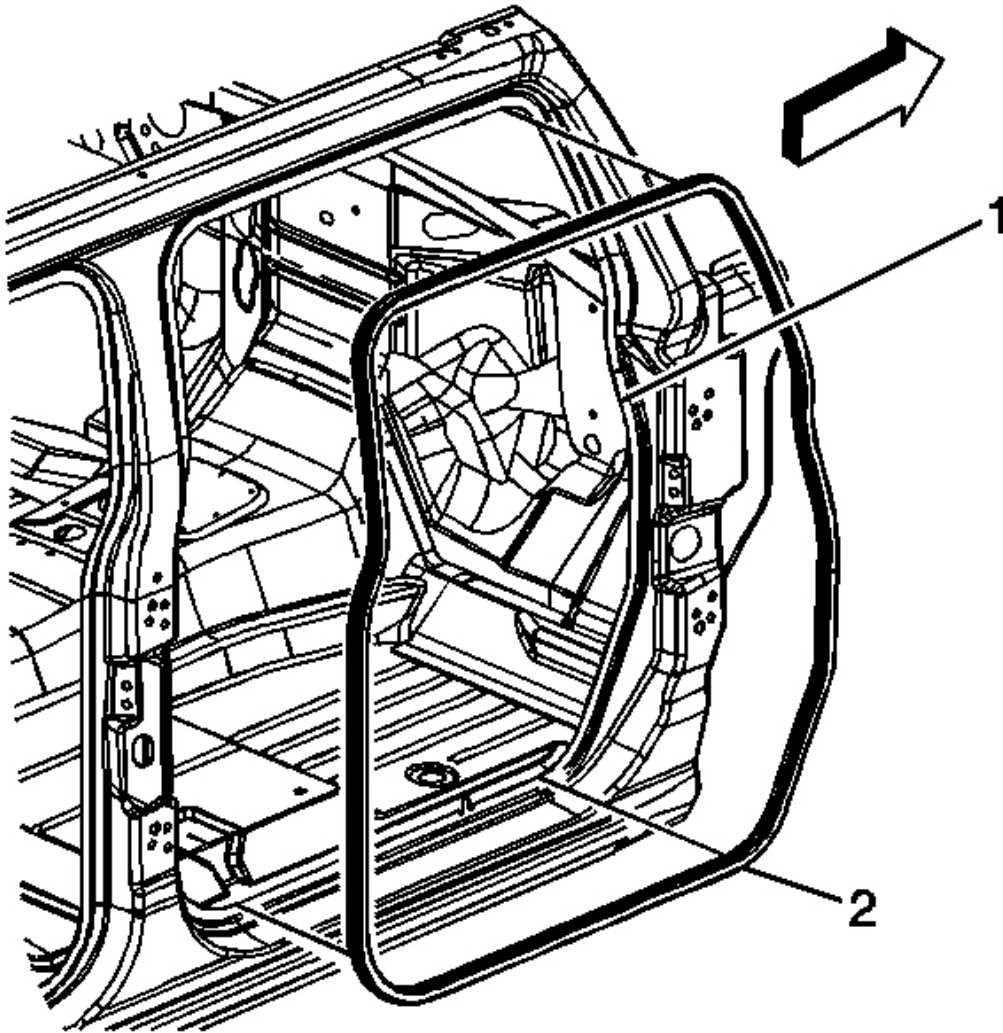

Fig. 138: Front Door Opening Weatherstrip
Courtesy of GENERAL MOTORS CORP.

1. Starting at the top center of the door opening, install the weatherstrip (2) to the pinch-weld flange (1) and work down the right and left sides towards the bottom center, being careful not to stretch the weatherstrip during installation.
2. Use a rubber mallet to ensure proper seating of the weatherstrip on the pinch-weld flange.
3. Close the door.

Removal Procedure

1. Open the door.

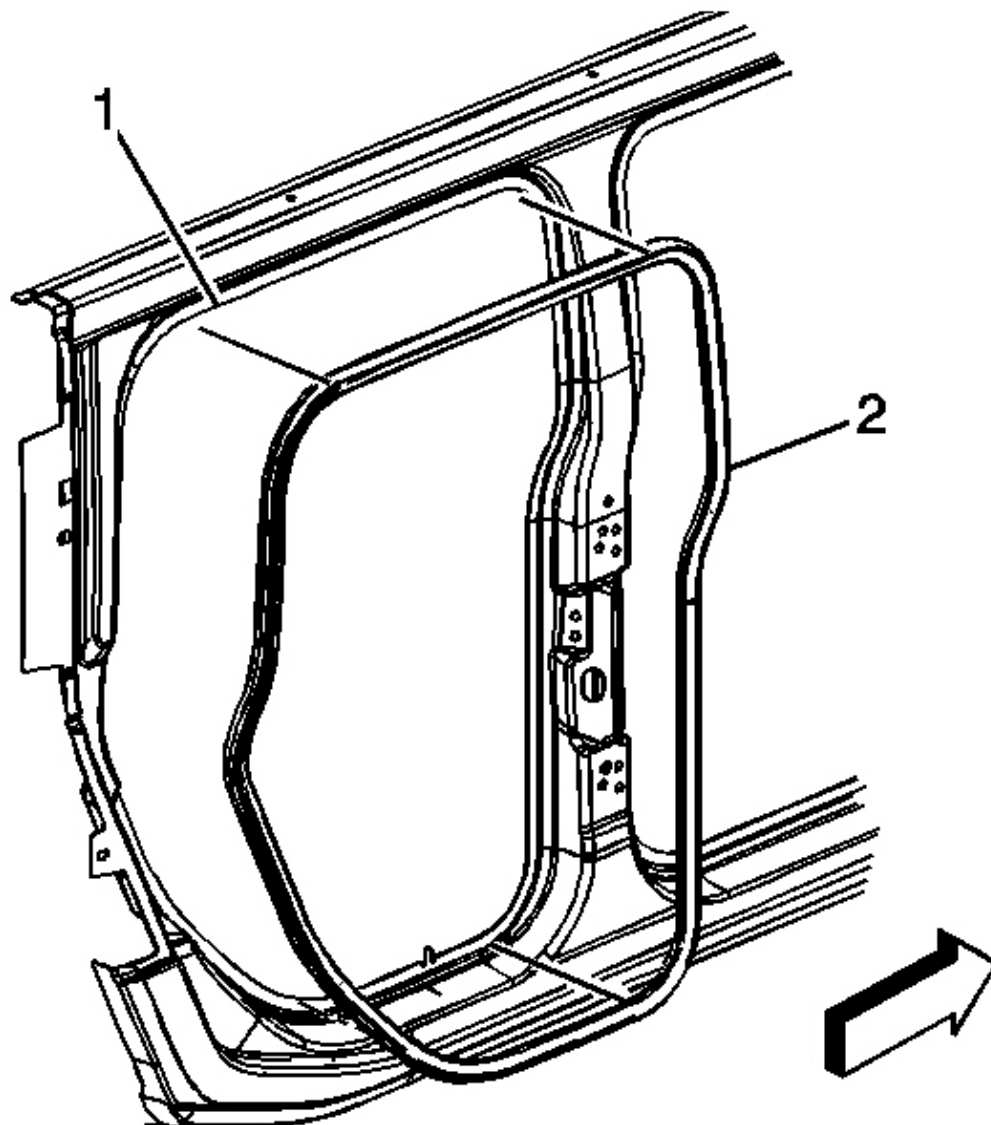

Fig. 139: Rear Door Opening Weatherstrip
Courtesy of GENERAL MOTORS CORP.

2. Remove the weatherstrip (2) by pulling the weatherstrip off of the door opening pinch-weld flange (1).

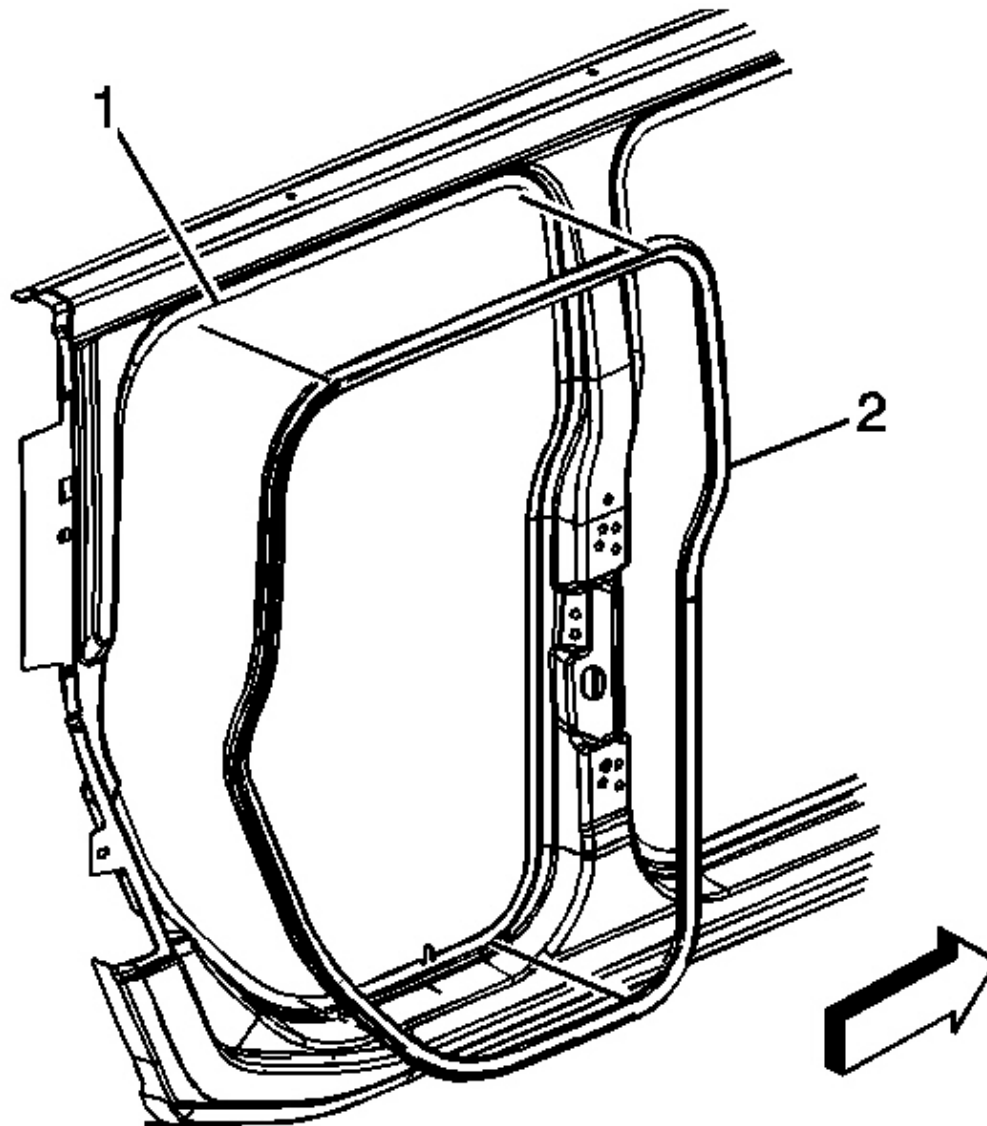

Fig. 140: Rear Door Opening Weatherstrip
Courtesy of GENERAL MOTORS CORP.

1. Starting at the top center of the door opening, install the weatherstrip (2) to the pinch-weld flange (1) and work down the right and left sides towards the bottom center, being careful not to stretch the weatherstrip during installation.

2. Use a rubber mallet to ensure proper seating of the weatherstrip on the pinch-weld flange.
3. Close the door.

MIRROR REPLACEMENT

Removal Procedure

1. Remove the door trim panel. Refer to Trim Panel Replacement - Side Front Door .
2. Remove the water deflector. Refer to Water Deflector Replacement - Front Door .

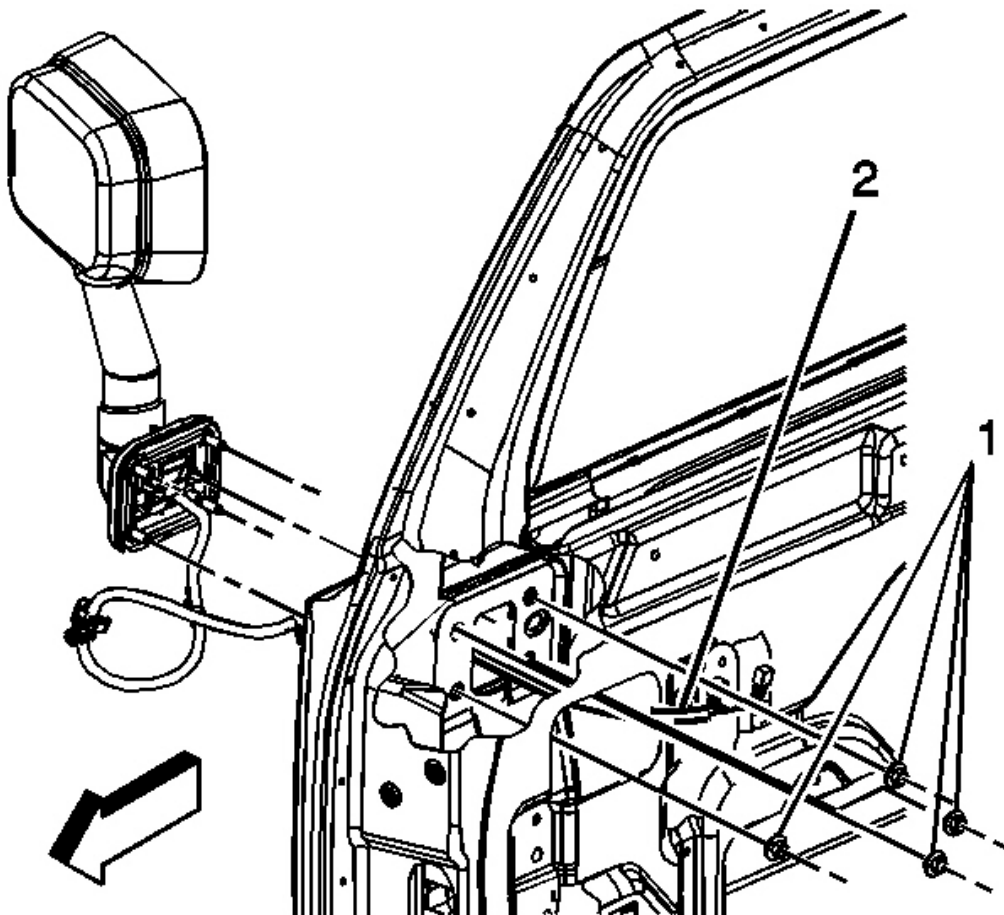

Fig. 141: Front Door Mirror
Courtesy of GENERAL MOTORS CORP.

3. Disconnect the mirror electrical connector (2).

4. Remove the fasteners (1) retaining the mirror to the door.
5. Remove the mirror from the vehicle.

Installation Procedure

1. Place the mirror into position on door.

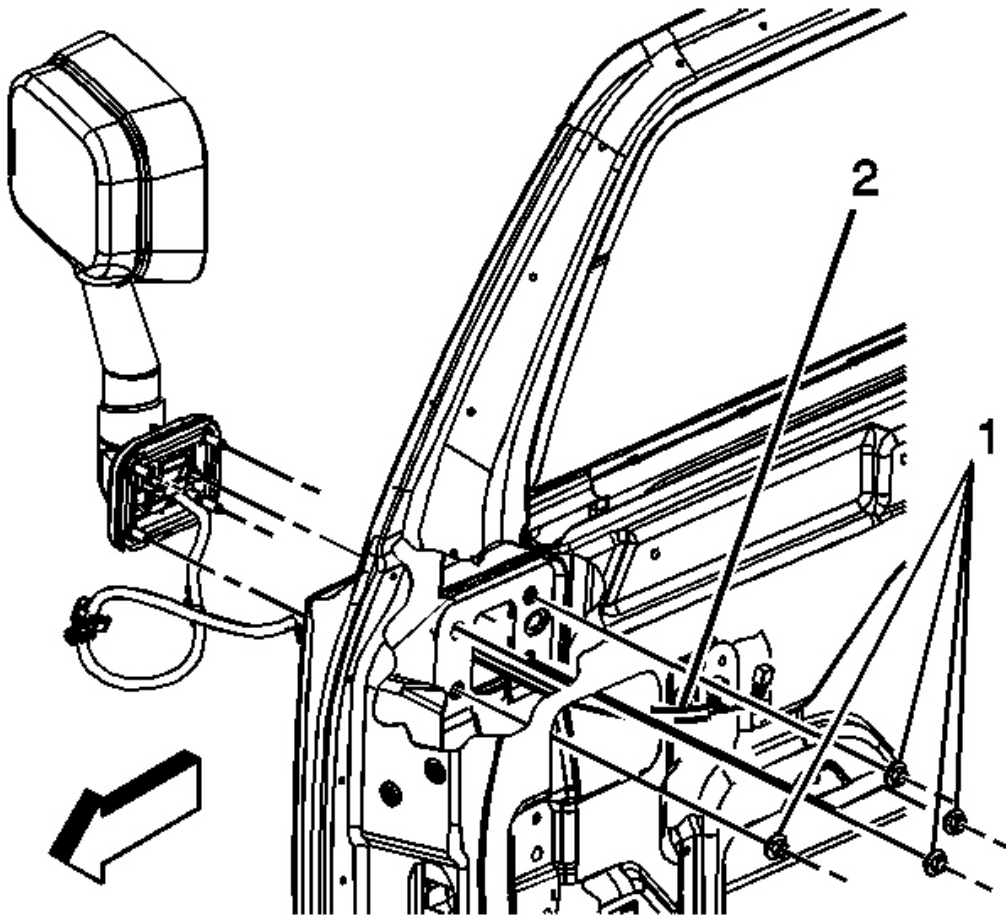

Fig. 142: Front Door Mirror
Courtesy of GENERAL MOTORS CORP.

NOTE: Refer to Fastener Notice in Cautions and Notices.

2. Install the fasteners (1) retaining the mirror to the door.

Tighten: Tighten the fasteners to 25 N.m (18 lb ft).

3. Connect the mirror electrical connector.
4. Install the water deflector. Refer to **Water Deflector Replacement - Front Door** .
5. Install the door trim panel. Refer to **Trim Panel Replacement - Side Front Door** .

DESCRIPTION AND OPERATION

POWER WINDOWS DESCRIPTION AND OPERATION

Power Window System Components

The power window system consists of the following components:

- Driver Door Module (DDM)
- Passenger Door Module (PDM)
- Body Control Module (BCM)
- RR power window switch
- Window up and window down relays in each of the rear passenger window switches
- Window lockout switch
- Reversible power window motors in each of the doors (circuit breaker protected)
- LT DOOR CB 25A (System power for left windows)
- RT DOOR CB 25A (System power for right windows)

Power Window System Controls

The power window system will operate anytime the Retained Accessory Power (RAP) system is active or when the ignition switch is in the ACCY or ON position.

The DDM contains four power window switches which are integral components. Closing any of the normally open, rocker type switches provides the DDM with a request for power window operation. The switches for the two front windows have three positions UP, Down and Express Down, while the switches for the rear windows have only two positions, UP and Down. Each of these switches and their positions is a direct input into the DDM. Upon receiving a request for power window operation, the DDM, transmits a Class 2 message indicating the switch and it's changed position.

The PDM contains a single power window switch that is an integral component. Closing of this normally open, rocker switch provides the PDM with a request for the front passenger power window operation. The switch for the front passenger window has two positions Up and Down. Each of these switch positions is a direct input to the PDM.

The two rear passenger doors have there own switches. Each of the switches contain a power window up and down relay. A switch activation alone can control the up and down functions of the rear windows. However the BCM, upon receiving a Class 2 message from the DDM, can control the set of relays which will activate the

rear window motors.

Power Window Motor Operation

A permanent magnet motor operates each of the power side windows. Each motor raises or lowers the glass when the motor receives voltage. The direction the motor turns depends on the polarity of the supply voltage. The power window switches control the polarity of the supply voltage. A built-in circuit breaker protects each motor. The circuit breaker opens when the switch is depressed for an extended period of time under the following conditions:

- The window has an obstruction.
- The window is fully open or fully closed.

The circuit breaker will reset automatically as the circuit breaker cools.

Driver Power Window Operation

The switch for the driver power window has three positions UP, Down and Express Down and its position is a direct input into the DDM. Upon receiving a request for power window operation (switch activation), the DDM supplies voltage to the power window motor left front up or down circuit and grounds the opposite and the power window motor runs to move the window up or down.

Front Passenger Power Window Operation

The switch for the front passenger power window has two positions UP and Down, and its position is a direct input into the PDM. Upon receiving a request for power window operation (switch activation), the PDM supplies voltage to the power window motor right front up or down circuit and grounds the opposite and the power window motor runs to drive the window up or down.

The front passenger power window can also be controlled from the power window master switch. The power window master switch for the front passenger power window has three positions UP, Down and Express Down and its position is a direct input into the DDM. Upon receiving a request for front passenger power window operation (switch activation), the DDM transmits a Class 2 message indicating the changed switch position. When the PDM receives this message, the PDM supplies voltage to the power window motor right front up or down circuit and grounds the opposite and the power window motor runs to move the window up or down.

Rear Passenger Power Window Operation

The passenger power window switches incorporate window up and down relays. The supply side of all the window up and down relays receive voltage through the battery voltage supply circuit and the LT DOOR or RT DOOR circuit breakers respectively. The normally closed contacts of each relay is connected to ground. The load side of each of the relays are connected to either side of the power window motor through the power window up and down circuits. The relay coil feed circuits are connected to the BCM through the power window lockout control circuit and the relay control circuits are connected to the power window switches and to the BCM.

If a rear power window switch is placed in the down position, the down relay would energize and allow battery

voltage to the power window motor through the power window motor down circuit. Since the opposite side of the motor is connected to the normally closed contacts of the up relay to ground through the power window motor up circuit, the window moves down. If a rear power window switch is placed in the up position, the up relay would energize and allow battery voltage to the power window motor through the power window motor up circuit. Since the opposite side of the motor is connected to the normally closed contacts of the down relay to ground through the power window motor down circuit, the window moves up.

The rear passenger power windows can also be controlled from the power window master switch. The power window master switches for the rear passenger power windows have two positions UP and Down and its position is a direct input into the DDM. Upon receiving a request for rear passenger power window operation (switch activation), the DDM transmits a Class 2 message indicating the changed switch position. When the BCM receives this message, the BCM can control the rear window up and down relays.

Express Down Operation

The express down function controls both the driver and front passenger power windows but only from the driver door power window master switch. When either the driver or front passenger window switch is momentarily depressed to the express down position, it is a direct input into the DDM. If the request was for the driver power window, the DDM supplies voltage to the power window down circuit continuously until the power window reaches the bottom of its travel. At this point, the DDM senses an over current situation on the power window down circuit and interrupts the voltage supply. If the request was for the front passenger power window, the DDM transmits a Class 2 message indicating an express down function was requested. When the PDM receives this message, the PDM supplies voltage to the power window down circuit continuously until the power window reaches the bottom of its travel. At this point, the PDM senses an over current situation on the power window down circuit and interrupts the voltage supply.

Power Window Lockout Operation

The DDM contains a window lockout switch that is responsible for the disabling of all the passenger windows from the individual passenger window switches. When the window lockout switch is activated, the DDM transmits a Class 2 message indicating that a window lockout request has been received. When the PDM receives this message, it will disable the power window motor up and down circuits. When the BCM receives this message, it will interrupt the up and down relay coil feed voltage for both rear doors. Once activated, the lockout feature will remain in effect until the ignition switch is cycled or the DDM receives another power window lockout switch activation.

POWER DOOR LOCKS DESCRIPTION AND OPERATION

Door Lock System Components

The power door lock system consists of the following components:

- The driver door module (DDM)
- The passenger door module (PDM)
- The body control module (BCM)
- The driver information center (DIC)

- The rear door lock switch
- The door lock relay
- The door unlock relay
- The liftgate lock relay-utility vehicles with liftgate only
- The reversible door lock actuators in each of the doors and liftgate
- LOCKS 20A fuse (rear lock/unlock relay supply voltage)
- ECC 10A fuse (liftgate lock relay supply voltage)

Door Lock System Controls

The power door lock system can be controlled by any of the following:

- A power door lock or unlock switch activation
- A keyless entry transmission
- An automatic door lock function
- A delay lock function
- Door lock cylinder switch activation
- Lockout Prevention
- An airbag deployment

Driver, Passenger and Cargo Door Lock System Operation

The front power door lock switches are integral components of the driver door module (DDM) and passenger door module (PDM). The switches are two position normally open rocker switches. When placed in either the lock or unlock positions, the switches provide a direct input to the DDM or PDM. The DDM or PDM monitors these inputs and sends a Class 2 message indicating a change in the switch's respective position. Modules which activate the power door lock motors receive the Class 2 message and activate the motor in the appropriate direction to lock or unlock the vehicle's doors and liftgate. The rear door lock switch provides a lock and unlock signal to the body control module (BCM). The BCM upon receipt of a lock or unlock signal will control the rear door lock relays and also send a Class 2 message to the DDM and PDM to perform the appropriate function.

The modules which activate the power lock motors are:

- The DDM (driver door lock actuator).
- The PDM (passenger front door lock actuator).
- The BCM (both rear door lock actuators and cargo door/liftgate).

The DDM and PDM are directly connected to the respective door lock actuator through the door lock motor lock and unlock circuits. Once a door lock or unlock request has been received, the module will supply battery voltage to one side of the actuator and ground the other causing the doors to lock or unlock.

The rear passenger and cargo doors differ slightly in that they use lock and unlock relays. The relays supply and coil sides receive a constant voltage through the battery voltage supply circuit. The normally closed contacts are

connected to ground and the control side is connected to the BCM. Once a door lock or unlock request has been received by the BCM, the BCM will ground the control side of the appropriate relay. This energizes the relay and allows voltage to be applied to either the door lock motor lock or unlock circuits. Since the other side of the door lock actuator is connected to the normally closed contacts of the opposing relay to ground, the doors lock or unlock.

Liftgate Locking Operation

The liftgate will lock any time the vehicle is shifted out of park on vehicles equipped with an automatic transmission and at vehicle speeds exceeding 5 kph with manual transmission. This happens in conjunction with auto door locks if enabled or independently of auto door locks if the feature is disabled. This ensures that the liftgate is locked anytime the vehicle is shifted out of park or when the vehicle is in motion.

The liftgate lock relay supply and coil sides receive a constant voltage through the battery voltage supply circuit and the ECC fuse. The normally closed contact is connected to ground and the control side is connected to the body control module (BCM). A lock function will occur when a door lock switch activation, keyless entry lock transmission, auto door lock function or a liftgate lock function has been received by the BCM. The BCM will then ground the control side of the liftgate lock relay. This energizes the relay and allows voltage to be applied to the liftgate lock actuator lock control circuit. Since the other side of the liftgate lock actuator is connected to the normally closed contacts of the door unlock relay to ground, the liftgate will lock. When an unlock function occurs the BCM will ground the control side of the unlock relay and the rear doors and liftgate will unlock.

The BCM also runs diagnostics on the liftgate lock relay control circuit and will set DTC B3825 as current and also send a Class 2 message to the DIC. The DIC will display REPLACE LIFTGATE FUSE to inform the driver that a fault has been detected in the liftgate lock circuit and that the liftgate is not locked. Faults that will set the DTC and cause the DIC to display the message could be any of the following:

- An open ECC fuse
- An open or short to ground in the liftgate lock relay battery positive voltage circuit
- A faulty liftgate lock relay
- An open or short to ground in the liftgate lock relay control circuit
- A short to ground in the liftgate lock actuator lock control circuit
- A faulty BCM

Programmable Automatic Door Locks

The automatic door lock feature can be programmed to control the door lock system. The automatic door lock feature is factory programmed to have all doors lock and unlock. For detailed instructions on programming the automatic door locks, refer to **Vehicle Personalization** in Personalization.

When the automatic door lock feature is programmed to control the door lock system, the driver door module (DDM), passenger door module (PDM) and body control module (BCM) will lock the vehicle doors if the following inputs are true:

- Ignition 1 input is active.
- All door jamb switch inputs are inactive.

- Cargo door or liftgate/liftglass ajar inputs are inactive.
- Transmission is shifted out of park.

This automatic door lock function will only occur once per ignition cycle unless, a door jamb switch input changes state to active and back to inactive. Then the DDM, PDM and BCM will lock all doors again.

Once the automatic door lock feature has locked the doors, the BCM will then unlock all the doors when the transmission is shifted into park.

Lockout Prevention

This feature prevents the locking of the driver door if the ignition key is left in the ignition lock cylinder. If a lock function occurs from any door lock switch and the body control module (BCM) senses an active state on either the left front door latch signal, secondary door latch switch signal and/or the liftgate ajar switch signal circuits and the key in ignition switch signal circuit is in the YES state, the BCM, driver door module (DDM) and passenger door module (PDM) will lock the doors and then the DDM will unlock the driver door.

Delayed Locking Operation

With any door open and a door lock switch is activated in the lock position, the driver door module (DDM), passenger door module (PDM) and the body control module (BCM) will go into a lock pending state. The BCM will also give three audible chimes. When the door is closed, the DDM, PDM and the BCM will lock the doors after approximately five seconds. This feature can be overridden by activating the door lock switch a second time and the doors will lock even with a door open.

Unlock After Air Bag Deployment

This feature will unlock all of the vehicle doors 15 seconds after an air bag deployment.

DOOR AJAR INDICATOR DESCRIPTION AND OPERATION

Door Ajar Indicator System Components

The door ajar indicator system consists of the following components:

- The driver door module (DDM)
- The passenger front door module (PDM)
- The body control module (BCM)
- The instrument panel cluster (IPC)
- The driver information center (DIC)
- The driver door ajar switch
- The passenger door ajar switch
- The left rear door ajar switch
- The right rear door ajar switch

- The liftgate ajar switch

Driver Door Ajar And Passenger Door Ajar

The DDM and PDM receive a discrete input from the respective door ajar switch to indicate the status of the door. The DDM or PDM then communicates this status to the IPC via class 2 message. The IPC, upon receipt of this class 2 message, will illuminate the appropriate door ajar message in the DIC and also send a class 2 message to the radio to activate the door ajar audible warning when the following conditions are met:

- The transmission is removed from PARK
- The vehicle speed is greater than 8.05 km/h (5 mph)

Left Rear Door Ajar And Right Rear Door Ajar

The BCM receives a discrete inputs from both the left and right rear door and liftgate ajar switches to indicate the status of the doors and liftgate. The BCM then communicates this status to the IPC via class 2 message. The IPC, upon receipt of this class 2 message, will illuminate the appropriate door ajar message in the DIC and also send a class 2 message to the radio to activate the door ajar audible warning when the following conditions are met:

- The transmission is removed from PARK
- The vehicle speed is greater than 8.05 km/h (5 mph)

OUTSIDE MIRROR DESCRIPTION AND OPERATION (POWER MIRRORS)

Power Mirror System

Power Mirror System Components

The power mirror system consists of the following components:

- The driver door module - Class 2 module with integrated switches and requires programming when replaced
- The passenger door module - Class 2 module with integrated switches, requires programming when replaced and also contains the RFA receiver
- The power mirror direction switch - Integrated into DDM and is a 4 position momentary switch that provides a signal input to the DDM for up, down, left/extend and right/retract with a mirror switch activation
- The mirror select switch - Integrated into DDM and is a 3 position switch that allows the operator to select the left or right mirror and also a neutral/fold position
- The left outside power mirror - Contains both the vertical and horizontal mirror motors and is serviced as a complete mirror assembly
- The right outside power mirror - Contains both the vertical and horizontal mirror motors and is serviced as a complete mirror assembly
- The body control module - Class 2 module that requires programming when replaced, serves as the power

mode master and is the main message handler

- The DDM 10A fuse - Located in the I/P fuse block and is hot at all times
- The PDM 10A fuse - Located in the I/P fuse block and is hot at all times
- The memory switch, if equipped with memory mirrors - Supplied power by the DDM and provides a voltage signal to the DDM upon a switch activation
- The horizontal and vertical position sensors, if equipped with memory mirrors - Supplied a 5 volt and low reference by the DDM/PDM and provide a variable voltage signal to the DDM/PDM that is proportional to mirror position
- The park neutral position switch, if equipped with memory mirrors - Provides transmission gear selection information to the PCM and is used for memory recall and mirror tilt in reverse functions
- The powertrain control module, if equipped with memory mirrors - Class 2 module that requires programming when replaced and provides Class 2 message indicating transmission gear selection
- The driver Information Center (DIC), if equipped with memory mirrors - Part of the instrument cluster which is a Class 2 module that requires programming when replaced and is used to personalize the memory recall and mirror tilt in reverse functions
- Fold motor in each of the outside mirrors, if equipped with power fold mirrors - Provides extend and retract movements of the mirror and is serviced as a complete mirror assembly

Each of the outside power mirrors contains 2 reversible motors to provide horizontal and vertical movement of the mirror glass. The vertical motor operates the up and down directions and the horizontal motor operates the left and right directions. If equipped with power folding mirrors, each outside power mirror will contain a reversible fold motor to operate the extend and retract functions. Each of the mirror motors are circuit breaker protected.

Power Mirror System Controls

The power mirror switch incorporates a 3 position mirror select switch and a 4 position mirror direction switch. The mirror select switch allows the operator to select the mirror to be moved by selecting the L position for the left power mirror, selecting the R position for the right power mirror or the center which is the neutral/fold position. The mirror direction switch is a 4 position switch that allows the operator to move the selected mirror up, down, left or right. The mirror direction switch also functions as the folding mirror switch. When the selector switch is in the neutral/fold position, activate the mirror direction switch to the left to extend the mirrors and right to retract the mirrors.

Power Mirror System Operation

The power mirror switch is integrated into the DDM. The left and right mirror positions of the select switch and 4 positions of the direction switch, when active, will provide a signal to the DDM. If the selector switch is placed in the L position and the up switch is depressed, 2 signals will be supplied to the DDM. The DDM upon receipt of these signals will provide battery voltage to the mirror motor left/up control circuit and ground to the mirror motor down control circuit and the mirror will move up. The remainder of the driver mirror functions operate in the same manner as described above except the DDM will supply battery voltage and ground to the appropriate control circuits for the direction selected. If the passenger mirror is selected and a direction switch is activated, the DDM sends a class 2 message to the PDM indicating that the passenger mirror was selected and the direction to be commanded. The PDM will then supply battery voltage and ground to the appropriate control

circuits for the direction selected.

Memory Mirror System

Memory Mirror System Controls

or

The DDM and PDM are capable of storing mirror positions and controlling the mirrors to these positions to the preferred settings of 2 different drivers. Each driver will be able to personalize the memory system by positioning the mirrors and seats to their preferred settings. Then press and hold the memory 1 or memory 2 button until an audible chime is heard and the current mirror positions will be stored into memory of the DDM and PDM. Seat position will be stored in the Driver Seat Module (DSM). Once the mirror and seat positions have been stored into memory, a momentary memory 1 or memory 2 switch activation will supply the DDM a battery voltage signal. The DDM, upon receipt of the memory switch signal, with the transmission in park or neutral, will then drive the driver mirror to the corresponding stored memory position. The DDM will also send a class 2 message to the PDM and DSM indicating that a memory switch activation occurred. The PDM will then drive the passenger mirror and the DSM will drive the driver seat to the corresponding stored memory position. The memory system can also be controlled by any of the following if programmed using the Driver Information Center (DIC) to enable/disable the features:

- Auto exit/entry seat positioning
- Mirror and seat position recall on a keyless entry unlock activation
- Mirror and seat position recall on ignition key insertion
- Mirror tilt in reverse

For further information on programming and configuration, refer to Driver Personalization in Personalization.

Memory Mirror System Operation

Mirror position is determined by both horizontal and vertical position sensors in each of the power mirrors. The DDM and PDM supplies a reference voltage and a low reference to these sensors and determines mirror position through the horizontal and vertical position signal circuits.

The memory switch receives power from the DDM through the battery supply voltage circuit and the DDM fuse. The DDM upon receipt of a memory switch signal input or an appropriate class 2 message from the BCM, the DDM and PDM will then supply battery voltage and ground to the appropriate power mirror motors through the mirror motor control circuits to move the mirrors to the predetermined positions.

Mirror Tilt in Reverse Controls

This feature is capable of tilting the left, right or both power mirrors when the transmission is placed in reverse to provide enhanced visibility during parking or backing maneuvers and is programmable through the Driver Information Center. This feature can be personalized to the needs of 2 different drivers. For further information, refer to Driver Personalization in Personalization.

Mirror Tilt in Reverse Operation

When the vehicle is placed in reverse and the appropriate class 2 message from the BCM is received by the DDM and PDM, the DDM and PDM will then supply battery voltage and ground to the appropriate power mirror motors through the mirror motor control circuits to move the mirrors to the predetermined positions. The positions that are stored can be altered by starting the engine, applying the brake, placing the vehicle in reverse and controlling both the left and right mirrors the desired positions and shifting the vehicle out of reverse. These new positions will be stored for the last memory recall that happened.

Folding Mirror System

Folding Mirror System Controls

The folding mirror system requires signals from 2 separate switches. The mirror select switch must be in the neutral/fold position and the mirror direction switch must be activated to the left/extend or right/retract positions. Both switches are integrated into the DDM and provide direct signals.

Folding Mirror System Operation

Upon receipt of the required switch inputs the DDM will supply battery voltage and ground to the mirror fold motor control circuits to perform the requested extend or retract function. The DDM will also send a class 2 message to the PDM indicating the requested function. The PDM will supply battery voltage and ground to the mirror fold motor control circuits to perform the requested extend or retract function.

OUTSIDE MIRROR DESCRIPTION AND OPERATION (HEATED MIRRORS)

Heated OSRV Mirror

On vehicles equipped with heated OSRV mirrors, the DDM and PDM controls the activation of the mirror heaters. Upon receiving a Class 2 message indicating a request for heated mirrors, the DDM, and PDM for the passenger side, will activate the mirror heater output. The mirror heaters will remain active until a new message is received indicating rear defogger is to be deactivated, either by driver input or by expiration of a calibrated timer.

OUTSIDE MIRROR DESCRIPTION AND OPERATION (AUTO DAY - NIGHT MIRRORS)

Mirrors - Outside Automatic Day/Night Feature

The automatic day/night feature of the driver outside rearview mirror is controlled by the inside rearview mirror. The inside rearview mirror supplies a signal and a low reference to the driver outside rearview mirror. The voltage on the signal circuit of the driver outside rearview mirror varies between 0.5 to 1.5 volts depending on light conditions present at the inside rearview mirror. At night, with the automatic day-night feature enabled, the driver outside rearview mirror will automatically darken with the inside rearview mirror to reduce the glare from the headlamps from behind. The voltage on the signal circuit of the driver outside rearview mirror will be near 1.5 volts. In the daytime, the mirrors are in a normal state. The voltage on the signal circuit of the driver outside rearview mirror may be less than or near 0.5 volts. Refer to **Automatic Day-Night Mirror Description and Operation** in Stationary Windows for further description and operation of the inside rearview mirror.

SPECIAL TOOLS AND EQUIPMENT

SPECIAL TOOLS

Special Tools

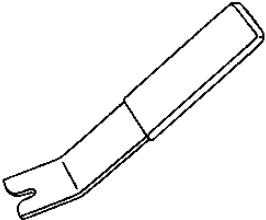
Illustration	Tool Number/Description
	<p data-bbox="906 348 1289 413">J 38778 Door Trim Pad Clip Remover</p>