

Step 14

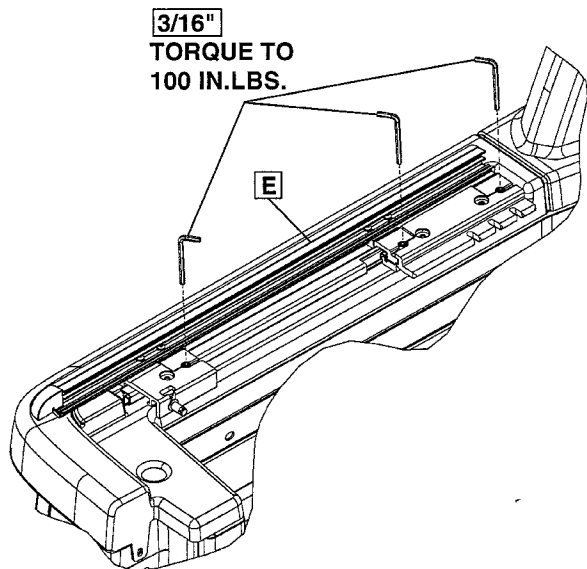

Step 2A

Repeat these steps on left hand side rail (Item E - not shown).

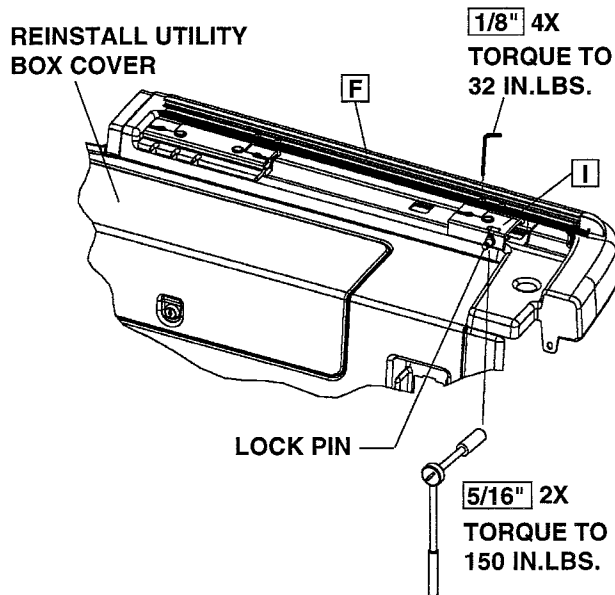

Slam Latch Adjustment

Step 1

Slightly loosen #10 hex nuts about 1-1/2 turns. Be careful not to over loosen or retightening may become difficult. Slide slam latch in to align with lock pins (on items I and J). This step requires opening and closing of cover to achieve proper alignment. Repeat this step for right hand side adjustment.

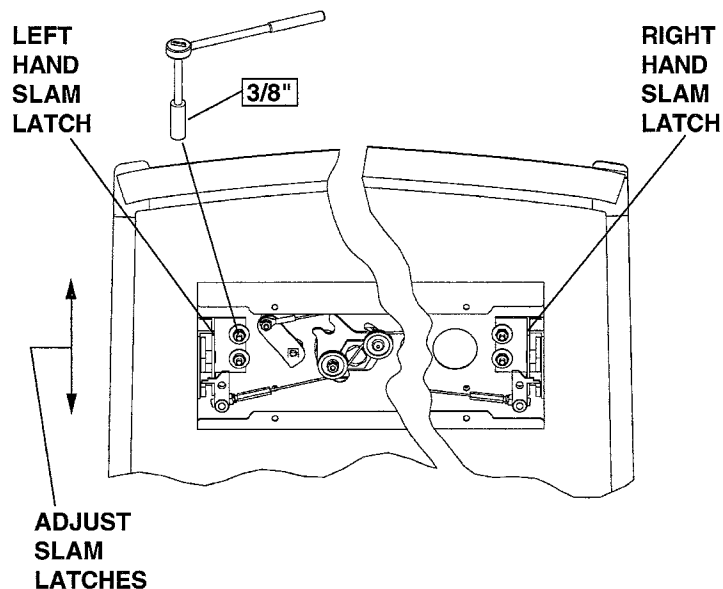

Step 2B

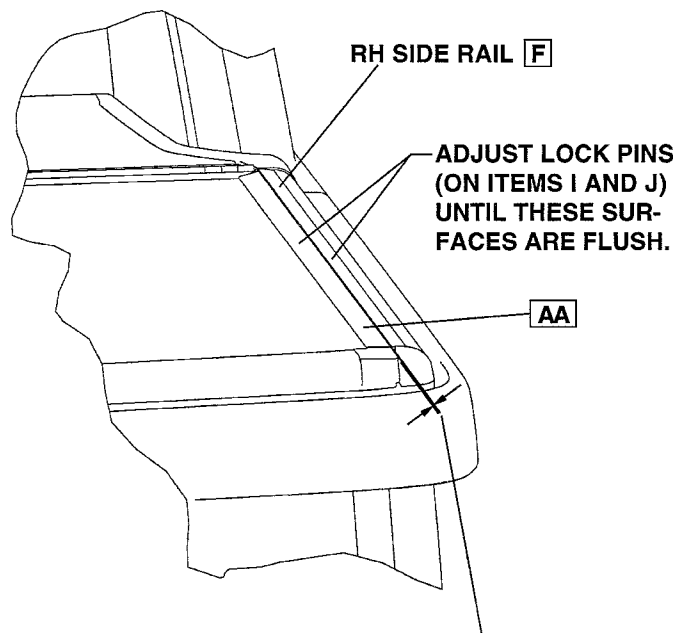

SLIDE SIDE RAILS (ITEMS E AND F) UP TO EDGE OF COVER (ITEM AA) UNTIL A ZERO GAP IS ACHIEVED. HOLD RAIL SEAL (ITEMS E AND F) IN PLACE WHILE OPENING COVER. TORQUE FASTENERS AS SHOWN IN STEP 2A

Tonneau Cover

IR 190C05

PART NO. 88965272

SHEET 5 OF 18

ALL INFORMATION WITHIN ABOVE BORDER TO BE PRINTED EXACTLY AS SHOWN ON 8.5 x 11 WHITE 16 POUND NON-BOND RECYCLABLE PAPER. PRINT ON BOTH SIDES, EXCLUDING TEMPLATES. TO BE UNITIZED IN ACCORDANCE WITH GM SPS SPECIFICATIONS.

DATE	REVISION	AUTH	DR

TITLE
INSTALLATION INSTRUCTIONS
Tonneau Cover
PART NO. 88965272
SHEET 5 OF 18