

**Installation Instructions**

**Step 1**

**INSTALL CLAMP (ITEM C) TO BE FLUSH WITH END OF CHANNEL**

**SLIDE RAIL CLAMPS (ITEMS C AND D) ONTO RAIL AT INDICATED SLOT STARTING WITH CLAMPS (ITEM C) MARKED "X"**

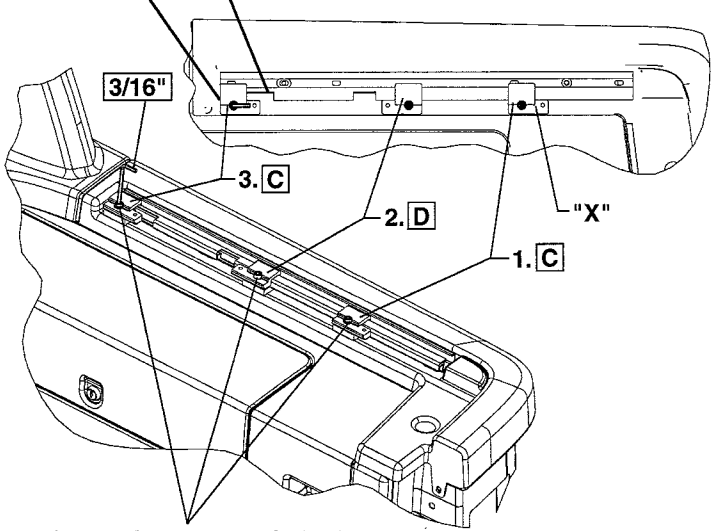

**FINGER TIGHTEN INDICATED ITEMS AT THIS TIME.**

**Step 2**

**SLIDE RAIL CLAMPS (ITEMS C AND D) ONTO RAIL AT INDICATED SLOT, STARTING WITH CLAMP (ITEM D) MARKED "X"**

**INSTALL CLAMP (ITEM D) TO BE FLUSH WITH END OF CHANNEL**

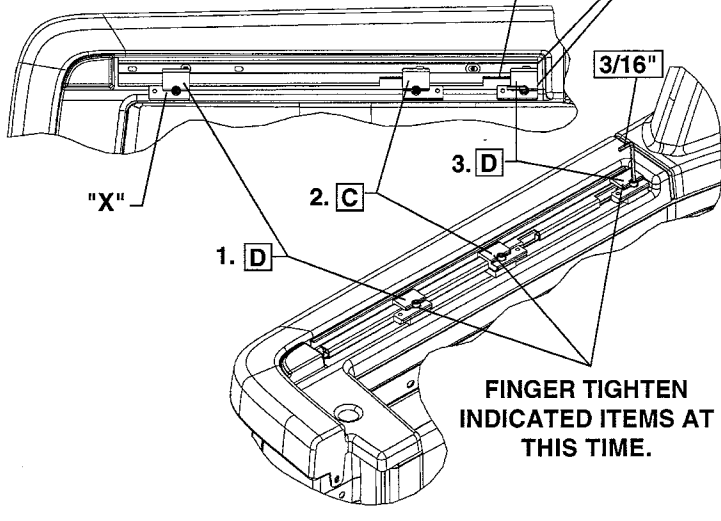

**FINGER TIGHTEN INDICATED ITEMS AT THIS TIME.**

**Step 3**

Place items H and J onto right hand rail as shown. Place items G and I onto left hand rail as shown.

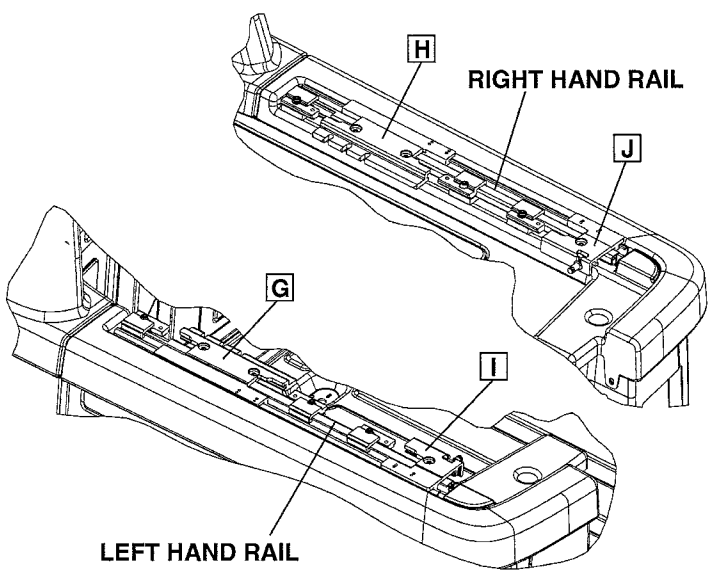

**Step 4**

Insert seal (Item S) into expansion joint on truck rail cap as shown. Align ends with bottom of rail cap where joint starts. Place items H and J onto right hand rail as shown. Place items G and I onto left hand rail as shown.

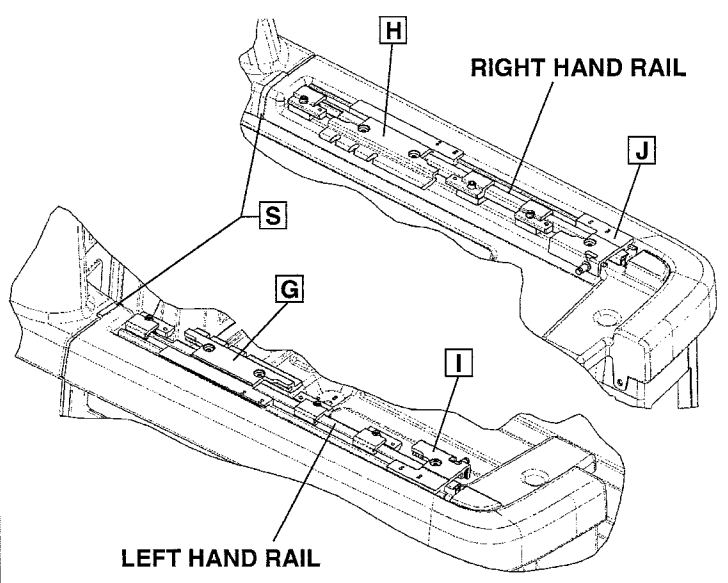

**Tonneau Cover**

**IR 190C05**

**PART NO. 88965272**

**SHEET 2 OF 18**

ALL INFORMATION WITHIN ABOVE BORDER TO BE PRINTED EXACTLY AS SHOWN ON 8.5 x 11 WHITE 16 POUND NON-BOND RECYCLABLE PAPER. PRINT ON BOTH SIDES, EXCLUDING TEMPLATES. TO BE UNITIZED IN ACCORDANCE WITH GM SP SPECIFICATIONS.

DATE	REVISION	AUTH	DR

<b>TITILE</b>		<b>INSTALLATION INSTRUCTIONS</b>	
		<b>Tonneau Cover</b>	
<b>PART NO.</b>	<b>88965272</b>	<b>SHEET</b>	<b>2 OF 18</b>