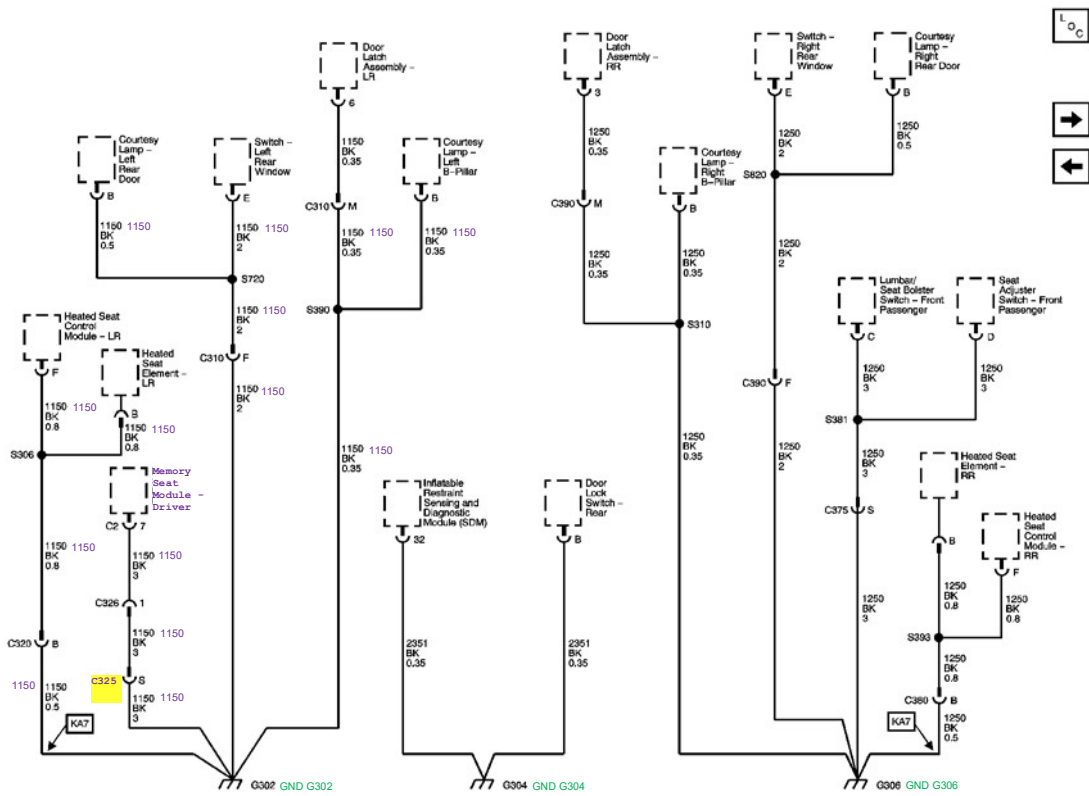

**Fig. 42: STUD 1, STUD 2, VSES/ECAS, BLOWER, ABS, and MBEC 1 Fuses, RT DOORS and SEATS Circuit Breakers Schematic**  
 Courtesy of GENERAL MOTORS CORP.



**Fig. 62: G302, G304, and G306 Schematic**  
 Courtesy of GENERAL MOTORS CORP.